

**RELIABLE.
POWERFUL.
ENVIRONMENT-FRIENDLY.**



ISO 9001 Certification
(TCM Shiga plant)

ISO 14001 Certification
(TCM Shiga plant)

- TCM retains the right to change these products and specifications without incurring any obligation relating to such changes.
- These products and specifications are subject to change without notice.
- Photos and illustrations may or may not include optional equipment and accessories.
- Features and specifications may vary depending on markets.

Manufactured by
TCM
TCM CORPORATION

1-15-5 Nishi-Shimbashi, Minato-ku,
Tokyo 105-0003 Japan
TEL:+81-3-3591-8176
FAX:+81-3-3591-8152
<http://www.tcmglobal.net>

Distributed by

**3.5-5t | DIESEL POWERED
8000-11000lbs. | PNEUMATIC TIRE TRUCKS**

FD35T2	3500kg/600mm 8000lbs/24in	FD40T2	4000kg/600mm 9000lbs/24in	FD45T2	4500kg/600mm 10000lbs/24in	FD50T2	5000kg/600mm 11000lbs/24in
---------------	------------------------------	---------------	------------------------------	---------------	-------------------------------	---------------	-------------------------------

STANDARD SPECIFICATIONS

1	Manufacturer		TCM					
	Model		FD35T2	FD40T2	FD45T2	FD50T2		
3	Load Capacity	Load Center 500mm	kg	4000	4500	5000	5000	
		Load Center 600mm (24in)	kg (lbs)	3500 (8000)	4000 (9000)	4500 (10000)	5000 (11000)	
5	Power Type	Diesel						
6	Operator Position	Sit Down Rider Type						
7	Tire Type	Front / Rear	Pneumatic					
8	Wheels (X=driven)	Front / Rear	2 X / 2					
9	Maximum Fork Height		mm (in)	3000 (118.1)	3000 (118.1)	3000 (118.1)	3000 (118.1)	
10	Free Lift		mm (in)	150 (5.9)	150 (5.9)	155 (6.1)	160 (6.3)	
13	Fork Size	L X W X T	mm (in)	1070 X 150 X 50 (42.1 X 5.9 X 2.0)	1070 X 150 X 50 (42.1 X 5.9 X 2.0)	1070 X 150 X 50 (42.1 X 5.9 X 2.0)	1220 X 150 X 60 (48.0 X 5.9 X 2.4)	
	Fork Spread (Outside)	Max. / Min.	mm (in)	1290 (50.8) / 300 (11.8)	1290 (50.8) / 300 (11.8)	1290 (50.8) / 300 (11.8)	1290 (50.8) / 300 (11.8)	
14	Tilt Angle	Fwd / Bwd	deg	6 / 12	6 / 12	6 / 12	6 / 12	
15	Length to Fork Face		mm (in)	3080 (121.3)	3110 (122.4)	3190 (125.6)	3390 (133.5)	
16	Overall Width		mm (in)	1480 (58.3)	1480 (58.3)	1480 (58.3)	1480 (58.3)	
17	Mast Height Fork Lowered		mm (in)	2230 (87.8)	2230 (87.8)	2235 (88.0)	2360 (92.9)	
18	Mast Height Fork Raised		mm (in)	4265 (167.9)	4265 (167.9)	4265 (167.9)	4420 (174.0)	
19	Overhead Guard Height		mm (in)	2250 (88.6)	2250 (88.6)	2250 (88.6)	2250 (88.6)	
21	Turning Radius (Outside)		mm (in)	2790 (109.8)	2815 (110.8)	2860 (112.6)	3035 (119.5)	
22	Load Distance (Centerline of Front Axle to Front Face of Forks)		mm (in)	560 (22.0)	560 (22.0)	590 (23.2)	590 (23.2)	
	Rear Overhang		mm (in)	520 (20.5)	550 (21.7)	600 (23.6)	600 (23.6)	
23	Basic Right Angle Stacking Aisle Width			5440 (214.2)	5460 (215.0)	5490 (216.1)	5810 (228.7)	
24	Speeds	Travel Max.	No Load Fwd / Rvs	km/h (mph)	26.0 (16.1) / 20.0 (12.4)	26.0 (16.1) / 20.0 (12.4)	26.0 (16.1) / 20.0 (12.4)	26.0 (16.1) / 20.0 (12.4)
		Lifting	Full Load	mm/s (fpm)	570 (112.2)	570 (112.2)	530 (104.4)	500 (98.5)
		Lowering	No Load	mm/s (fpm)	590 (116.2)	590 (116.2)	550 (108.3)	550 (108.3)
			Full Load	mm/s (fpm)	500 (98.5)	500 (98.5)	450 (88.6)	450 (88.6)
26		No Load	mm/s (fpm)	550 (108.3)	550 (108.3)	500 (98.5)	500 (98.5)	
28	Max. Drawbar Pull	Full / No Load	kN(lbs)	34.3 / 17.2 (7720 / 3860)	34.3 / 17.2 (7720 / 3860)	34.3 / 17.7 (7720 / 3970)	34.3 / 18.6 (7720 / 4190)	
29	Max. Gradeability*	Full Load	%	29	25	22	20	
		No Load	%	20	20	20	20	
32	Total Weight		kg (lbs)	6090 (13430)	6440 (14200)	6980 (15390)	7280 (16050)	
33	Weight Distribution	Full Load	Load Center 600mm (24in)	kg (lbs)	8390 (18950)	9210 (20390)	10140 (22480)	10990 (24190)
			Rear	kg (lbs)	1200 (2480)	1320 (2810)	1340 (2910)	1290 (2860)
		No Load	Front	kg (lbs)	2860 (6310)	2800 (6170)	2960 (6530)	3280 (7230)
			Rear	kg (lbs)	3230 (7120)	3640(8030)	4020 (8860)	4000 (8820)
35	Tires	Number	Front / Rear	2 / 2				
37	Size	Front	3.00-15-18PR (I)					
		Rear	7.00-12-12PR (I)					
38	Wheelbase		mm (in)	2000 (78.7)	2000 (78.7)	2000 (78.7)	2200 (86.6)	
39	Tread	Front	mm (in)	1180 (46.5)	1180 (46.5)	1180 (46.5)	1180 (46.5)	
		Rear	mm (in)	1195 (47.0)	1195 (47.0)	1195 (47.0)	1195 (47.0)	
	Backrest Height		mm (in)	1220 (48.0)	1220 (48.0)	1220 (48.0)	1370 (53.9)	
	Overhead Guard Clearance		mm (in)	1020 (40.2)	1020 (40.2)	1020 (40.2)	1020 (40.2)	
	Counterweight Height		mm (in)	1320 (52.0)	1320 (52.0)	1320 (52.0)	1320 (52.0)	
	Drawbar Pin Center Height		mm (in)	320 (12.6)	320 (12.6)	320 (12.6)	320 (12.6)	
	Floor Height		mm (in)	845 (33.3)	845 (33.3)	845 (33.3)	845 (33.3)	
40	Underclearance	Min Full Load	mm (in)	155 (6.1)	155 (6.1)	155 (6.1)	155 (6.1)	
		Center of wheelbase	mm (in)	185 (7.3)	185 (7.3)	185 (7.3)	185 (7.3)	
42	Brake	Service (Foot)		Hydraulic - Foot pedal	Hydraulic - Foot pedal	Hydraulic - Foot pedal	Hydraulic - Foot pedal	
		Parking		Mechanical - Hand lever	Mechanical - Hand lever	Mechanical - Hand lever	Mechanical - Hand lever	
45	Battery	Voltage / Capacity (5HR)	V/AH	2x 12 / 60				
49	Internal Combustion Engine	Make - Model		MITSUBISHI S6S - T				
		Rated Output / r.p.m.	Hp/rpm	91 / 2300 SAE GROSS				
			kW/rpm	64 / 2300				
			PS/rpm	87 / 2300				
			lb-ft/rpm	216.1 / 1700				
			Max. Torque / r.p.m.	N · m/rpm	293 / 1700			
		kgf · m/rpm	29.9 / 1700					
52	Transmission	Number of Cylinders		6				
		Displacement	lit (cu-in)	4.996 (304.9)				
		Fuel Tank Capacity	lit (US gal.)	115 (30.5)				
55	Transmission	Type		Automatic Power Shift				
		Stage Fwd. - Rvs		2 - 1				
57	Operating Pressure	For Attachment	kg/cm ² (psi)	180 (2560)				

NOTE : * Computed Values & subject to load condition

LOAD CHART

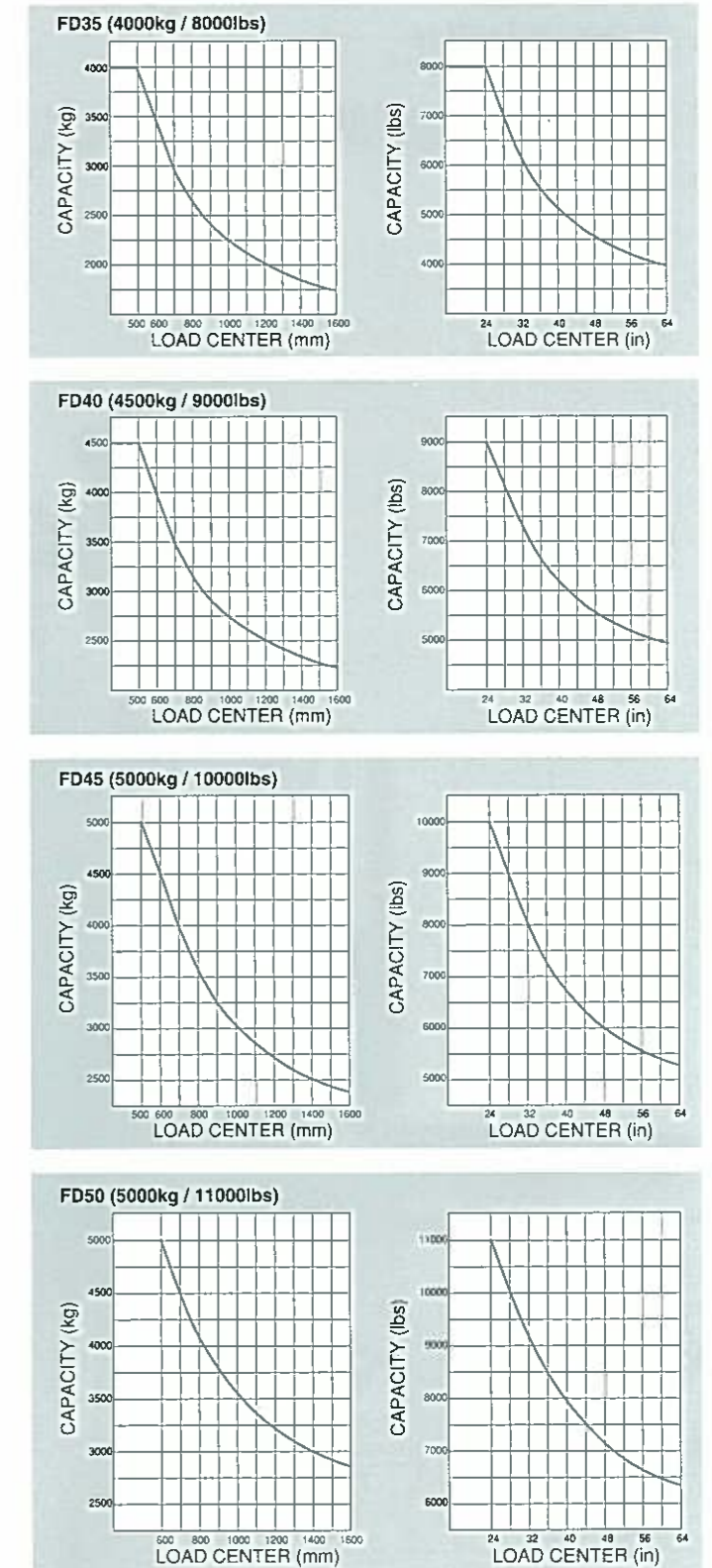

NOTE : Capacity shown is computed with upright in vertical position. Load center are determined front face of forks. Capacities are based on a 1000mm or 48in cube load configuration with the center of gravity (C.G.) at the true center of the cube, and standard forks. Truck capacities with upright in forward tilt position will be less. Long forks, and unusually wide or tall loads may also reduce capacity. Contact TCM representative for capacity information on irregular loads. Specific capacities are shown on truck nameplates. TCM Industrial Trucks are equipped with certain safety devices as standard equipment. TCM will not assume any liability for injuries or damage arising from or caused by the removal of any safety devices from any of its products.

STANDARD SPECIFICATIONS

Wide View Mast VM

Mast Model	Rated Capacity												Max. Fork Height	Overall Mast Height										Tilting Angle F/B	Service Weight								
	FD35T2			FD40T2			FD45T2			FD50T2				Lowered					Raised with Backrest						FD35T2		FD40T2		FD45T2		FD50T2		
	Load Center			Load Center			Load Center			Load Center				FD35T2		FD45T2		FD50T2		FD35T2		FD40T2			FD45T2		FD50T2						
	500mm	600mm	24in	500mm	600mm	24in	500mm	600mm	24in	500mm	600mm	24in		mm	in	mm	in	mm	in	mm	in	mm	in		mm	in	mm	in	mm	in			
VM250	4000	3500	8000	4500	4000	9000	5000	4500	10000	5000	5000	11000	2500	98.4	1980	78.0	1985	78.1	2110	83.1	3765	148.2	3920	154.3	6/10	6030	13300	6380	14070	6910	15240	7210	15900
VM300	4000	3500	8000	4500	4000	9000	5000	4500	10000	5000	5000	11000	3000	118.1	2230	87.8	2235	88.0	2360	92.9	4265	167.9	4420	174.0	6/12	6090	13430	6440	14200	6980	15390	7280	16050
VM330	4000	3500	8000	4500	4000	9000	5000	4500	10000	5000	5000	11000	3300	130.0	2380	93.7	2385	93.9	2510	98.8	4565	179.7	4720	185.8	6/12	6120	13500	6470	14270	7020	15480	7320	16140
VM350	4000	3500	8000	4500	4000	9000	5000	4500	10000	5000	5000	11000	3500	137.8	2480	97.6	2485	97.8	2610	102.8	4765	187.6	4920	193.7	6/12	6140	13540	6490	14310	7040	15520	7340	16180
VM375	4000	3500	8000	4500	4000	9000	5000	4500	10000	5000	5000	11000	3750	147.6	2605	102.6	2610	102.8	2735	107.7	5015	197.4	5170	203.5	6/6 *6/12	6210	13690	6560	14460	7080	15610	7380	16270
VM400	4000	3500	8000	4500	4000	9000	5000	4500	10000	5000	5000	11000	4000	157.6	2780	109.4	2785	109.6	2910	114.6	5265	207.3	5420	215.7	6/6 *6/12	6260	13800	6610	14580	7180	15830	7480	16490
VM425	4000	3500	8000	4500	4000	9000	5000	4500	10000	5000	5000	11000	4250	167.3	2905	114.4	2910	114.6	3035	119.5	5515	217.1	5670	223.2	6/6 *6/12	6290	13870	6640	14640	7210	15900	7510	16560
VM450	4000	3500	8000	4500	4000	9000	5000	4500	10000	5000	5000	11000	4500	177.2	3030	119.3	3035	119.5	3160	124.4	5765	227.0	5920	233.1	6/6 *6/12	6310	13920	6660	14690	7230	15940	7530	16600
VM475	3500 *4000	3500	8000	4000 *4500	4000	9000	4800	4500	10000	5000	5000	11000	4750	187.0	3155	124.2	3160	124.4	3285	129.3	6015	236.8	6170	242.9	6/6	6370	14050	6720	14820	7270	16030	7570	16690
VM500	3500 *3700	3500	8000	4000 *4300	4000	9000	4500 *4600	4500	10000	5000	5000	11000	5000	196.9	3280	129.1	3285	129.3	3410	134.3	6265	246.7	6420	252.8	6/6	6390	14090	6740	14860	7300	16100	7600	16780
VM550	2800 *3300	2800 *3300	6200 *7300	3200 *3900	3200 *3900	7000 *8600	4000 *4400	4000 *4400	8800 *9700	4000 *4800	4000 *4800	8800 *10600	5500	216.5	3580	140.9	3585	141.1	3710	146.1	6765	266.3	6920	272.4	3/6	6470	14270	6820	15040	7440	16410	7740	17070
VM600	2200 *3200	2200 *3200	4900 *7100	2500 *3700	2500 *3700	5500 *8200	3550 *4000	3550 *4000	7800 *8800	3350 *4000	3350 *4000	7400 *8800	6000	236.2	3830	150.8	3835	151.0	3960	155.9	7265	286.0	7420	292.1	3/6	6520	14380	6870	15150	7500	16540	7800	17200

Wide View Full Free 2-Stage Mast VFM

Mast Model	Rated Capacity												Max. Fork Height	Overall Mast Height										(2) Free lift with Backrest						Tilting Angle F/B	Service Weight								
	FD35T2			FD40T2			FD45T2			FD50T2				Lowered					(1) Raised with Backrest					FD35T2		FD45T2		FD50T2			FD35T2		FD40T2		FD45T2		FD50T2		
	Load Center			Load Center			Load Center			Load Center				FD35T2		FD45T2		FD50T2		FD35T2		FD40T2		FD45T2		FD50T2		FD35T2			FD40T2		FD45T2		FD50T2				
	500mm	600mm	24in	500mm	600mm	24in	500mm	600mm	24in	500mm	600mm	24in		mm	in	mm	in	mm	in	mm	in	mm	in	mm	in	mm	in	mm	in		mm	in	mm	in	mm	in			
VFM250	4000	3500	8000	4500	4000	9000	5000	4500	10000	5000	5000	11000	2500	98.4	1985	78.1	1985	78.1	2110	83.1	3765	148.2	3920	154.3	765	30.1	765	30.1	740	29.1	6/10	6230	13740	6580	14510	6990	15410	7300	16100
VFM300	4000	3500	8000	4500	4000	9000	5000	4500	10000	5000	5000	11000	3000	118.1	2195	86.4	2235	88.0	2360	92.9	4265	167.9	4420	174.0	960	37.8	1015	40.0	990	39.0	6/12	6280	13850	6630	14620	7060	15570	7370	16250
VFM330	4000	3500	8000	4500	4000	9000	5000	4500	10000	5000	5000	11000	3300	130.0	2395	94.3	2385	93.9	2510	98.8	4565	179.7	4720	185.8	1160	45.7	1165	45.9	1140	44.9	6/12	6340	13980	6690	14750	7100	15660	7410	16340
VFM350	4000	3500	8000	4500	4000	9000	5000	4500	10000	5000	5000	11000	3500	137.8	2495	98.2	2485	97.8	2610	102.8	4765	187.6	4920	193.7	1260	49.6	1265	49.8	1240	48.8	6/12	6360	14020	6710	14800	7130	15720	7440	16410
VFM375	4000	3500	8000	4500	4000	9000	5000	4500	10000	5000	5000	11000	3750	147.6	2610	102.8	2610	102.8	2735	107.7	5015	197.4	5170	203.5	1390	54.7	1390	54.7	1365	53.7	6/6 *6/12	6400	14110	6750	14880	7160	15790	7470	16470
VFM425	4000	3500	8000	4500	4000	9000	5000	4500	10000	5000	5000	11000	4250	167.3	2910	114.6	2910	114.6	3035	119.5	5515	217.1	5670	223.2	1690	66.5	1690	66.5	1665	65.6	6/6 *6/12	6560	14460	6910	15240	7320	16140	7600	16780
VFM400	4000	3500	8000	4500	4000	9000	5000	4500	10000	5000	5000	11000	4000	157.6	2795	110.0	2785	109.6	2910	114.6	5265	207.3	5420	215.7	1560	61.4	1565	61.6	1540	60.6	6/6 *6/12	6520	14380	6870	15150	7290	16070	7570	16690
VFM450	4000	3500	8000	4500	4000	9000	5000	4500	10000	5000	5000	11000	4500	177.2	3045	119.9	3035	119.5	3160	124.4	5765	227.0	5920	233.1	1810	71.3	1815	71.5	1790	70.5	6/6 *6/12	6590	14530	6940	15300	7350	16210	7640	16850
VFM475	3500 *4000	3500	8000	4000 *4500	4000	9000	4800	4500	10000	5000	5000	11000	4750	187.0	3160	124.4	3160	124.4	3285	129.3	6015	236.8	6170	242.9	1940	76.4	1940	76.4	1915	75.4	6/6	6620	14600	6970	15370	7390	16290	7670	16910
VFM500	3500 *3700	3500	8000	4000 *4300	4000	9000	4500 *4600	4500	10000	5000	5000	11000	5000	196.9	3285	129.3	3285	129.3	3410	134.3	6265	246.7	6420	252.8	2065	81.3	2065	81.3	2040	80.3	6/6	6660	14690	7010	15460	7420	16360	7710	17000
VFM550	2800 *3300	2800 *3300	6200 *7300	3200 *3900	3200 *3900	7000 *8600	4000 *4400	4000 *4400	8800 *9700	4000 *4800	4000 *4800	8800 *10600	5500	216.5	3585	141.1	3585	141.1	3710	146.1	6765	266.3	6920	272.4	2365	93.1	2365	93.1	2340	92.1	3/6	6790	14970	7140	15740	7550	16650	7840	17290
VFM600	2200 *3200	2200 *3200	4900 *7100	2500 *3700	2500 *3700	5500 *8200	3550 *4000	3550 *4000	7800 *8800	3350 *4000	3350 *4000	7400 *8800	6000	236.2	3835	151.0	3835	151.0	3960	155.9	7265	286.0	7420	292.1	2615	103.0	2615	103.0	2590	102.0	3/6	6850	15100	7200	15880	7620	16800	7910	17440

NOTE : (1) For height without backrest : [FD35T2 · 40T2] - 460mm(-18.1in) [FD45T2] - 385mm(-15.2in) [FD50T2] - 465mm(-18.3in)
 (2) For free lift without backrest : [FD35T2 · 40T2] + 460mm(+18.1in) [FD45T2] + 385mm(+15.2in) [FD50T2] + 465mm(+18.3in) Weight for without backrest : [FD35T2 · 40T2 · 45T2] - 30kg(-67lbs) [FD50T2] - 55kg(-121lbs)

Wide View Full Free 3-Stage Mast VFHM

Mast Model	Rated Capacity												Max. Fork Height	Overall Mast Height										(2) Free lift with Backrest						Tilting Angle F/B	Service Weight							
	FD35T2			FD40T2			FD45T2			FD50T2				Lowered					(1) Raised with Backrest					FD35T2		FD45T2		FD50T2			FD35T2		FD40T2		FD45T2		FD50T2	
	Load Center			Load Center			Load Center			Load Center				FD35T2		FD45T2		FD50T2		FD35T2		FD40T2		FD45T2		FD50T2		FD35T2			FD40T2		FD45T2		FD50T2			
	500mm	600mm	24in	500mm	600mm	24in	500mm	600mm	24in	600mm	24in	mm		in	mm	in	mm	in	mm	in	mm	in	mm	in	mm	in	mm	in	mm		in	mm	in	mm	in			
VFHM360	3900	3500	7700	4400	4000	8800	4900	4500	9900	4800	10500	3600	141.7	1900	74.8	1970	77.6	2050	80.7	4865	191.5	5020	197.6	675	26.6	750	29.5	680	26.8	6/6	6380	14070	6730	14840	7200	15880	7520	16580
VFHM400	3900	3500	7700	4400	4000	8800	4900	4500	9900	4800	10500	4000	157.6	2035	80.1	2105	82.9	2185	86.0	5265	207.3	5420	213.4	810	31.9	885	34.8	815	32.1	6/6	6430	14180	6780	14950	7250	15990	7570	16690
VFHM435	3800	3500	7700	4300	4000	8800	4700	4500	9900	4800	105																											

STANDARD DIMENSIONS

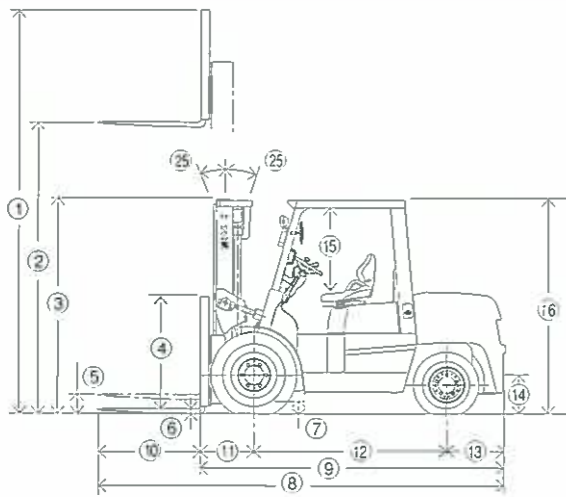

GROUND CLEARANCE	FD35T2 / FD40T2		FD45T2 / FD50T2	
	mm	in	mm	in
Mast	155	6.1	140	5.5
Frame	185	7.3	185	7.3
Front axle	185	7.3	185	7.3
Rear axle	195	7.7	195	7.7
Counter weight	205	8.1	205	8.1

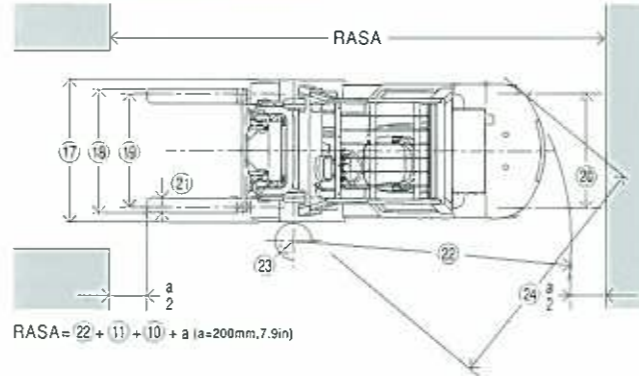

STANDARD DIMENSIONS

Model	FD35T2		FD40T2		FD45T2		FD50T2	
	mm	in	mm	in	mm	in	mm	in
1 Overall height, fork raised (with backrest)	4265	167.9	4265	167.9	4265	167.9	4420	174.0
2 Maximum fork height	3000	118.1	3000	118.1	3000	118.1	3000	118.1
3 Mast height, fork lowered	2230	87.8	2230	87.8	2235	88.0	2360	92.9
4 Backrest height	1220	48.0	1220	48.0	1220	48.0	1370	53.9
5 Free lift	150	5.9	150	5.9	155	6.1	160	6.3
6 Fork thickness	50	2.0	50	2.0	50	2.0	60	2.4
7 Minimum ground clearance	155	6.1	155	6.1	155	6.1	155	6.1
8 Overall length (with forks)	4150	163.4	4180	164.6	4260	167.7	4610	181.5
9 Length to fork face	3080	121.3	3110	122.4	3190	125.6	3390	133.5
10 Fork length	1070	42.1	1070	42.1	1070	42.1	1220	48.0
11 Load distance	560	22.0	560	22.0	590	23.2	590	23.2
12 Wheelbase	2000	78.7	2000	78.7	2000	78.7	2200	86.6
13 Rear overhang	520	20.5	550	21.7	600	23.6	600	23.6
14 Drawbar Pin Center Height	320	12.6	320	12.6	320	12.6	320	12.6
15 Overhead guard clearance (from face of seat)	1020	40.2	1020	40.2	1020	40.2	1020	40.2
16 Overall height (overhead guard)	2250	88.6	2250	88.6	2250	88.6	2250	88.6
17 Overall width	1480	58.3	1480	58.3	1480	58.3	1480	58.3
18 Fork spread (outside)	300~1290	11.8~50.8	300~1290	11.8~50.8	300~1290	11.8~50.8	300~1290	11.8~50.8
19 Tread (front)	1180	46.5	1180	46.5	1180	46.5	1180	46.5
20 Tread (rear)	1195	47.0	1195	47.0	1195	47.0	1195	47.0
21 Fork width	150	5.9	150	5.9	150	5.9	150	5.9
22 Outside turning radius	2790	109.8	2815	110.8	2860	112.6	3035	119.5
23 Inside turning radius	200	7.9	200	7.9	200	7.9	200	7.9
24 Minimum intersecting aisle	2640	103.9	2650	104.3	2670	105.1	2780	109.4
25 Tilt angles (forward-backward)	6° - 12°	6° - 12°	6° - 12°	6° - 12°	6° - 12°	6° - 12°	6° - 12°	6° - 12°

DIMENSIONS WITH FRONT DUAL DRIVE WHEELS (option)

Model	FD35T2		FD40T2		FD45T2		FD50T2	
	mm	in	mm	in	mm	in	mm	in
Tire size (front dual)	7.50-16-8PR		7.50-16-8PR		7.50-16-8PR		7.50-16-8PR	
Service weight	+20kg	+45lbs	+20kg	+45lbs	+20kg	+45lbs	+20kg	+45lbs
17 Overall width	1830	72.0	1830	72.0	1830	72.0	1830	72.0
19 Tread (front)	1340	52.8	1340	52.8	1340	52.8	1340	52.8
22 Outside turning radius	2890	113.8	2950	116.1	2950	116.1	3120	122.8
23 Inside turning radius	200	7.9	200	7.9	200	7.9	200	7.9
24 Minimum intersecting aisle	2800	110.2	2800	110.2	2800	110.2	2950	116.1
Tire size (front dual)	8.25-15-14PR		8.25-15-14PR		-		-	
Service weight	+80kg	+180lbs	+80kg	+180lbs	-		-	
3 Mast height, fork lowered	2245	88.4	2245	88.4	-		-	
17 Overall width	1950	76.8	1950	76.8	-		-	
19 Tread (front)	1435	56.5	1435	56.5	-		-	
22 Outside turning radius	2920	115.0	2950	116.1	-		-	
23 Inside turning radius	200	7.9	200	7.9	-		-	
24 Minimum intersecting aisle	2800	110.2	2850	112.2	-		-	

STANDARD EQUIPMENT AND ACCESSORIES

- [Equipment]**
- Adjustable ORS seat with belt
 - Asbestos-free brake shoe material
 - Automatic shifting T/M
 - Converter oil cooler
 - Donaldson cyclopac aircleaner
 - Drawbar device
 - Durable overhead guard
 - Flow control valve
 - Forks standard length¹⁾
 - Fuel filter & water sedimenter(WTS)
 - Full hydrostatic power steering(OBT)
 - Gas cylinder type bonnet latch
 - High capacity alternator 50A
 - High -visibility wide-view mast(VM300)
 - Hydraulic return filter
 - Lift circuit cut-off valve
 - Load backrest
 - Long-life pneumatic tires
 - Neutral start safety system
 - Power assist brake system
 - Radiator coolant reservoir
 - Transmission oil dipstick
 - Transmission oil return filter
 - Traveling interlock system
 - 2-spool control valve with pressure relief²⁾

[Controls]

- Auto glow system
- Electric T/M shift control lever
- Key switch-engine start/stop
- Lift and tilt levers
- Multi-function switch lever with self-cancelling mechanism(Lighting & turn-signal)
- Parking brake lever with inter-lock
- Tilt adjustable steering post

[Instruments and Switch]

- Battery charging indicator
- Electric horn
- Engine glow indicator
- Engine hourmeter
- Engine oil pressure warning indicator
- Fuel gauge
- Neutral safety indicator
- Water sedimenter indicator
- Water temperature gauge

[Accessories]

- Access-assisted handgrip
- Back-up buzzer
- Back-up light
- Deluxe floor mat
- Front combination lights (turn signal, clearance)
- Head lights - traffic purpose
- Pen holder
- Rear combination lights
- Side view mirrors

1) Std. fork 1070mm(42in.) for 3.5~4.5ton models
Std. fork 1220mm(48in.) for 5ton model.

2) 3-spool valve = Std.: in U.S. production.

- Meets the following major industrial standard and code:
ISO 1074 Counter balanced lift trucks, stability & safety tests
ISO 3691 Powered industrial trucks - safety code
ISO/DIS 3691 Travel & loading interlock
ISO 6292 Powered industrial trucks brake performance and component strength
ISO 6055 Overhead guard
JIS D6001 Powered industrial trucks - safety code
JIS D6011 Industrial trucks, stability & safety tests
JIS D6021 Overhead guard
JIS D6023 Industrial trucks brake performance & safety tests

OPTIONAL EQUIPMENT AND ACCESSORIES

- [Equipment]**
- Airconditioner(SCB AC)
 - Auxiliary hydraulic valve module(3SV-4SV-5SV)
 - Dual airelement(ADE)
 - Fingertip hydraulic levers(FIT)
 - Front windshield with wiper(AW071)
 - Heater(HR)
 - Heater & defroster(SCB DEF)
 - Hydraulic oil cooler(CRH)
 - Large capacity converter oil cooler(CRC)
 - Metalic disk(MDK)
 - Overhead exhaust(TUE)
 - Plate(straight) fin radiator(RADPF)
 - Pneumatic shaped cushion tires(SE)
 - Pre-aircleaner(CAKB)
 - Radiator dust screen(DSR)
 - Right hand direction lever(LCR)
 - Steel cabin(SCB)
 - Steel net roof on overhead guard(HGD)
 - Tilt cylinder boots(TLB)
 - Wide tread(WT)
 - 1- speed automatic transmission(1S)

[Instruments and Switch]

- High-volume backup buzzer(BBH)
- O.K.monitor(OKM)
- For.
 - Aircleaner clogging
 - Electrolyte level
 - Engine coolant level
 - Parking brake warning
 - Seat belt warning
- Speedometer(SM)
- Torqueconverter oil pressure gauge(TPM)
- Torqueconverter oil temp. gauge(TTM)

[Accessories]

- Custom paint works(P)
- Fire extinguisher(FE)
- Rear working light(RWL)
- Rotating warning light(RLY/RLR)

OPTIONAL LOADING ATTACHMENT

- Alternative fork length(LF)
- Bale clamp(LG)
- Fork extension sleeve(EF)
- Fork positioner hydraulic cyl type(FS)
- Fork positioner manual type(FSM)
- Hinged forks(HF)
- Hinged scoop(HFS)
- Lifting-eye(HC)
- Ram(RA)
- Rotating forks hook-on type(RF)
- Side shifter(SS)
- Wide type backrest(WBR)
- Wide type fork carriage(WF)
- Wide view full free 2-stage mast(VFM)
- Wide view full free 3-stage mast(VFHM)