

PARTS AND OPERATION MANUAL

STOW

A DIVISION OF MULTIQUIP INC.

WALK-BEHIND TROWEL SCT36 AND SCT46 SERIES

MODEL # _____

SERIAL # _____

Revision #3 (03/30/05)

© COPYRIGHT 2004, MULTIQUIP INC.

STOW
A DIVISION OF MULTIQUIP INC.

STOW CONSTRUCTION EQUIPMENT

A DIVISION OF MULTIQUIP INC.

POST OFFICE BOX 6254

CARSON, CA 90749

310-537-3700 • 888-252-SCT SERIES[888-252-7869]

FAX: 310-537-1986 • FAX: 800-556-1986

E-MAIL: stow@multiquip.com • WWW: stowmfg.com

PARTS DEPARTMENT:

800-427-1244

FAX: 800-672-7877

SERVICE DEPARTMENT/TECHNICAL ASSISTANCE:

800-478-1244

FAX: 310-631-5032

P/N 21220



WARNING



CALIFORNIA — Proposition 65 Warning

Engine exhaust and some of its constituents, and some dust created by power sanding, sawing, grinding, drilling and other construction activities contains chemicals known to the State of California to cause cancer, birth defects and other reproductive harm. Some examples of these chemicals are:

- Lead from lead-based paints.
- Crystalline silica from bricks.
- Cement and other masonry products.
- Arsenic and chromium from chemically treated lumber.

Your risk from these exposures varies, depending on how often you do this type of work. To reduce your exposure to these chemicals: **ALWAYS** work in a well ventilated area, and work with approved safety equipment, such as dust masks that are specially designed to filter out microscopic particles.

HERE'S HOW TO GET HELP

*PLEASE HAVE THE MODEL AND SERIAL NUMBER
ON-HAND WHEN CALLING*

PARTS DEPARTMENT

800-427-1244 or 310-537-3700

FAX: 800-672-7877 or 310-637-3284

SERVICE DEPARTMENT/TECHNICAL ASSISTANCE

800-478-1244 or 310-537-3700

FAX: 310- 537-4259

WARRANTY DEPARTMENT

888-661-4279, or 310-661-4279

FAX: 310- 537-1173

MAIN

800-421-1244 or 310-537-3700

FAX: 310-537-3927

SCT SERIES TROWEL—TABLE OF CONTENTS

Here's How To Get Help	3
Table Of Contents	4
Parts Ordering Procedures	5
Training Checklist	6
Daily Pre-Operation Checklist	7
Safety Message Alert Symbols	8-9
Rules For Safe Operation	10-11
Operation And Safety Decals	12
Specifications (Trowel)	13
Specifications (Engines)	14
Specifications (Trowel Weights)	14
General Information	15

SCT SERIETROWEL

Controls and Components	16
Basic Engine	17
Assembly and Installation	18-19
Pre-Inspection	20-21
Initial Start-Up (Gasoline Engine)	22-23
Operation	24
Options	25
Maintenance (Engine)	26-27
Maintenance (Trowel)	28-32
Troubleshooting (Trowel)	33-34
Troubleshooting (Engine)	34-35
Explanation of Codes in Remarks Column	36
Suggested Spare Parts	37
Decal Locator	38-39
Standard Handle Assembly	40-41
4-Blade Spider Assembly	42-43
Gearbox Assembly	44-45
Guard Ring Assembly	46-47
Stabilizer Ring Assembly	48-49
Engines Assembly	50-51
Blades & Adjustment Fixture Assembly.	52-53

HONDA GX160K1QX2ENGINE

Air Cleaner Assy.	54-55
Camshaft Assy.	56-57
Carburetor Assy.	58-59
Control Assy.	60-61
Crankcase Cover Assy.	62-63
Crankshaft Assy.	64-65
Cylinder Barrel Assy.	66-67
Cylinder Head Assy.	68-69
Fan Cover Assy.	70-71
Flywheel Assy.	72-73

Fuel Tank Assssembly	74-75
Ignition Coil Assssembly	76-77
Muffler Assssembly	78-79
Piston Assssembly	80-81
Recoil Starter Assssembly	82-83
Gaskets	85
Engine Labels	86-87

HONDA GX240K1QA2ENGINE

Air Cleaner Assssembly	88-89
Camshaft Assssembly	90-91
Carburetor Assssembly	92-93
Control Assssembly	94-95
Crankcase Cover Assssembly	96-97
Crankshaft Assssembly	98-99
Cylinder Barrel Assssembly	100-101
Cylinder Head Assssembly	102-103
Fan Cover Assssembly	104-105
Flywheel Assssembly	106-107
Fuel Tank Assssembly	108-109
Ignition Coil Assssembly	110-111
Muffler Assssembly	112-113
Piston Assssembly	114-115
Recoil Starter Assssembly	116-117
Engine Labels	118-119

Honda GX340K1QAP2 Engine

Air Cleaner Assembly	120-121
Camshaft Assembly	122-123
Carburetor Assembly	124-125
Crankcase Cover Assembly	126-127
Control Assembly	128-129
Cylinder Barrel Assembly	130-131
Cylinder Head Assembly	132-133
Crankshaft Assembly	134-135
Fan Cover Assembly	136-137
Flywheel Assembly	138-139
Fuel Tank Assembly	140-141
Ignition Coil Assembly	142-143
Muffler Assembly	144-145
Piston Assembly	146-147
Recoil Starter Assembly	148-149
Engine Labels	150-151

Terms and Conditions of Sale Parts	152
--	-----

SCT SERIES TROWEL— PARTS ORDERING PROCEDURES

- Dealer account number
- Dealer name and address
- Shipping address (if different than billing address)
- Return fax number
- Applicable model number
- Quantity, part number and description of each part
- Specify preferred method of shipment:
 - UPS Ground
 - UPS Second Day or Third Day*
 - UPS Next Day*
 - Federal Express Priority One (please provide us with your Federal Express account number)*
 - Airborne Express*
 - Truck or parcel post

**Normally shipped the same day the order is received, if prior to 2PM west coast time.*

Earn Extra Discounts when you order by FAX!

All parts orders which include complete part numbers and are received by fax qualify for the following extra discounts:

<u>Number of line items ordered</u>	<u>Additional Discount</u>
1-9 items	3%
10+ items**	5%

Get special freight allowances when you order 10 or more line items via FAX! **

- UPS Ground Service at no charge for freight
- UPS Third Day Service at one-half of actual freight cost

No other allowances on freight shipped by any other carrier.

**Common nuts, bolts and washers (all items under \$1.00 list price) do not count towards the 10+ line items.

DISCOUNTS ARE SUBJECT TO CHANGE

Fax order discount and UPS special programs revised June 1, 1995

**Extra Fax Discount
for Domestic USA
Dealers Only**

**Up to 5%
extra savings!**

**UPS
Special**
For faxed orders only

**Now! Direct TOLL-FREE access
to our Parts Department!**

Toll-free nationwide:

800-421-1244

Toll-free FAX:

800/6-PARTS-7 • 800-672-7877

SCT SERIES TROWEL—TRAINING CHECKLIST

TRAINING CHECKLIST

This checklist will lists some of the minimum requirements for machine maintenance and operation. Please feel free to detach it and make copies. Use this checklist whenever a new operator is to be trained or it can be used as a review for more experienced operator's.

TRAINING CHECKLIST			
NO.	DESCRIPTION	OK?	DATE
1	Read Operator's Manual completely.		
2	Machine layout, location of components, checking of engine and gearbox fluid level.		
3	Fuel system, refueling procedure.		
4	Operation of controls (machine not running).		
5	Safety controls, safety stop switch operation.		
6	Emergency stop procedures.		
7	Startup of machine.		
8	Maneuvering.		
9	Pitching.		
10	Concrete finishing techniques.		
11	Shutdown of machine.		
12	Lifting of machine.		
13	Machine transport and storage.		

Operator _____ Trainee _____

COMMENTS:

SCT SERIES TROWEL— DAILY PRE-OPERATION CHECKLIST

DAILY PRE-OPERATION CHECKLIST

DAILY PRE-OPERATION CHECKLIST	
1	Engine Oil Level.
2	Gearbox Fluid Level.
3	Condition of Blades.
4	Blade Pitch Operation.
5	Safety Stop Switch Operation.

COMMENTS:

SCT SERIES TROWEL— SAFETY MESSAGE ALERT SYMBOLS

FOR YOUR SAFETY AND THE SAFETY OF OTHERS!

Safety precautions should be followed at all times when operating this equipment. Failure to read and understand the Safety Messages and Operating Instructions could result in injury to yourself and others.

NOTE

This Owner's Manual has been developed to provide complete instructions for the safe and efficient operation of the SCT SERIES WALK-BEHIND TROWEL. For engine maintenance information, please refer to the engine manufacturers instructions for data relative to its safe operation.

Before using this WALK-BEHIND TROWEL, ensure that the operating individual has read and understands all instructions in this manual.

SAFETY MESSAGE ALERT SYMBOLS

The three (3) Safety Messages shown below will inform you about potential hazards that could injure you or others. The Safety Messages specifically address the level of exposure to the operator, and are preceded by one of three words: **DANGER**, **WARNING**, or **CAUTION**.



DANGER: You **WILL** be **KILLED** or **SERIOUSLY** injured if you **DO NOT** follow directions.



WARNING: You **CAN** be **KILLED** or **SERIOUSLY** injured if you **DO NOT** follow directions.



CAUTION: You **CAN** be injured if you **DO NOT** follow directions.

Potential hazards associated with trowel operation will be referenced with "**Hazard Symbols**" which appear throughout this manual, and will be referenced in conjunction with Safety "**Message Alert Symbols**".

HAZARD SYMBOLS



Lethal Exhaust Gases



Engine exhaust gases contain poisonous carbon monoxide. This gas is colorless and odorless, and can cause death if inhaled. **NEVER** operate this equipment in a confined area or enclosed structure that does not provide ample free flow air.



Explosive Fuel



Gasoline is extremely flammable, and its vapors can cause an explosion if ignited. **DO NOT** start the engine near spilled fuel or combustible fluids. **DO NOT** fill the fuel tank while the engine is running or hot. **DO NOT** overfill tank, since spilled fuel could ignite if it comes into contact with hot engine parts or sparks from the ignition system. Store fuel in approved containers, in well-ventilated areas and away from sparks and flames. **NEVER** use fuel as a cleaning agent.



Burn Hazards



Engine components can generate extreme heat. To prevent burns, **DO NOT** touch these areas while the engine is running or immediately after operations. **NEVER** operate the engine with heat shields or heat guards removed.



Rotating Parts



NEVER operate equipment with covers, or guards removed. Keep fingers, **hands**, **hair** and **clothing** away from all moving parts to prevent injury.

SCT SERIES TROWEL— SAFETY MESSAGE ALERT SYMBOLS



Accidental Starting



OFF

ALWAYS place the engine ON/OFF switch in the **OFF** position, when the trowel is not in use.



Respiratory Hazard



ALWAYS wear approved respiratory protection.



Over Speed Conditions



NEVER tamper with the factory settings of the engine governor or settings. Personal injury and damage to the engine or equipment can result if operating in speed ranges above maximum allowable.



Sight and Hearing hazard

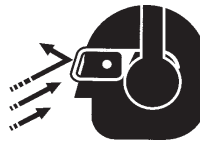

ALWAYS wear approved eye and hearing protection.



Equipment Damage Messages

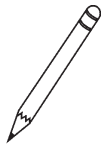

This **walk-behind trowel**, other property, or the surrounding environment could be damaged if you do not follow instructions.

Other important messages are provided throughout this manual to help prevent damage to your trowel, other property, or the surrounding environment.

SCT SERIES TROWEL — RULES FOR SAFE OPERATION

CAUTION:



Failure to follow instructions in this manual may lead to serious injury or even death! This equipment is to be operated by trained and qualified personnel only! This equipment is for industrial use only.

The following safety guidelines should always be used when operating the SCT SERIES walk-behind trowel.

SAFETY

- **DO NOT** operate or service this equipment before reading this entire manual.



- This equipment should not be operated by persons under 18 years of age.

- **NEVER** operate the trowel without proper protective clothing, shatterproof glasses, steel-toed boots and other protective devices required by the job.



- **NEVER** operate this equipment when not feeling well due to fatigue, illness or taking medicine.



- **NEVER** operate the trowel under the influence of drugs or alcohol.



- **NEVER** use accessories or attachments, which are not recommended by **SCT SERIES** for this equipment. Damage to the equipment and/or injury to user may result.

- Manufacture does not assume responsibility for any accident due to equipment modifications.

- Whenever necessary, replace nameplate, operation and safety decals when they become difficult to read.

- **ALWAYS** check the trowel for loosened screws, nuts, or bolts before starting.

- **NEVER** touch the hot exhaust manifold, muffler or cylinder. Allow these parts to cool before servicing the trowel.

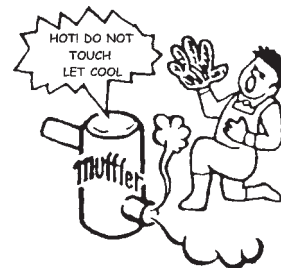

- **High Temperatures** – Allow the engine to cool before adding fuel or performing service and maintenance functions. Contact with **hot!** components can cause serious burns.

- The engine of this trowel requires an adequate free flow of cooling air. **NEVER** operate the trowel in any enclosed or narrow area where free flow of the air is restricted. If the air flow is restricted it will cause serious damage to the trowel's engine and may cause injury to people. Remember the trowel's engine gives off **DEADLY** carbon monoxide gas.

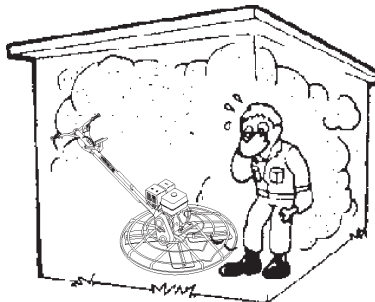

Remember the trowel's engine gives off **DEADLY** carbon monoxide gas.

- **ALWAYS** refuel in a well-ventilated area, away from sparks and open flames.

- **ALWAYS** use extreme caution when working with **flammable** liquids. When refueling, **stop the engine** and allow it to cool.



- **NEVER** smoke around or near the machine. Fire or explosion could result from **fuel vapors**, or if fuel is spilled on a **hot!** engine.



- **NEVER** operate the trowel in an explosive atmosphere or near combustible materials. An explosion or fire could result causing severe **bodily harm or even death**.

- Topping-off the fuel tank filler port is dangerous, as it tends to spill fuel.

SCT SERIES TROWEL — RULES FOR SAFE OPERATION

- **DO NOT** operate this trowel unless all guards and safety devices are attached and in place. See Pages 16 and 17.
- **ALWAYS** use proper lifting techniques when moving the trowel.
- **ALWAYS** check to make sure that the operating area is clear before starting the engine.
- **ALWAYS** test the safety **safety stop switch** devices before operating the trowel.
- **NEVER** place your **feet** or **hands** inside the guard rings while starting or operating this equipment.
- **AVOID** wearing jewelry or loose fitting clothing that may snag on the controls or moving parts, this can cause a serious injury.
- **ALWAYS** keep clear of **rotating** or **moving parts** while operating the trowel.
- **NEVER** leave the machine **unattended** while running.
- **Moving Parts** – Shut down the engine before performing service or maintenance functions. Contact with moving parts can cause serious injury.
- Keep the trowel in proper running condition.
- Make sure that there is no buildup of concrete, grease, oil or debris on the trowel.
- Fix damage to the trowel immediately and always replace broken parts.
- Dispose of hazardous waste properly. Examples of potentially hazardous waste are used **motor oil, fuel** and **fuel filters**.
- **High Temperatures** – Allow the machine and engine to **cool** before adding fuel or performing service and maintenance functions. Contact with **hot!** components can cause serious burns.

Maintenance Safety

- Disconnect the spark plug wires before attempting any type of service.
- Securely support any machine components that must be raised.
- **NEVER** lubricate components or attempt service on a running machine.
- **DO NOT** use food or plastic containers to dispose of hazardous waste.
- **DO NOT** pour **waste, oil** or **fuel** directly onto the ground, down a drain or into any water source.

CAUTION

Emergencies

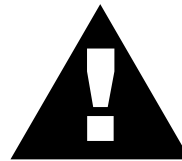

- **ALWAYS** know the location of the nearest **fire extinguisher** and **first aid kit**. Know the location of the nearest telephone. Also know the phone numbers of the nearest **ambulance, doctor** and **fire department**. This information will be invaluable in the case of an **emergency**.

SCT SERIES TROWEL — OPERATION AND SAFETY DECALS

Machine Safety Decals

The SCT SERIES walk-behind trowel is equipped with a number of safety decals. These decals are provided for operator safety and maintenance information. Figure 1 below illustrates these decals as they appear on the machine. Should any of these decals become unreadable, replacements can be obtained from your dealer.



P/N 25378-001



P/N 25265-001

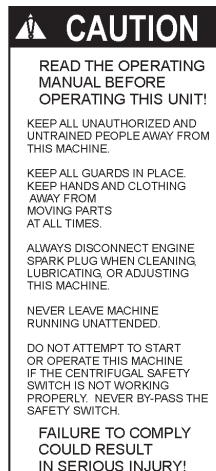

P/N 25264-001



P/N 30053-001



P/N 30054-001



P/N 25349-001

	Symbol indicates that it is mandatory to wear safety glasses, safety helmet and ear protection. P/N 11247 (Part of decal kit 12620)		Symbol indicates that it is mandatory to wear safety shoes, with extra protection (steel toed). P/N 11247 (Part of decal kit 12620)
	Symbol indicates that it is mandatory to wear gloves. P/N 11247 (Part of decal kit 12620)		CONTACT STOW SERVICE DEPT.
	Radiating heat symbol. Symbol indicates equipment is hot. P/N 11246 (Part of decal kit 12620)		This is the symbol for belt drive. P/N 11246 (Part of decal kit 12620)
	Symbol for examining or checking of the machine. Mostly used for maintenance. Check lubrication oil in gearbox. P/N 11246 (Part of decal kit 12620)		This is the symbol for gear drive. P/N 11246 (Part of decal kit 12620)
	Symbol depicts the preferred point on the trowel for lifting and moving the trowel. P/N 11246 (Part of decal kit 12620)		This symbol shows the direction of rotation (counter-clockwise) of that particular part of the equipment. P/N 11246 (Part of decal kit 12620)

Figure 1. SCT SERIES Trowel Decals

SCT SERIES TROWEL — SPECIFICATIONS (TROWEL)

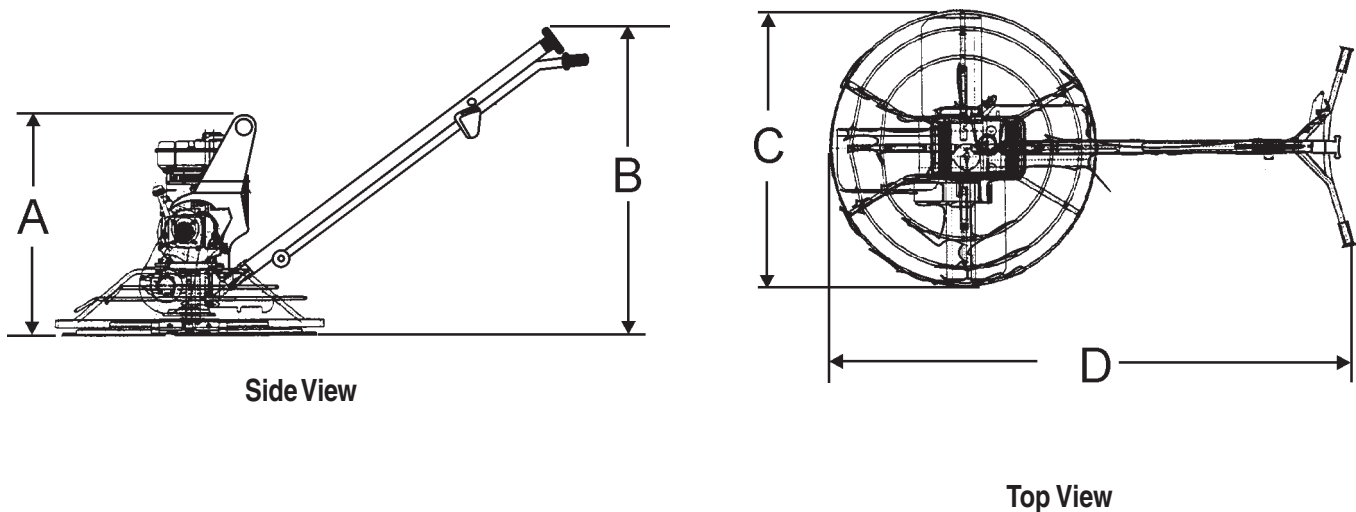

Figure 2. SCT SERIES Trowel Dimensions

Table 1. STOW Trowel Specifications		
MODEL	SCT36	SCT46
A- Height (Lifting Hook)	36.7 in. (931.6 mm)	34.5 in. (876.2 mm)
B- Height Engagement Lever)	41.4 in. (1,044.2 mm)	41.1 in. (1,044.2 mm)
C-Width	36.5 in. (927.1 mm)	46.0 in. (1,168.4 mm)
D-Length	70.5 in. (1,789.4 mm)	75.2 in. (1,910.1 mm)
Weight – Operating	SEE TABLE 3	
Sound Pressure ¹	94 db	97 db
Vibration ²	2.0g (19.6 m/s ²)	2.5g (24.5 m/s ²)
Ring Diameter	36.5 in. (92.7 cm)	46 in. (117 cm)
Number of Blades	4	4
Blade Tip Speed – FPM (m/s)	1,290 fpm (6.5 m/s)	1,290 fpm (6.5 m/s)
Rotor – RPM (Gasoline)	144 @ 3800 rpm	144 @ 3800 rpm
Path Width – in. (cm)	36 in. (91.44 cm)	46 in. (116.84)

NOTE:

1. Sound pressure is a weighted measure. Measured at the operators ear position while the walk-behind trowel is operating at full throttle on concrete in a manner most often experienced in “*normal*” circumstances. Sound pressure may vary depending upon the condition of the concrete. Hearing protection is always recommended.
2. The vibration level indicated is the maximum RMS (Root Mean Square) value obtained at the handle grip while operating the walk-behind trowel on curing concrete in a manner most often experienced in “*normal*” circumstances. Values were obtained from all three axes of motion. The values shown represent the maximum RMS value from these measurements.

SCT SERIES TROWEL— SPECIFICATIONS (ENGINES)

Table 2. Specifications (Engines)

Model	HONDA GX160QX2	HONDA GX240K1QA2	HONDA GX340K1QAP2
Type	Air-cooled 4 stroke, Single Cylinder, OHV, Horizontal Shaft Gasoline Engine	Air-cooled 4 stroke, Single Cylinder, OHV, Horizontal Shaft Gasoline Engine	Air-cooled 4 stroke, Single Cylinder, OHV, Horizontal Shaft Gasoline Engine
Bore X Stroke	2.7 in. x 1.8 in. (68 mm x 45 mm)	2.9 in. x 2.3 in. (73 mm x 58 mm)	3.2 in. x 2.5 in. (82 mm x 64 mm)
Displacement	9.9 cu-in. (163 cc)	14.81 cu-in. (242cc)	20.6 cu-in. (337cc)
Max Output	5.5 H.P./4000 R.P.M.	8.0 H.P./3600 R.P.M.	11.0 H.P./3600 R.P.M.
Fuel Tank Capacity	0.95 U.S. gal. (3.6 liters)	1.59 U.S. gal. (6 liters)	1.72 U.S. gal (6.5 liters)
Fuel	Unleaded Automobile Gasoline	Unleaded Automobile Gasoline	Unleaded Automobile Gasoline
Lube Oil Capacity	0.63 U.S. qt. (0.60 liter)	1.16 U.S. qt. (1.1 liters)	1.16 U.S. qt. (1.1 liters)
Speed Control Method	Centrifugal Fly-weight Type	Centrifugal Fly-weight Type	Centrifugal Fly-weight Type
Starting Method	Recoil Start	Recoil Start	Recoil Start
Dimension (L x W x H)	12.0 x 14.3 x 13.2 in. (304 x 362 x 335 mm)	14.0 x 16.9 x 16.1 in. (355 x 430 x 410 mm)	15.0 x 17.7 x 17.4 (380 x 450 x 443 mm)
Dry Net Weight	33.1 lbs. (15.0 Kg)	55.1 lbs. (25 Kg)	68.4 lbs. (31 Kg)

Table 3. Specifications (Trowel Weights)

MODEL	POWER SOURCE	OPERATING WEIGHT (with handle)	SHIPPING WEIGHT
SCT36H55	5.5 HP Honda	190 lbs. (87 Kg)	230 lbs. (105 Kg)
SCT36H80	8 HP Honda	214 lbs. (97 Kg)	254 lbs. (116 Kg)
SCT46H80	8 HP Honda	242 lbs. (110 Kg)	292 lbs. (133 Kg)
SCT46H11	11 HP Honda	295 lbs. (134 Kg)	355 lbs. (161 Kg)

SCT SERIES TROWEL—GENERAL INFORMATION

SCT SERIES Walk-Behind Trowel Familiarization

This walk-behind trowel is designed for the **floating** and **finishing** of concrete slabs.

Take a walk around the trowel. Take notice of all the major components (see Figure 3, pages 16 and 17) like the engine, blades, quick adjust control, (on those equipped models), air cleaner, centrifugal stop switch etc. Check that there is always oil in the engine.

Read all the safety instructions carefully. Safety instructions will be found throughout this manual and on the trowel. Keep all safety information in good, readable condition. Operators should be well trained on the operation and maintenance of the trowel.

Before using your trowel, test it on a flat watered down section of finished concrete that is free of any debris and other objects.

This trial test run will increase your confidence in using the trowel and at the same time it will familiarize you with the trowel's controls. In addition you will understand how the trowel handles under actual conditions.

Engines

The 36" trowel is available with a 5.5 HP **HONDA** or an 8.0 HP **HONDA** gasoline engine while the 46" trowel is available with an 8.0 HP **HONDA** or an 11.0 HP **HONDA** gasoline engine. Refer to the engine owner's manual for instructions regarding the operation and maintenance of your engine. The engine manual is included with your trowel at the time of shipment. Please contact your nearest Multiquip Dealer for a replacement should the original manual disappear or become unusable.

Drive System

Power is transferred from the engine to the gearbox input shaft via a V-belt or pulley drive system. The pulley engages using a centrifugal clutch.

Gearbox

The **gearbox** is located beneath the engine and transfers power to the **rotor** or **spider** assembly. The gearbox controls the rotational speed of the trowel and is equipped with two shafts (input and output).

Spider

The vertical output shaft of the gearbox connects to a cast hub called the **spider**. The spider has 4 arms that extend outward that are used for attachment of blades or other accessories. Remember as the gearbox output shaft rotates so does the spider assembly.

Blades

The blades of the trowel finish the concrete as they are rotated around the surface. Blades are classified as **combination** (8 inches wide), **float** (10 or 8 inches wide), and **finish** (6 inches wide). This trowel comes equipped with four blades per rotor equally spaced in a radial pattern and attached to vertical rotating shaft by means of a **spider assembly**.

Centrifugal Stop Switch

In the event of a trowel runaway condition, (operator releases the handle), a **centrifugal stop switch** will stop the engine and bring the trowel to a halt.

CAUTION

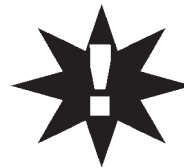

NEVER attempt to **lift** the trowel by yourself. **ALWAYS** get the assistance of another person to help lift the trowel or use a crane or lifting device to move the trowel.

Moving the SCT SERIES Walk-Behind Trowel

This walk-behind trowel is designed to be moved and handled in several ways. One way to lift the trowel is to use an **optional lifting tube**. See page 24, Figure 20. When using the lifting tube, always use **two persons** to lift the trowel.

These models have a **lifting bail** installed so strap or chain can be attached, allowing a forklift or crane to lift the trowel up onto a slab of concrete. Use a lifting device of adequate lifting capacity to lift the trowel.

Training

For proper training, please use the "**TRAINING CHECKLIST**" located in the front of this manual (Page 6). This checklist will provide an outline for an experienced operator to provide training to a new operator.

SCT SERIES TROWEL— CONTROLS AND COMPONENTS

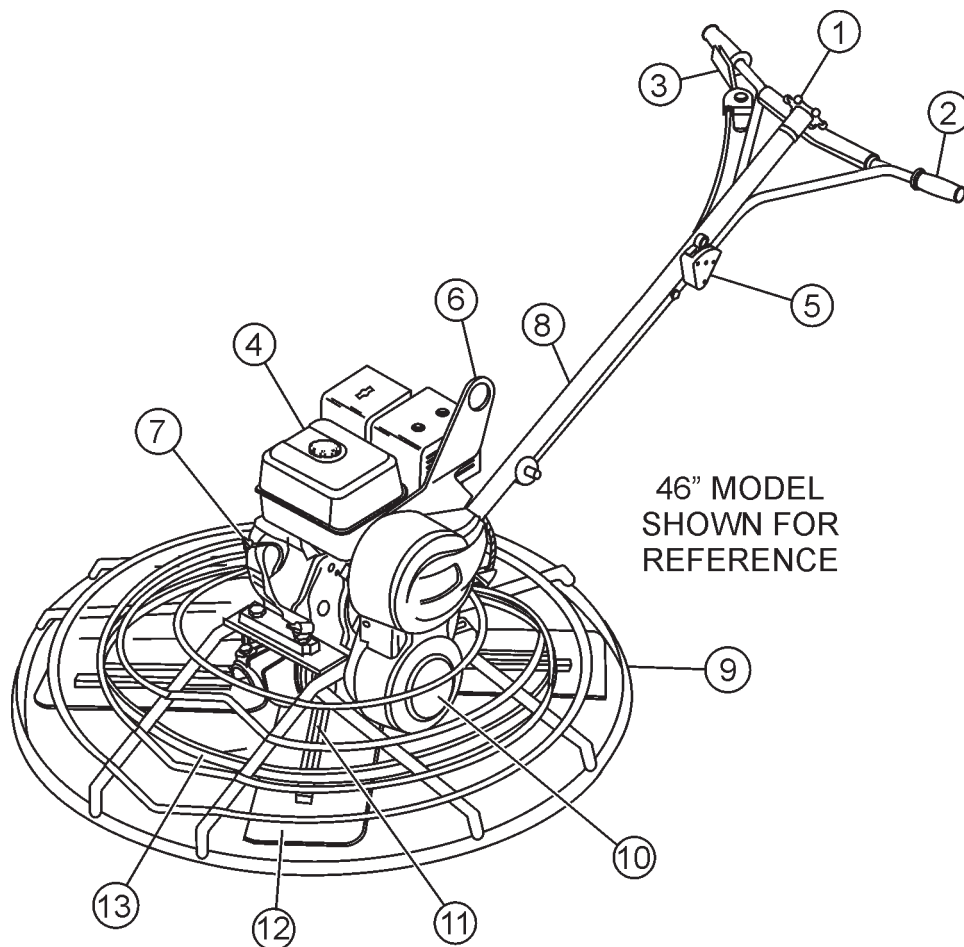

Figure 3. SCT SERIES Walk-Behind Trowels

Figure 3 shows the location of the basic controls or components, for the SCT SERIES trowel. Listed below is a brief explanation of each control or component

- 1. Pitch Control** - Turn this "Star Wheel" clockwise for increase blade pitch, and counter-clockwise for decrease blade pitch
- 2. Hand Grip/Handle Bar** - When operating the trowel, place both hands on each grip to maneuver the trowel. Replace hand grips when they become worn or damaged.
- 3. Throttle** - Controls engine speed.
- 4. Engine** - This trowel uses a Honda gasoline engine.
- 5. Centrifugal Safety Stop Switch** - In the event the operator loses control of the trowel, this switch will shut-down the engine.
- 6. Trowel Lifting Point** - Use a hoist, forklift, or other suitable lifting device to lift the trowel on and off the concrete slab.
- 7. Engine ON-OFF Switch** - Turn to the "ON" position for starting the engine and to the "OFF" position to prevent the engine from starting.
- 8. Main Tube** - Houses throttle control and pitch cables.
- 9. Guard Ring** - **NEVER!** put hands or feet inside guard ring.
- 10. V-Belt Cover** - Remove this cover to gain access to the V-belt. **NEVER** operate the trowel with this cover removed.
- 11. Trowel Arm** - **NEVER** operate the trowel with a bent, broken or out of adjustment trowel arm. If the blades show uneven wear patterns or some blades wear out faster than others, the trowel arm may need to be adjusted. Use the trowel arm adjustment tool P/N 1817 to adjust the trowel arms.
- 12. Blades** - This trowel is equipped with combination blades. These blades are versatile and should take care of most troweling needs. In addition float discs can be attached to the trowel arms that will allow the trowel to float on "wet" concrete.
- 13. Stabilizer Ring** - Reduces trowel arm vibration. Helps stabilize trowel arm.

SCT SERIES TROWEL— BASIC ENGINE

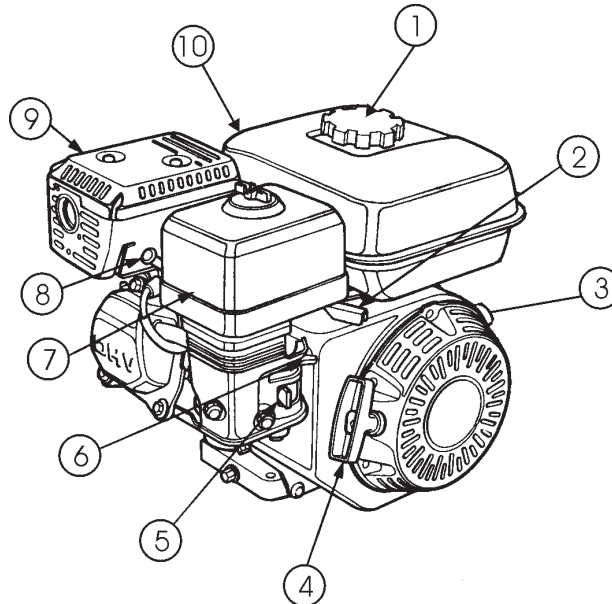
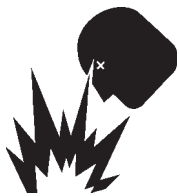

Figure 4. Engine Controls and Components

INITIAL SERVICING (ENGINE)

The engine (Figure 4) must be checked for proper lubrication and filled with fuel prior to operation. Refer to the manufacturers engine manual for instructions & details of operation and servicing.

1. **Fuel Filler Cap** – Remove this cap to add unleaded gasoline to the fuel tank. Make sure cap is tightened securely. **DO NOT** over fill.



Adding fuel to the tank should be done only when the engine is stopped and has had an opportunity to cool down. In the event of a fuel spill, **DO NOT** attempt to start the engine until the fuel residue has been completely wiped up, and the area surrounding the engine is dry.

2. **Throttle Lever** – Used to adjust engine RPM speed (lever advanced forward **SLOW**, lever back toward operator **FAST**).
3. **Engine ON/OFF Switch** – ON position permits engine starting, OFF position stops engine operations.
4. **Recoil Starter (pull rope)** – Manual-starting method. Pull the starter grip until resistance is felt, then pull briskly and smoothly.

5. **Fuel Valve Lever** – **OPEN** to let fuel flow, **CLOSE** to stop the flow of fuel.
6. **Choke Lever** – Used in the starting of a cold engine, or in cold weather conditions. The choke enriches the fuel mixture.
7. **Air Cleaner** – Prevents dirt and other debris from entering the air intake system. Remove wing-nut on top of air filter cannister to gain access to filter element.

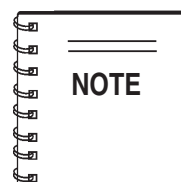

Operating the engine without an air filter, with a damaged air filter, or a filter in need of replacement will allow dirt to enter the engine, causing rapid engine wear

8. **Spark Plug** – Provides spark to the ignition system. Set spark plug gap to 0.6 - 0.7 mm (0.028 - 0.031 inch) Clean spark plug once a week.
9. **Muffler** – Used to reduce noise and emissions.



Engine components can generate extreme heat. To prevent burns, **DO NOT** touch these areas while the engine is running or immediately after operating. **NEVER** operate the engine with the muffler removed.

10. **Fuel Tank** – Holds unleaded gasoline. For additional information refer to engine owner's manual.

SCT SERIES TROWEL — ASSEMBLY AND INSTALLATION

Assembly and Installation

Before the trowel can be put into operation there are some components that must be installed before the trowel can be used. This section provided general instructions on how to install those components.

Handle Tube Installation

1. Install the **handle tube** to the gearbox as shown in (Figure 5). The mounting hardware should be contained in the shipping container.

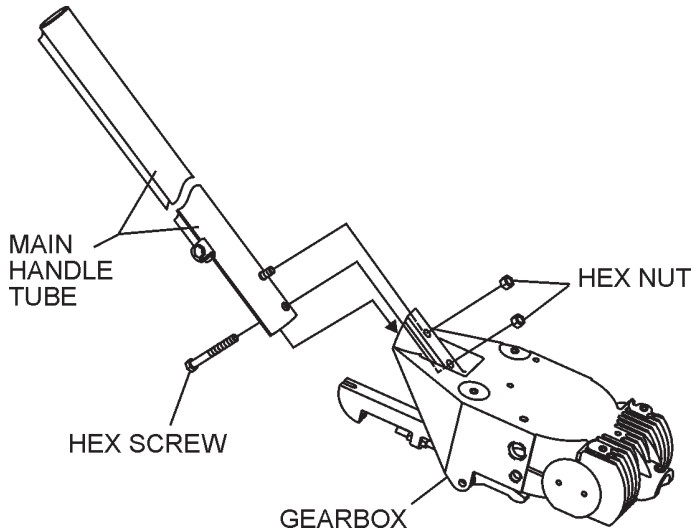

Figure 5. Handle Tube Installation

Throttle Cable Installation

1. Set the **throttle** (Figure 6) to the idle position (lever away from the operator).

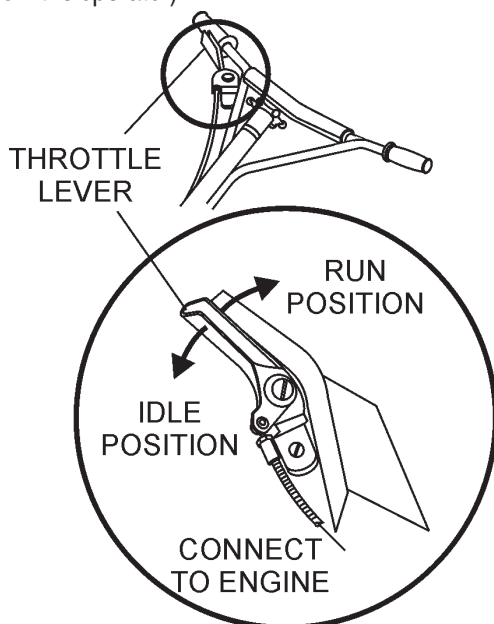

Figure 6. Throttle

2. Connect the throttle cable to the engine. (Figure 7). (The air cleaner housing may have to be removed to provide access for throttle cable installation.) When connecting the cable housing, make sure that no more than **1/4" (6.4mm)** of the cable housing protrudes past the housing clamp on the engine.

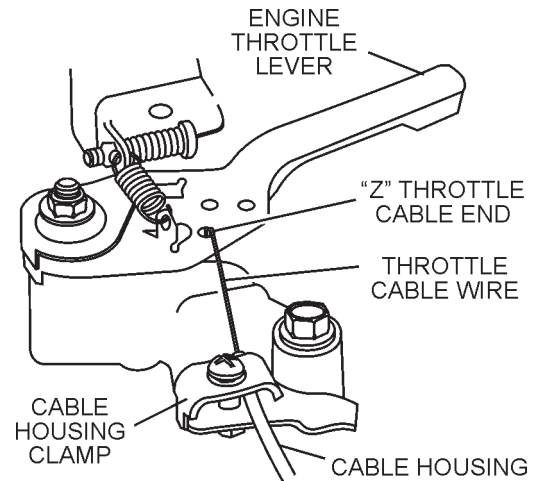

Figure 7. Throttle Cable Connection

3. Tighten cable clamp screw.
4. After the cable has been installed on the engine, work the throttle lever to verify the throttle cable is at the proper length. Adjust the cable as necessary.
5. Reinstall the air cleaner housing if previously removed.

SCT SERIES TROWEL — ASSEMBLY AND INSTALLATION

Safety Stop Wire

Locate the **SAFETY STOP** wire protruding from the handle tube (Figure 8) and connect it to the tail wire on the engine. Test the safety stop switch to insure proper operation.

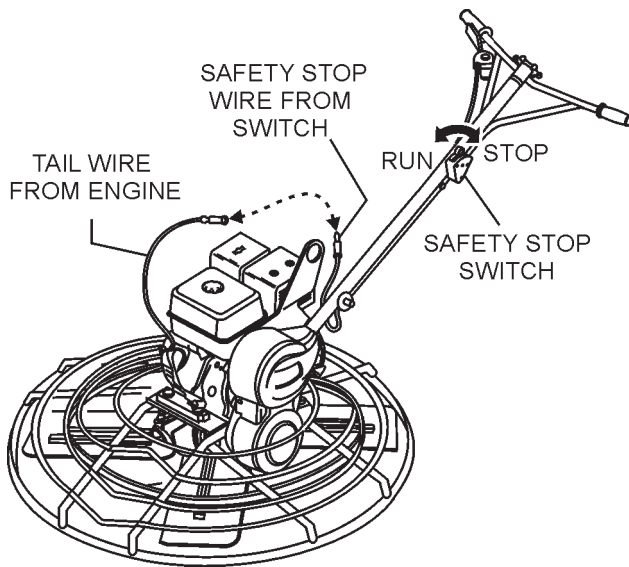

Figure 8. Engine Safety Stop Wire Connection

Pitch Cable Installation

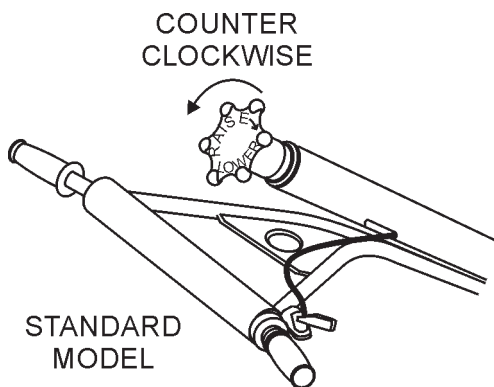

Figure 9. "No Pitch" Position

1. Expose the pitch cable to maximum by adjusting the handle pitch to the "no pitch" position. On the standard model turn the pitch control counter-clockwise, (Figure 9).

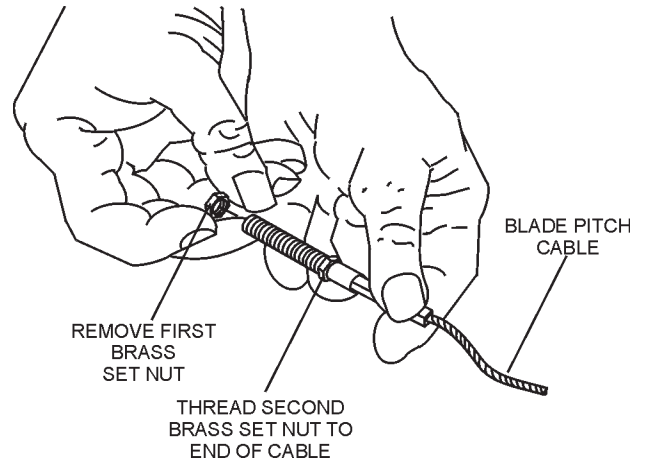

Figure 10. Blade Pitch Cable

2. Remove one brass set nut from the blade pitch cable end as shown in (Figure 10).
3. Thread the second brass set nut towards the cable as far as possible.
4. Insert the cable end through the yoke eyelet (Figure 11) Tighten the first brass set nut by hand to remove all the slack from the cable.

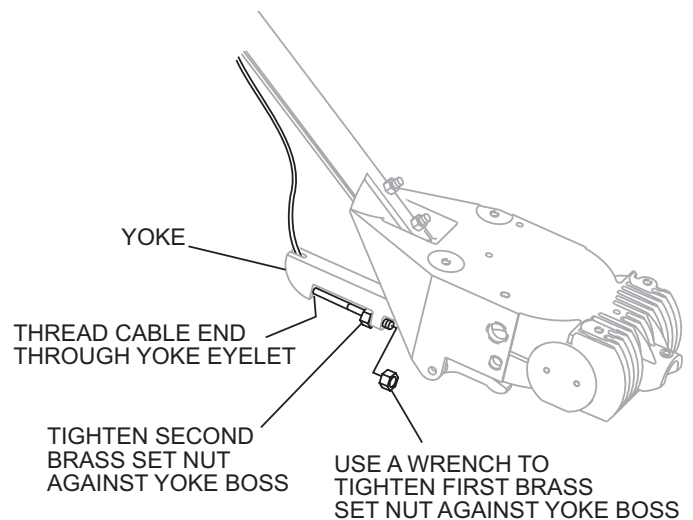

Figure 11. Cable Yoke Attachment

5. Using a wrench, tighten the second brass set nut up against the yoke boss. This will lock the cable in place.
6. Use a wrench and finish tightening the first brass set nut up against the yoke boss.

SCT SERIES TROWEL— PRE-INSPECTION

CAUTION



NEVER operate the trowel in a confined area or enclosed area structure that does not provide ample **free flow of air**.



ALWAYS wear approved eye and hearing protection before operating the trowel.

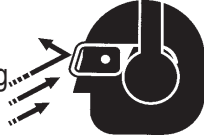

NEVER place hands or feet inside the guard rings while the engine is running. **ALWAYS** shut the engine down before performing any kind of maintenance service on the trowel.



It is recommended that the trowel's **safety stop switch** is used to stop the engine after every use. Doing this will verify that the switch is working properly and presents no danger to the operator.

Before Starting

1. Read safety instructions at the beginning of manual.
2. Clean the **trowel**, removing dirt and dust, particularly the air filter and carburetor.
3. Check the air filter for dirt and dust. If air filter is dirty, replace air filter with a new one as required.
4. Check carburetor for external dirt and dust. Clean with dry compressed air.
5. Check fastening nuts and bolts for tightness.

Engine Oil Check

1. To check the engine oil level, place the trowel on secure level ground with the engine stopped.
2. Remove the filler dipstick from the engine oil filler hole (Figure 12) and wipe it clean.

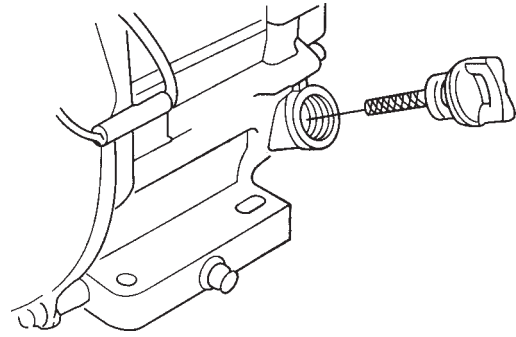
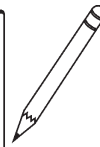
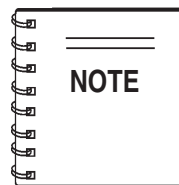

Figure 12. Engine Oil Dipstick (Removal)

3. Insert and remove the dipstick without screwing it into the filler neck. Check the oil level shown on the dipstick.
4. If the oil level is low (Figure 13), fill to the edge of the oil filler hole with the recommended oil type (Table 4). Maximum oil capacity is 400 cc.



Reference manufacturer engine manual for specific servicing instructions.

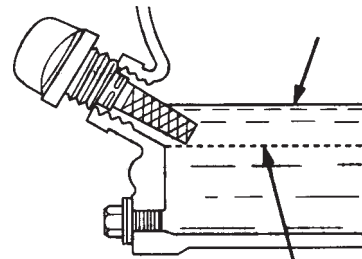

Figure 13. Engine Oil Dipstick (Oil Level)

Table 4. Oil Type

Season	Temperature	Oil Type
Summer	25°C or Higher	SAE 10W-30
Spring/Fall	25°C~10°C	SAE 10W-30/20
Winter	0°C or Lower	SAE 10W-10



CAUTION



Motor fuels are highly flammable and can be dangerous if mishandled. **DO NOT** smoke while refueling. **DO NOT** attempt to refuel the trowel if the engine is **hot!** or **running**.

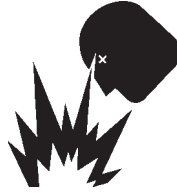

Fuel Check

1. Remove the gasoline cap located on top of fuel tank.
2. Visually inspect to see if fuel level is low. If fuel is low, replenish with unleaded fuel.
3. When refueling, be sure to use a strainer for filtration. **DO NOT** top-off fuel. Wipe up any spilled fuel.



NEVER! disable or disconnect the safety stopswitch. It is provided for operator safety. Injury may result if it is **disable, disconnected** or **improperly maintained**.

Gearbox Oil

1. Determine if the **gearbox** oil is low by viewing the oil sight glass/fill plug located on the side of the gearbox. This plug will be marked by the "**check**" decal. See (Figure 14). The correct level of the lubrication oil should be to the bottom of the sight glass/fill plug.

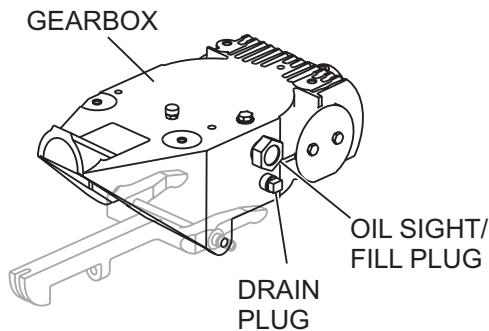

Figure 14. Gearbox

2. If lubrication oil cannot be seen in the sight glass, fill with type ISO 680 (P/N 10139) gearbox lubricant oil until the oil will show at the center of the oil sight glass when the gearbox is level..

V-belt Check

A worn or damaged V-belt can adversely affect the performance of the trowel. If a V-belt is defective or worn simply replace the V-belt as outlined in the maintenance section of this manual.

Blade Check

Check for worn or damaged blades. Check to see if one blade is worn out while the others look new. If this is the case there could be a blade pitch problem. Refer to the maintenance section of this manual for blade pitch adjustment procedure. Always replace any worn or damaged blades.

CONTROLS

Safety Stop Switch

This trowel has been equipped with a safety safety stop switch. Safety stop switches should be tested every time the engine is started.

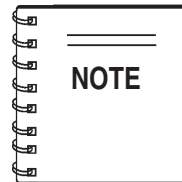

NEVER! disable or disconnect the safety stopswitch. It is provided for operator safety. Injury may result if it is **disable, disconnected** or **improperly maintained**.

Centrifugal Type Safety Stop Switch

(Figure 15) The switching mechanism of this switch should operate freely and should **always** be kept in this condition. With the switch in the "**OFF**" position, the engine should not start or run. The purpose of this switch is to stop the engine in a runaway situation, (i.e. the operator releasing the handle during operation).

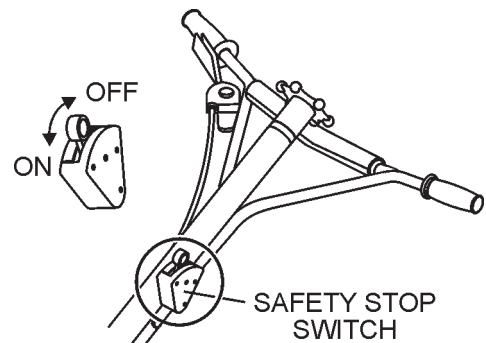

Figure 15. Centrifugal Safety Stop Switch

SCT SERIE STROWEL — INITIAL START-UP

This section is intended to assist the operator with the initial start-up of the walk-behind trowel. It is extremely important that this section be read carefully before attempting to use the trowel in the field.

DO NOT use your trowel until this section is thoroughly understood.

CAUTION



DO NOT attempt to operate the trowel until the Safety, General Information and Inspection sections of this manual have been read and thoroughly understood. Depending on engine manufacturer, operating steps may vary. See engine manufacturer's operating manual. The following start-up procedure makes reference to a **HONDA Gasoline Engine (Manual Start)**.

LIFTING THE TROWEL

CAUTION



When lifting of the trowel is required always use **two people** to lift the trowel onto a slab. If another person is not available attach a crane or lifting device to the trowel's lifting bale.

With one person lifting from the main handle (Figure 16), and another person lifting from the front of the frame, lift the trowel onto a slab.

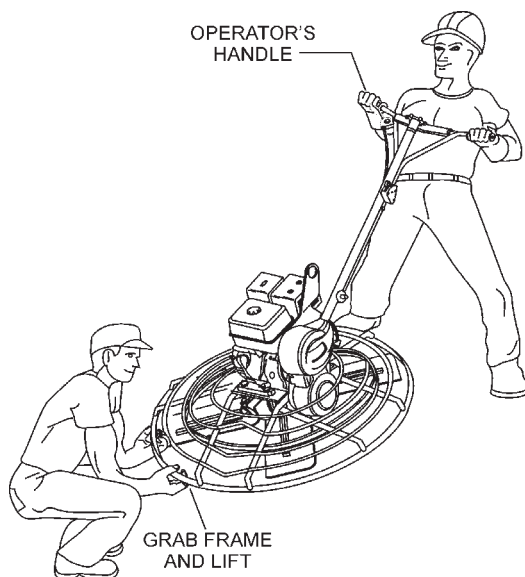
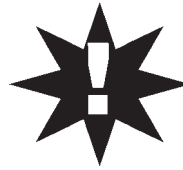

Figure 16. Lifting the Trowel

CAUTION



The trowel must be stabilized by the person carrying the **operator's handle** (Figure 16). If it is not stabilized properly the handle may swing around and **flip** the trowel, thus causing damage to the trowel and bodily injury.

Lifting Bail

A lifting bail is provided at an optimal lifting point for moving the trowel. A **hoist** or **forklift** can be used to lift the trowel up onto a concrete slab. A **crane** can be used to lift the trowel onto a building.

Extra care **MUST** be taken when lifting the machine off the ground. Serious damage to the machine or personal injury could be caused by dropping a trowel.

Starting the Engine

1. Place the engine **fuel valve lever** (Figure 17) to the "ON" position.

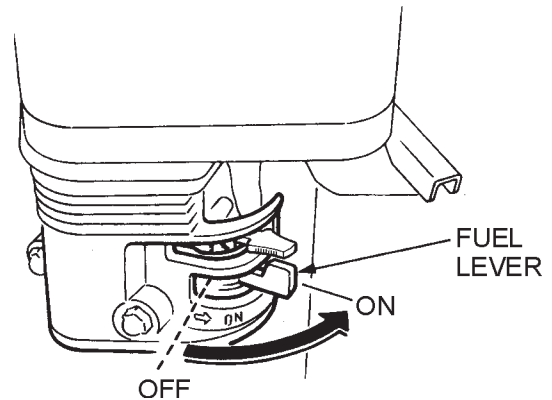

Figure 17. Engine Fuel Valve Lever

2. Make sure the **throttle** (Figure 18) is in the "idle" position.

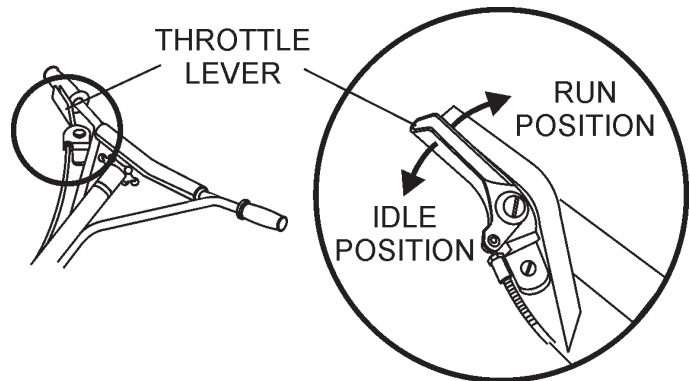

Figure 17. Throttle (Idle Position)

SCT SERIES TROWEL — INITIAL START-UP

- Place the **centrifugal safety stop switch** (Figure 19) in the "ON" position.

CAUTION



NEVER disable or disconnect the centrifugal safety stop switch. It is provided for the operators' safety and injury may result if it is disabled, disconnected or improperly maintained.

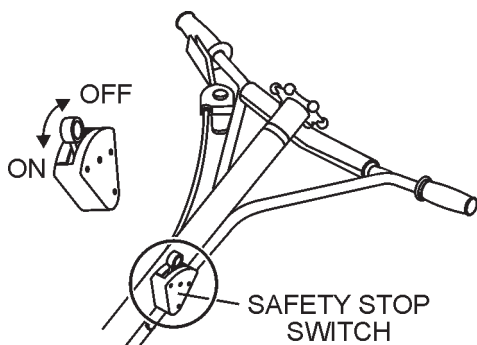

Figure 19. Centrifugal Safety Stop Switch

- Place the **Choke Lever** (Figure 20) in the "CLOSED" position.

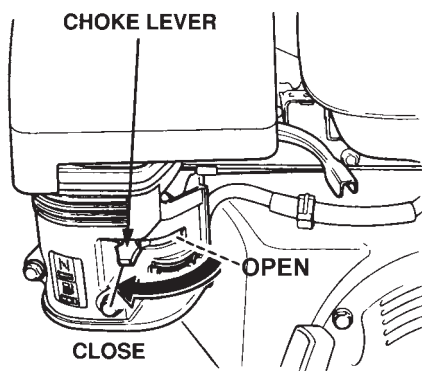

Figure 20. Engine Choke Lever

- Grasp the starter grip (Figure 21) and slowly pull it out. The resistance becomes the hardest at a position corresponding to the compression point. Pull the starter grip briskly and smoothly for starting.

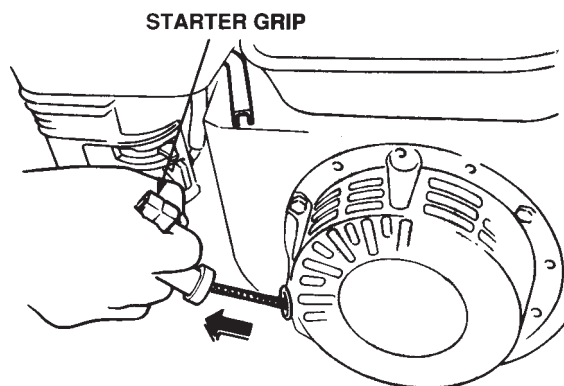

Figure 21. Starter Grip

- If the engine has started, slowly return the choke lever (Figure 20) to the "OPEN" position. If the engine has not started repeat steps 1 through 5.
- Before the trowel is placed into operation, run the engine for several minutes. Check for fuel leaks, and noises that would associate with a loose guard ring and/or covers.
- To begin troweling, move the throttle lever (Figure 22) toward the "RUN" position by pulling back toward the operator..

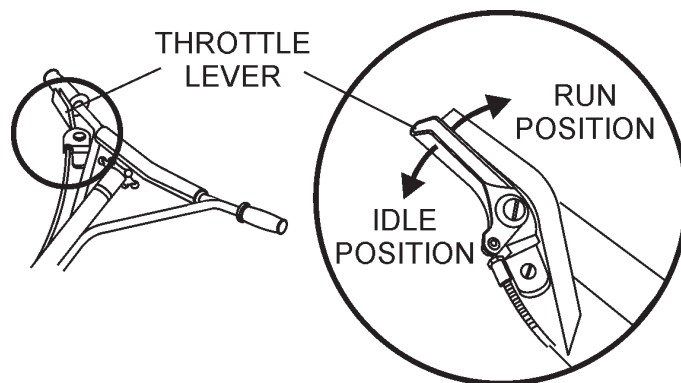

Figure 22. Throttle (Run Position)

SCT SERIES TROWEL — OPERATION

The following steps are intended as a basic guide to machine operation, and are not to be considered a complete guide to concrete finishing. We suggest that all operators, (experienced and novice), read "*Slabs on Grade*" published by the **American Concrete Institute, Detroit, Michigan**. Read the "Training" section of this manual for more information.

PITCHING THE BLADES

1. To pitch the blades upwards using the "**Standard**" handle, (Figure 23) simply turn the **star-wheel** clockwise. Turning the star wheel counter clockwise will cause the blades to lay flat.

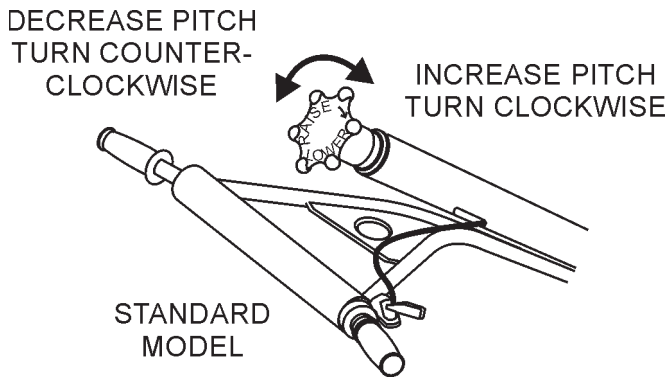

Figure 23. Pitching the Blades

Figure 24 below illustrates a typical walk-behind trowel application. Practice maneuvering the trowel. The trick is to let the trowel do the work.

Maneuvering the Trowel

1. With a secure foothold and a firm grasp on the handles slowly increase the engine speed until the desired blade speed is obtained.
2. To maneuver the trowel, gently lift up on or press down on the main trowel handle. To move the machine to the operator's left, **lift up** on the handle, to move machine to the right, **push down** on the handle.
3. The best method for finishing concrete is to slowly walk backwards (Figure 24) with the trowel, guiding the trowel from side to side. This will cover all footprints on wet concrete.
4. Remember that if you let go of the trowel, just step away and let the trowel come to a complete stop before trying to recover the trowel.
5. Continue to practice maneuvering the trowel. Try to practice as if you were finishing a slab of concrete. Practice edging and covering a large area.

WARNING



NEVER place your **feet** or **hands** inside the guard rings while starting or operating this equipment. **ALWAYS** keep clear of **rotating** or **moving** parts while operating this equipment.

To move the trowel to the operator's left, **lift up** on the handle, to move the trowel to the right **push down** on the handle.

Remember! that if you let go of the trowel, just **step away** and let the trowel come to a complete **STOP** before trying to recover the trowel.

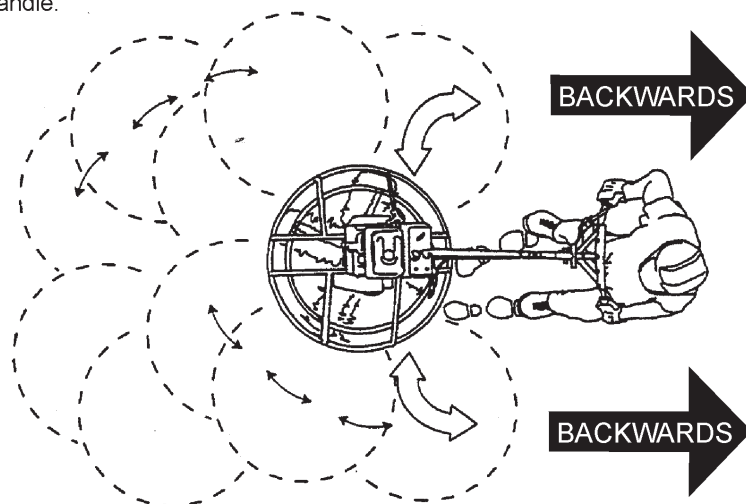

The best method for finishing concrete is to slowly walk **backwards** with the trowel, guiding the trowel from side to side. This will cover all footprints on wet concrete.

Figure 24. Maneuvering The Trowel

SCT SERIES TROWEL — OPTIONS

Blades

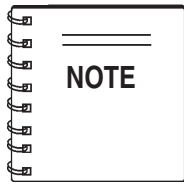

Blades should be changed when they fail to finish concrete in a satisfactory manner.

Blades are a vital part of finishing concrete. This trowel, or **finisher**, has been designed to finish concrete and the blades are built to stringent quality standards out of the finest trowel steel. If you need replacement blades, consult your parts list in this manual for part numbers and order them from your Multiquip parts dealer or importer.

Combo Blades

This trowel was equipped with combination **float/finish** (Figure 25) blades as original equipment. These blades have been designed for optimum performance in both the floating and finishing operations. These blades are versatile and should take care of most troweling needs.

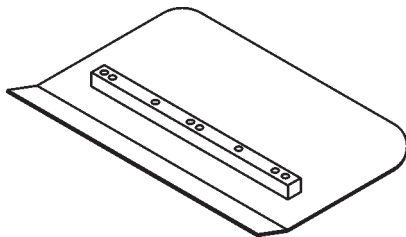

Figure 25. Combination Blade

Finish Blades (Optional)

These blades (Figure 26) have been specifically designed for finish operations with this trowel. They will provide a premium surface finishing capability from your trowel. They should only be used after the concrete has set to the point where the trowel does not sink into the concrete when placed on it.

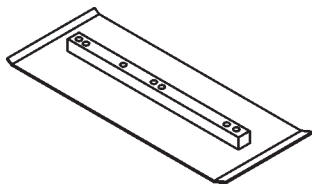

Figure 26. Finish Blade

Clip-On Float Blades (Optional)

These blades will clip on to an existing installed blade, (Figure 27), allowing the finisher to "float" on "wet" concrete so that the troweling operation can begin as early as possible. They can be easily removed, so when the concrete is sufficiently cured, the troweling operation can continue.

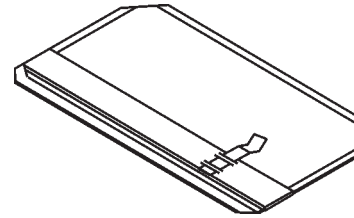

Figure 27. Clip-On Float Blade

Float Discs (Optional)

These round discs (Figure 28) attach to the spiders and allow the machine to "float" on "wet" concrete. The disc design allows early floating and easy movement from wet to dry areas. They are also very effective in embedding large aggregates and surface hardeners.

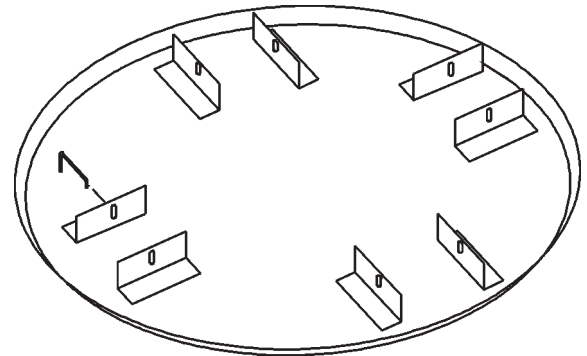

Figure 28. Float Disk

Trowel Arm Adjustment Tool

If blades show uneven wear patterns or some tend to wear out faster than others, the trowel arms may need to be adjusted. A special tool P/N 1817, (Figure 29) is available that can be used to adjust all of the trowel arms consistently.

See page 33 for Trowel Arm Adjustment procedures using this tool.

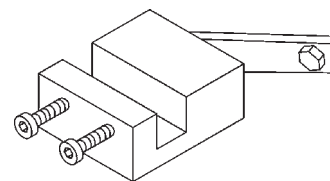

Figure 29. Trowel Arm Adjustment Fixture

SCT SERIES TROWEL — MAINTENANCE (ENGINE)

Engine Maintenance

Perform engine maintenance procedures as referenced by Table 5 below:

Table 5. Engine Maintenance Schedule							
DESCRIPTION (3)	OPERATION	BEFORE	FIRST MONTH OR 10 HRS.	EVERY 3 MONTHS OR 25 HRS.	EVERY 6 MONTHS OR 50 HRS.	EVERY YEAR OR 100 HRS.	EVERY 2 YEARS OR 200 HRS.
Engine Oil	CHECK	X					
	CHANGE		X				
Air Cleaner	CHECK	X					
	CHANGE			X (1)			
All Nuts & Bolts	Re-tighten If Necessary	X					
Spark Plug	CHECK-CLEAN				X		
	REPLACE						X
Cooling Fins	CHECK				X		
Spark Arrester	CLEAN					X	
Fuel Tank	CLEAN					X	
Fuel Filter	CHECK					X	
Idle Speed	CHECK-ADJUST					X (2)	
Valve Clearance	CHECK-ADJUST						X (2)
Fuel lines	CHECK	Every 2 years (replace if necessary) (2)					

(1) Service more frequently when used in **DUSTY** areas.

(2) These items should be serviced by your servic dealer, unless you have the proper tools and are mechanically proficient. Refer to the HONDA shop Manual for service procedures

(3) For commercial use, log hours of operation to determine proper maintenance intervals.

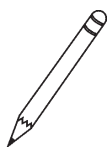
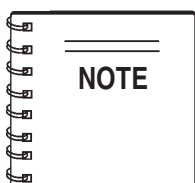

Reference manufacturer engine manual for specific servicing instructions.

SCT SERIES TROWEL — MAINTENANCE (ENGINE)

Maintenance

Perform the engine maintenance procedures as indicated below:

DAILY

- Thoroughly remove dirt and oil from the engine and control area. Clean or replace the air cleaner elements as necessary. Check and retighten all fasteners as necessary. Check the spring box and bellows for oil leaks. Repair or replace as needed.

WEEKLY

- Remove the fuel filter cap and clean the inside of the fuel tank.
- Remove or clean the filter at the bottom of the tank.
- Remove and clean the spark plug (Figure 30), then adjust the spark gap to 0.028 ~0.031 inch (0.6~0.7 mm). This unit has electronic ignition, which requires no adjustments.

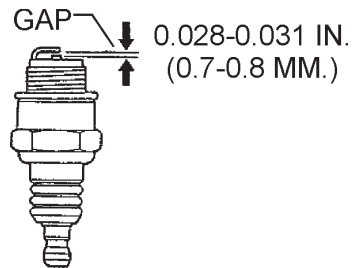

Figure 30. Spark Plug Gap

ENGINE OIL

- Drain the engine oil when the oil is **warm** as shown in Figure 31.
- Remove the oil drain bolt and sealing washer and allow the oil to drain into a suitable container.
- Replace engine oil with recommended type oil as listed in Table 4. **DO NOT** overfill. See Table 2 for oil capacity.
- Install drain bolt with sealing washer and tighten securely.

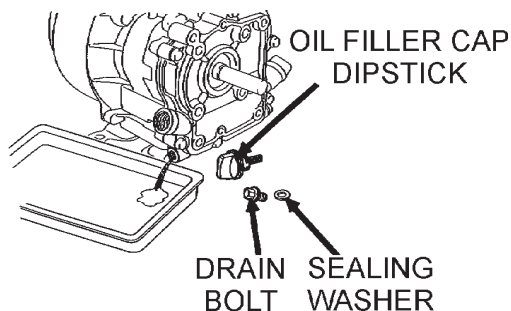
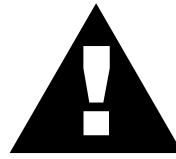

Figure 31. Engine Oil (Draining)

DANGER :



DO NOT use gasoline as a cleaning solvent, because that would create a risk of fire or explosion.

ENGINE AIR CLEANER

- Remove the air cleaner cover and foam filter element as shown in Figure 32.
- Tap the paper filter element (Figure 32) several times on a hard surface to remove dirt, or blow compressed air [not exceeding 30 psi (207 kPa, 2.1 kgf/cm²)] through the filter element from the air cleaner case side. **NEVER** brush off dirt. Brushing will force dirt into the fibers. Replace the paper filter element if it is excessively dirty.
- Clean foam element in warm, soapy water or nonflammable solvent. Rinse and dry thoroughly. Dip the element in clean engine oil and completely squeeze out the excess oil from the element before installing.

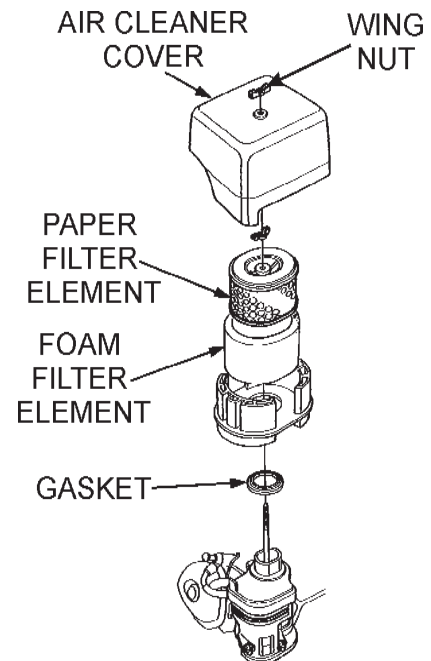
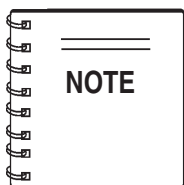

Figure 32. Engine Air Cleaner

SCT SERIES TROWEL — MAINTENANCE



See the engine manual supplied with your machine for appropriate engine maintenance schedule and troubleshooting guide for problems.

At the front of the book (Page 7) there is a "**Daily Pre-Operation Checklist**". Make copies of this checklist and use it on a daily basis.

CAUTION!



ALWAYS allow the engine to cool before servicing. **NEVER** attempt any maintenance work on a **hot!** engine.



MAINTENANCE SCHEDULE

Daily (8-10 Hours)

1. Check the oil level in the engine crankcase and gear box, fill as necessary.
2. Check V-belt.

Weekly (50-60 Hours)

1. Relube arms, thrust collar and clutch.
2. Replace blades if necessary.
3. Check and clean or replace the engine air filter as necessary.
4. Replace engine oil and filter as necessary, see engine manual.

Monthly (200-300 Hours)

1. Remove, clean, reinstall and relube the arms and thrust collar.
2. Adjust the blade arms.

Yearly (2000-2500 Hours)

1. Check and replace if necessary the arm bushings, thrust collar bushings and shaft seals.
2. Check pitch control cables for wear.
3. Adjust blade speed.

Trowel Arm Adjustment Procedure

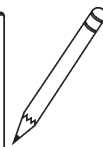
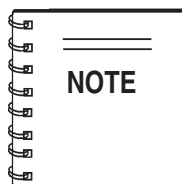

The following procedure should be followed to adjust trowel arms when it becomes apparent that the trowel is finishing poorly or in need of routine maintenance.

A **level**, clean area to test the trowel prior to and after is essential. Any unlevel **spots** in the floor or debris under the trowel blades will give an incorrect perception of adjustment. Ideally, a 5 x 5" three-quarter inch thick **flat** steel plate should be used for testing.

1. To determine which blades need adjustment, place the trowel in the test area (three-quarter inch thick plate) and look for the following conditions:
 - Pitch the blades as flat as possible and look at the **adjustment bolts**. They should all barely make contact with the **lower wear plate** on the spider. If you can see that one of them is not making contact, some adjustment will be necessary.
 - Is the machine wearing out blades unevenly (i.e. one blade is completely worn out while the others look new)?

Figure 33 below illustrates a "**worn spider bushings or bent trowel arms**". Check to see that adjustment bolt is barely touching (0.10" max. clearance) lower wear plate. All alignment bolts should be spaced the same distance from the lower wear plate.

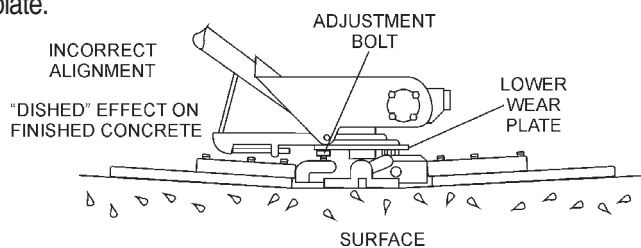

Figure 33. Worn Spider Plate

Figure 34 below illustrates the "**correct alignment**" for a spider plate (as shipped from the factory).

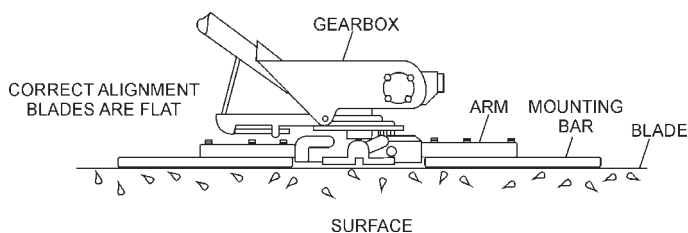

Figure 34. Correct Spider Plate Alignment

SCT SERIES TROWEL — MAINTENANCE

2. Start engine, and bring trowel blades up to full speed and look for the following conditions:
 - Does the trowel have a perceived rolling or bouncing motion when in use?
 - Look at the trowel while it is running, does the guard ring “rock up and down” relative to the ground?

Spider Removal

1. Once it is determined that an adjustment is required, remove the spider assembly from the gearbox shaft as follows:
 - a. Locate the cone point square head set screw (Figure 35) and attached jam nut found on the side of the spider assembly.

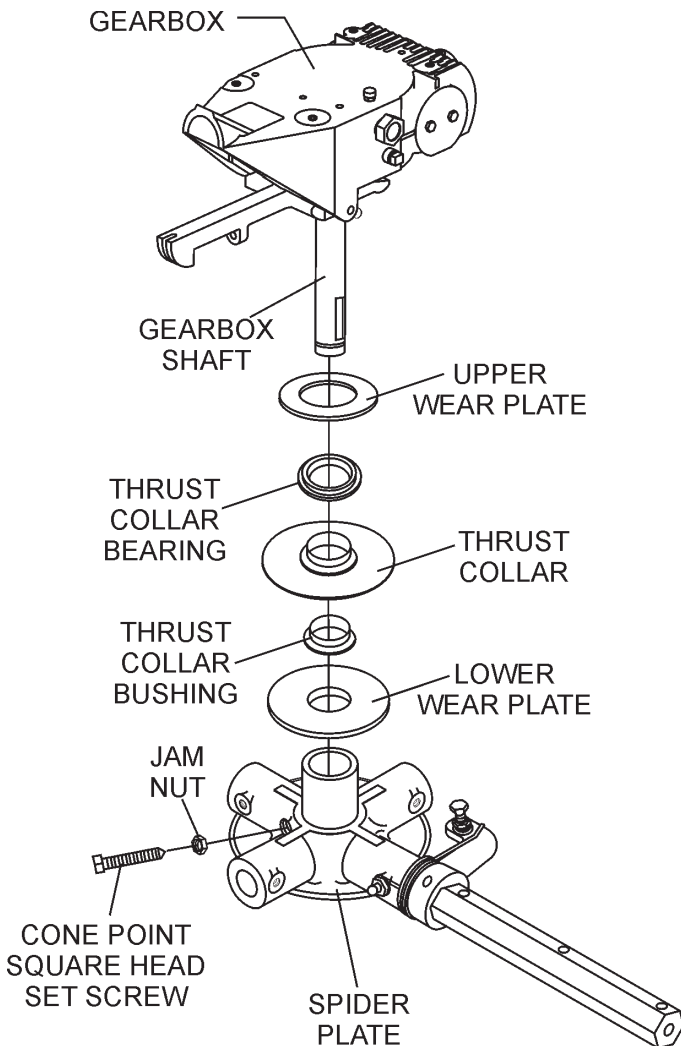

Figure 35. Spider/Gearbox Removal

- b. Loosen the jam nut and cone point square head set screw, and carefully lift the **upper trowel assembly** off of the spider assembly. A slight tap with a rubber mallet may be necessary to dislodge the spider from the main shaft of the gearbox.
 - c. If the trowel is equipped with an outer stabilizer ring (Figure 36), remove the four bolts at the end of each spider arm.

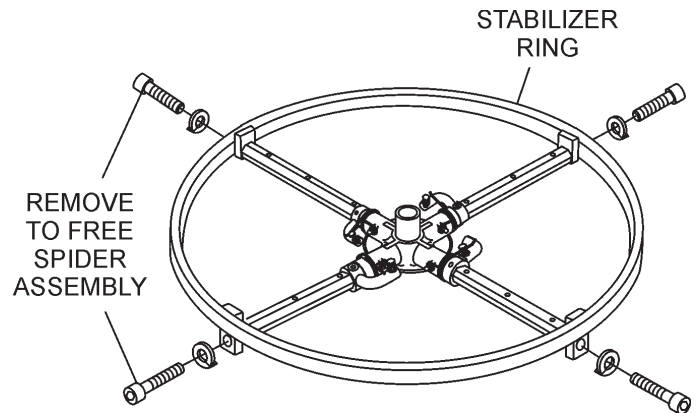

Figure 36. Stabilizer Ring

- d. Examine stabilizer ring for out of round or bends. If ring is damaged, replace ring. If ring is found to be correct with no damage, set aside.

Trowel Arm Removal

1. Each trowel arm is held in place at the spider plate by a hex head bolt (zerk grease fitting) and a roll pin. Remove both the hex head bolt and the roll pin (Figure 37) from the spider plate.
2. Remove the trowel arm from the spider plate.

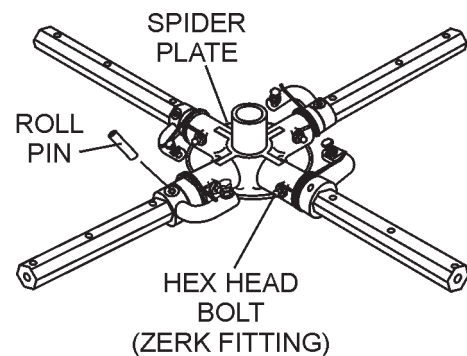

Figure 37. Removing Roll Pin and Zerk Grease Fitting

SCT SERIES TROWEL — MAINTENANCE

- Should the trowel arm inserts (bronze bushing) come out with the trowel arm, remove the bushing from the trowel arm and set aside in a safe place. If the bushing is retained inside the spider plate, carefully remove the bushing.
- Examine the bronze trowel arm bushing insert (Figure 38), and clean if necessary. Replace the bushing if out-of-round or worn.

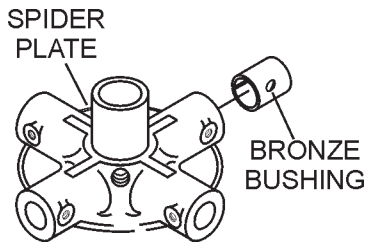

Figure 38. Bronze Bushings

Trowel Blade Removal

- Remove the trowel blades from the trowel arm by removing the hex head bolts (Figure 39) from the trowel arm. The 36" model will have two hex head bolts per arm and the 46" model will have three hex head bolts per arm. Set blades aside.

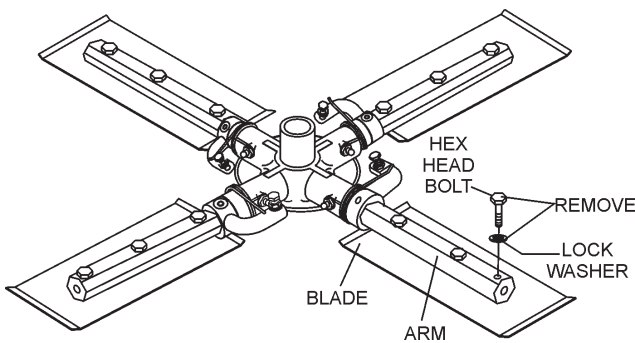

Figure 39. Trowel Blades

- Wire brush** any build-up of concrete from all six sides of the trowel arm. Repeat this for the remaining three arms.

Trowel Arm Flatness Test

- Using a piece of 3/4 inch thick steel plate or any surface which is **true** and **flat**, check all **six sides** of each trowel arm for flatness.
- Check each of the six sides of the trowel arm (hex section only) using a ten thousandths of an inch (max.) feeler gauge (Figure 40) between the flat of the trowel arm and an **extremely flat** test surface.

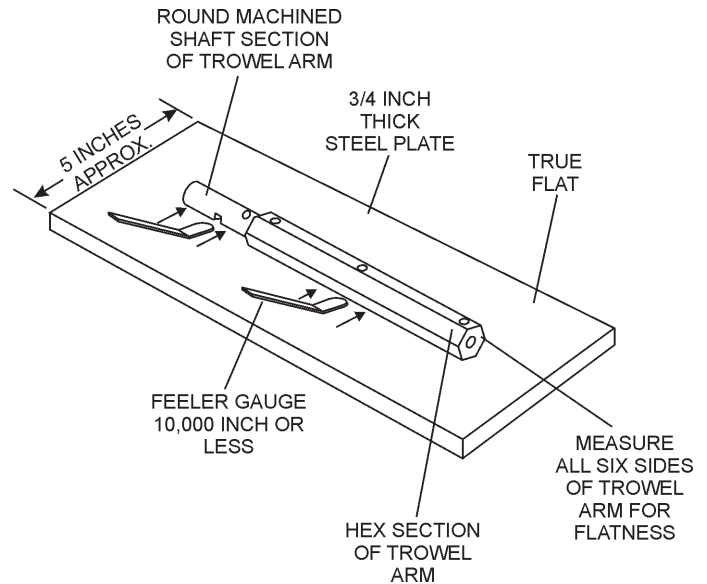
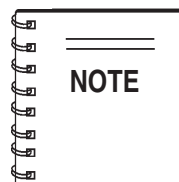

Figure 40. Trowel Arm Flatness Test

- If the trowel arm is found to be **uneven** or **bent**, replace the trowel arm. A bent trowel will not allow the trowel to operate in a smooth fluid rotation.
- Next, check each of the six sides of the round machined shaft section of the trowel arm. Each section should have the **same clearance** between the round of the trowel arm shaft and the test surface.



Trowel arms can be damaged by rough handling or by striking exposed plumbing or forms while in operation. **ALWAYS** look-out for objects which might cause damage to the trowel arms.

SCT SERIES TROWEL — MAINTENANCE

Trowel Arm Adjustment

Shown in Figure 41 is the adjustment fixture with a trowel arm inserted. As each trowel arm is locked into the fixture, the arm bolt is adjusted to where it contacts a stop on the fixture. This will consistently adjust all of the trowel arms, keeping the finisher as flat and evenly pitched as possible.

1. Locate the trowel arm adjustment tool P/N 1817. Set the adjustment tool for a clock-wise blade rotation, meaning the fixture arm is in the "UP" position.

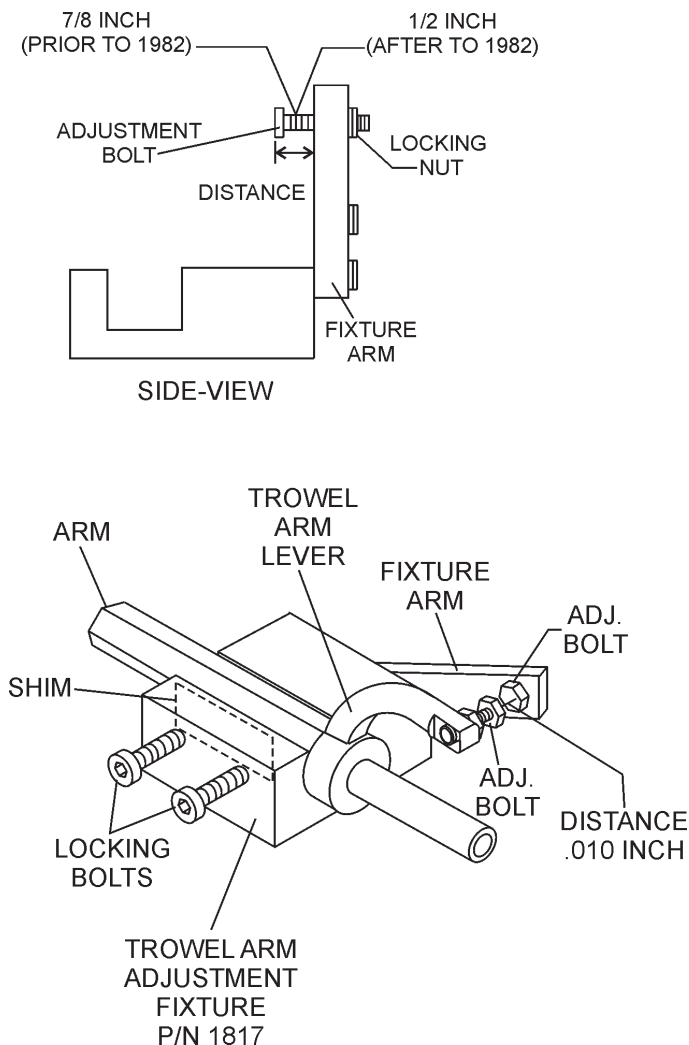

Figure 41. Trowel Arm Adjustment Tool

2. Un-screw the locking bolts on the adjustment tool, and place the trowel arm into the adjustment fixture channel as shown in Figure 43. A *thin shim* may be required to cover the blade holes on the trowel arm. Make sure to align the trowel adjustment bolt with the fixture adjustment bolt.
3. Using an allen wrench, tighten the locking bolts on the adjustment tool and securely lock the trowel arm in place.

4. Loosen the locking nut on the trowel arm lever, then turn the trowel arm adjusting bolt until it barely touches (.010") the adjusting bolt on the fixture.
5. After the correct adjustment has been made, tighten lock nut on trowel arm lever to lock in place.
6. Loosen locking bolts on adjustment fixture, and remove trowel arm from fixture.
7. Repeat steps 2-7 for the remaining trowel arms.

Re-Assembly

1. Clean and examine the upper/lower wear plates and thrust collar. Examine the entire spider assembly. Wire brush any concrete or rust build-up. If any of the spider components are found to be damaged or out of round, replace them.
2. Make sure that the bronze trowel arm bushing is not damage or out of round. Clean the bushing if necessary. If the bronze bushing is damage or worn, replace it.
3. Reinstall bronze bushing onto trowel arm.
4. Repeat steps 2 -3 for each trowel arm.
5. Make sure that the spring tensioner is in the correct position to exert tension on the trowel arm.
6. Insert all trowel arms with levers into spider plate (with bronze bushing already installed) using care to align grease hole on bronze bushing with grease hole fitting on spider plate.
7. Lock trowel arms in place by tightening the hex head zerk grease fitting and jam nut.
8. Re-install the blades back onto the trowel arms.
9. Install stabilizer ring onto spider assembly.
10. Reinstall **lower wear plate, thrust collar and upper wear ring** in the **reverse order** that they were dis-assembled onto the spider shaft. Make sure that there is little or no lateral movement between the thrust collar and the spider shaft.
11. Carefully lift **the upper trowel assembly**, line up the key-way on gear box main shaft and insert into spider assembly.
12. Reinstall square head cone point into spider plate and tighten in place. Tighten jam nut. Use care in making sure point of set screw engages groove in gear box main shaft.
13. Lubricate all grease points (zerk fittings) with premium "**Lithum 12**" based grease, conforming to NLG1 Grade #2 consistency.

SCT SERIES TROWEL — MAINTENANCE

Testing

1. Place trowel in test area, start engine and test trowel for smoothness.
2. If trowel bounces has excessive vibration or does not run smoothly repeat alignment procedure.

Changing a Blade

It is recommended that ***all the blades be changed at the same time***. The machine may wobble or bounce if only some of the blades are changed at one time.

1. Place the machine on a flat, level surface. Adjust the blade pitch control to make the blades as flat as possible. Note the blade orientation on the trowel arm.



Before removing the blades, please note the orientation of the blade on the trowel arm

1. Remove the three bolts and lock washers that secure the blade to the trowel arm. Remove the blade.
2. Using a wire brush, scrape all concrete particles and foreign debris from the trowel arm.
3. Install the new trowel blade onto the trowel arm. Make sure blade is installed correctly, maintaining the proper orientation for direction of rotation.
4. Reinstall the three bolts and lock washers that secure the blade to the trowel arm. Tighten all three bolts securely.
5. Repeat steps 1-4 for all remaining blades.

V-Belt Inspection and Replacement

Inspect the v-belt for wear, fraying and deterioration. Replace with the appropriate size belt as follows:

5.5 HP Models: P/N 01390

8 HP Models: P/N 01243

11 HP Models: P/N 01523

To remove and replace the v-belt:

1. Remove the belt guard by removing the 3 hex head screws, star washers and flat washers.
2. Slip the belt up and over the top of the clutch assembly.
3. Install the new belt and re-install the belt guard. (No adjustment is necessary on the v-belt.)

SCT SERIES TROWEL — TROUBLESHOOTING (TROWEL)

TABLE 6. TROWEL TROUBLESHOOTING

SYMPTOM	POSSIBLE PROBLEM	SOLUTION
Engine running rough or not at all.	Safety Stop Switch malfunction?	Make sure that the Safety Stop Switch is ON or replace switch if necessary.
	Fuel?	Look at the fuel system. Make sure there is fuel being supplied to the engine. Check to ensure that the fuel filter is not clogged.
	Ignition?	Check to ensure that the ignition switch has power and is functioning correctly.
Safety Stop Switch not functioning.	Other problems?	Consult engine manufacturer's manual.
	Loose wire connections?	Check wiring. Replace as necessary.
	Bad contacts?	Replace switch.
If trowel "bounces, rolls concrete, or makes uneven swirls in concrete".	Blades?	Make certain blades are in good condition, not excessively worn. Finish blades should measure no less than 2" (50mm) from the blade bar to the trailing edge, combo blades should measure no less than 3.5" (89mm). Trailing edge of blade should be straight and parallel to the blade bar.
	Spider?	Check that all blades are set at the same pitch angle as measured at the spider. A field adjustment tool is available for height adjustment of the trowel arms (see Optional Equipment).
	Bent trowel arms?	Check the spider assembly for bent trowel arms. If one of the arms is even slightly bent, replace it immediately.
	Trowel arm bushings?	Check the trowel arm bushings for tightness. This can be done by moving the trowel arms up and down. If there is more than 1/8" (3.2 mm) of travel at the tip of the arm, the bushings should be replaced. All bushings should be replaced at the same time.
	Thrust collar?	Check the flatness of the thrust collar by rotating it on the spider. If it varies by more than 0.02" (0.5 mm) replace the thrust collar.
	Thrust collar bushing?	Check the thrust collar by rocking it on the spider. If it can tilt more than 3/32" (2.4 mm) [as measured at the thrust collar O.D.], replace the bushing in the thrust collar.
	Thrust bearing worn?	Check the thrust bearing to see that it is spinning free. Note: Thrust cap, replace if necessary.
Machine has a perceptible rolling motion while running.	Main shaft?	The main output shaft of the gearbox assembly should be checked for straightness. The main shaft must run straight and cannot be more than 0.003" (0.08 mm) out of round at the spider attachment point.
	Yoke?	Check to make sure that both fingers of the yoke press evenly on the wear cap. Replace yoke as necessary.
	Blade Pitch?	Check to ensure that each blade is adjusted to have the same pitch as all other blades. Adjust per maintenance section in manual.

SCT SERIES TROWEL — TROUBLESHOOTING (TROWEL)

TABLE 6. TROWEL TROUBLESHOOTING (CONTINUED)

SYMPTOM	POSSIBLE PROBLEM	SOLUTION
Sluggish response to engine speed change.	Worn V-belts?	Replace V-belt.
	Dirty centrifugal clutch?	Disassemble and clean clutch.
	Defective or worn out centrifugal clutch?	Replace entire clutch.
	Worn bearings in gearbox?	Rotate input shaft by hand. If shaft rotates with difficulty, check the input and output shaft bearings. Replace as necessary.
	Worn or broken gears in gearbox?	Verify that the gearbox shaft rotates when the input shaft is rotated. Replace both the worm and worm gear as a set.

TABLE 7. ENGINE TROUBLESHOOTING

SYMPTOM	POSSIBLE PROBLEM	SOLUTION
Operation not satisfactory		
Rotational speed fluctuates.	Governor adjustment improper?	Adjust governor to correct lever.
	Governor spring defective?	Clean or replace ignition.
	Fuel flow erratic?	Check fuel line.
	Air taken in through suction line?	Check suction line.
Recoil starter not working properly.	Dust in rotating part?	Clean recoil starter assembly.
	Spring spring failure?	Replace sprial spring.

SCT SERIES TROWEL — TROUBLESHOOTING (ENGINE)

TABLE 7. ENGINE TROUBLESHOOTING (CONTINUED)

SYMPTOM	POSSIBLE PROBLEM	SOLUTION
Difficult to start		
Fuel is available but spark plug will not ignite. (Power available at high tension cable).	Ignition plug being bridge?	Check ignition system.
	Carbon deposit at ignition?	Clean or replace ignition.
	Short circuit due to defective insulators?	Replace insulators.
	Improper spark gap?	Set spark plug gap to the correct gap.
Fuel is available but spark plug will not ignite. (Power NOT available at high tension cable).	Short circuit at stop switch?	Check stop switch circuit. Replace stop switch if defective.
	Ignition coil defective?	Replace ignition coil.
Fuel is available and spark plug ignites (compression normal).	Muffler clogged with carbon deposits?	Clean or replace muffler.
	Fuel in use inadequate (water, dust)?	Flush fuel sytem and replace with fresh fuel.
	Air Cleaner clogged?	Clean or replace air cleaner.
Fuel is available and spark plug ignites (compression low).	Defective cylinder head gasket?	Tighten cylinder head bolts or replace head gasket.
	Cylinder worn?	Replace cylinder.
	Spark plug loose?	Tighen spark plug.
Operation not satisfactory		
Not enough power available (compression normal, no miss-firing).	Air cleaner clogged?	
	Air in fuel line?	Bleed (remove air) from fuel line.
	Fuel level in carbureator float chamber improper?	Adjust carbureator float
	Carbon deposits in cylinder?	Clean or replace cylinder
Not enough power available (compression normal, miss-firing).	Ignition coil defective?	Flush fuel sytem and replace with fresh fuel.
	Ignition plug often shorts?	Replace ignition wires, clean ignition.
	Fuel in use inadequate (water, dust)?	Flush fuel sytem and replace with fresh fuel.
Engine overheats.	Excessive carbon depostion in combustion chamber?	Clean or replace crankcase.
	Exhaust or muffler clogged with carbon.	Clean or replace muffler.
	Spark plug heat value incorrect?	Replace spark plug with correct type spark plug.

SCT SERIESTROWEL — EXPLANATION OF CODES IN REMARKS

How to read the marks and remarks used in this parts book.

Section 1: Items Found In the “Remarks” Column

Serial Numbers-Where indicated, this indicates a serial number range (inclusive) where a particular part is used.

Model Number-Where indicated, this shows that the corresponding part is utilized only with this specific model number or model number variant.

Section 2: Items Found In the “Remarks” Column

Serial Numbers-Where indicated, this indicates a serial number range (inclusive) where a particular part is used.

Model Number-Where indicated, this shows that the corresponding part is utilized only with this specific model number or model number variant.

Section 3: Items Found In the “Items Number” Column

All parts with same symbol in the number column, *, #, +, %, or ■, belong to the same assembly or kit.

Note: If more than one of the same reference number is listed, the last one listed indicates newest (or latest) parts available.

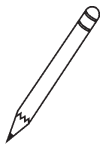

The contents of this parts catalog are subject to change without notice.

SCT SERIES TROWEL — SUGGESTED SPARE PARTS

SCT SERIESTROWEL 1 TO 3 UNITS

1 to 3 Units

Qty.....	P/N	Description
3	20478	GRIP
2	20856	SAFETY SWITCH
1	20285	PITCH CONTROL CABLE
1	20514	SAFETY STOP WIRE
1	30033-401	THROTTLE CABLE
4	1157 A	BUSHING
4	2828	ARM (11-3/4")
4	1162 A	LUBE CAP
4	12097	SCREW
4	1456	NUT
4	1875	WASHER
4	1322	SCREW
1	21046	GASKET KIT
1	21047	BEARING KIT
1	1247	RUBBER GROMMET
1	1245	SPACER
1	10968	THRUST COLLAR KIT
2	1390	BELT, A26 5.5 HP HONDA GX160QX2
3	0152-3	BELT, A28, 8.0 & 11.0 HP HAONDA

HONDA ENGINES

Qty.....	P/N	Description
3	17210ZE1505	AIR FILTER ELEMENT (GX160QX2)
3	17210ZE2505	AIR FILTER ELEMENT (GX240K1QA2)
3	17210ZE3505	AIR FILTER ELEMENT (GX340K1QAP2)
6	9807955846	SPARK PLUG, BPR5ES, NGK
1	36100ZH7003	SWITCH ASSEMBLY, ENG. STOP
1	17620ZH7023	TANK CAP, FUEL FILLER
1	34150ZH7003	OIL ALERT UNIT
1	28462ZH8003	ROPE RECOIL GX160QX2
1	28462ZE2W11	ROPE RECOIL GX240K1QA2
1	28462ZV7003	ROPE RECOIL GX340K1QAP2

SCT SERIES TROWEL — DECAL LOCATOR

NAMEPLATES AND DECALS

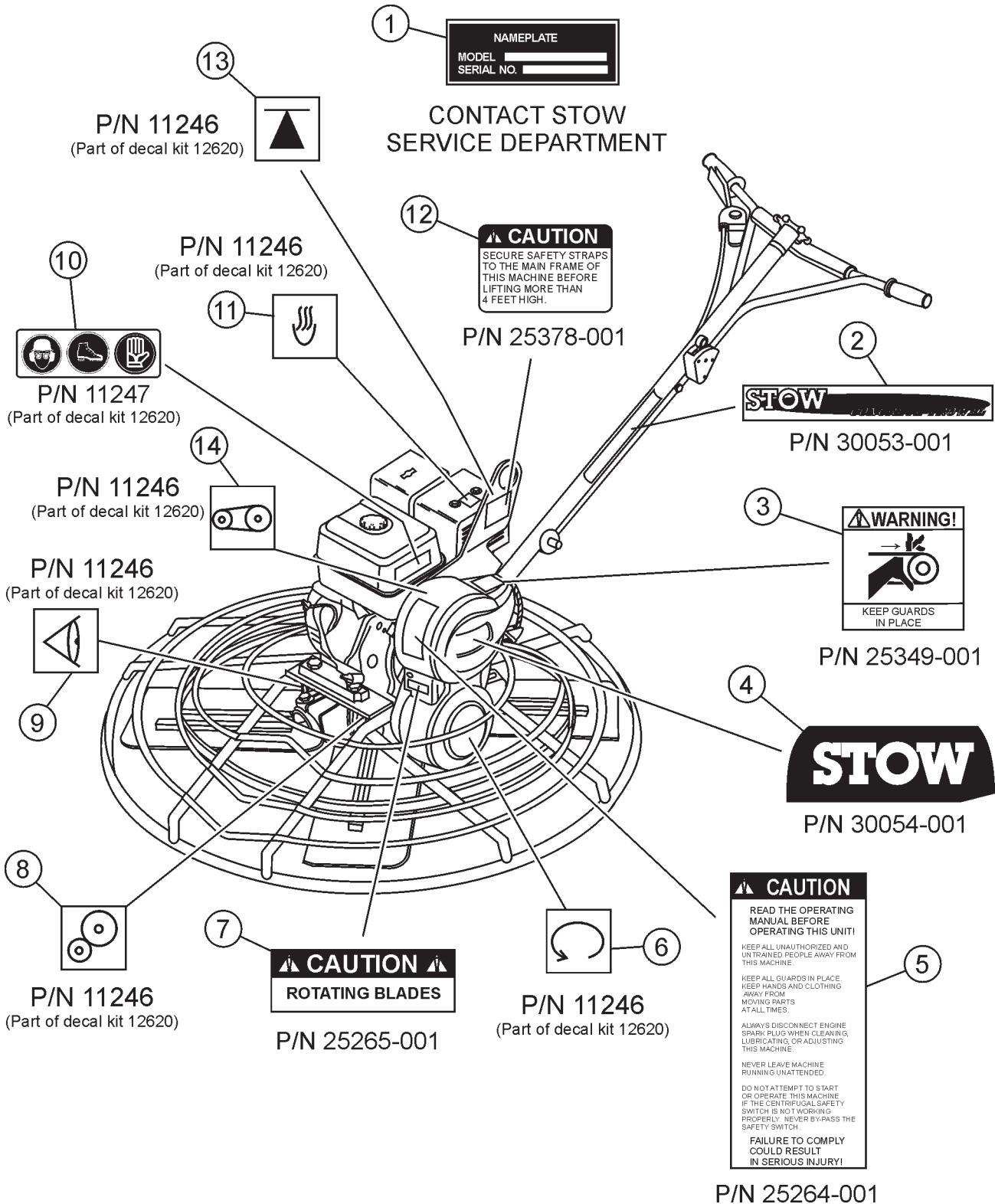

SCT SERIES TROWEL — DECAL LOCATOR

NAMEPLATE AND DECALS

<u>NO.</u>	<u>PART NO.</u>	<u>PART NAME</u>	<u>QTY.</u>	<u>REMARKS</u>
1		NAMEPLATE	1	CONTACT MULTQUIP PARTS DEPT.
2	30053-001	DECAL: SCT SERIES CONCRETE TROWEL	2	
3	25349-001	DECAL: WARNING, GUARDS	1	
4	30054-001	DECAL: STOW	1	
5	25264-001	DECAL: CAUTION, OPERATING INSTR.	1	
6	11246	DECAL: ROTATION	1	PART OF DECAL KIT P/N 12620
7	25265-001	DECAL: CAUTION, ROTATING BLADES	1	
8	11246	DECAL: GEAR DRIVE	1	PART OF DECAL KIT P/N 12620
9	11246	DECAL: OIL CHECK	1	PART OF DECAL KIT P/N 12620
10	11247	DECAL: HELMET, FOOT AND GLOVE	1	PART OF DECAL KIT P/N 12620
11	11246	DECAL: HOT	1	PART OF DECAL KIT P/N 12620
12	25378-001	DECAL: CAUTION, SAFETY STRAPS	1	
13	11246	DECAL: LIFTING POINT	1	PART OF DECAL KIT P/N 12620
14	11246	DECAL: BELT DRIVE	1	PART OF DECAL KIT P/N 12620

SCT SERIESTROWEL — STANDARD HANDLE

STANDARD HANDLE

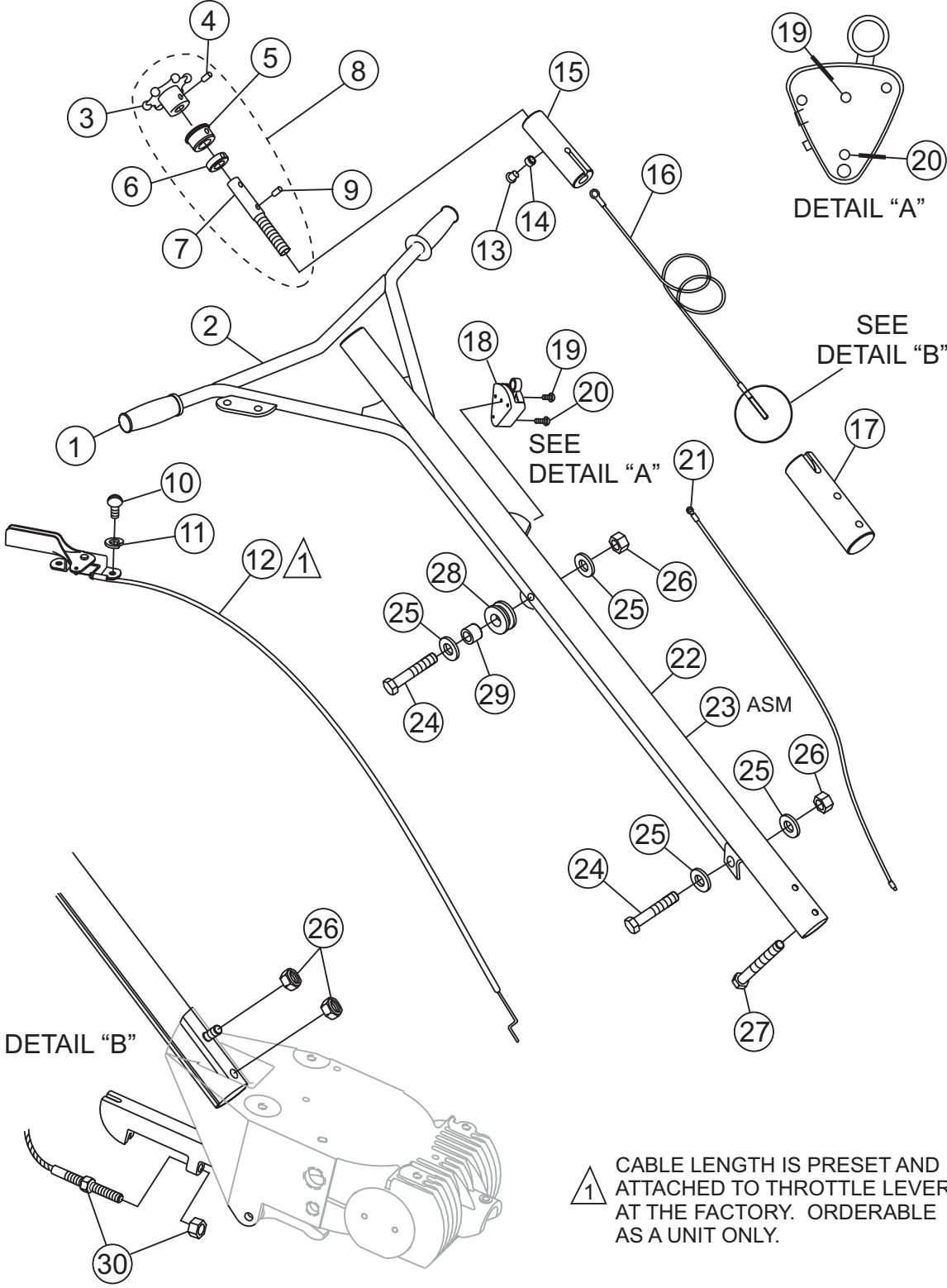

SCT SERIESTROWEL — STANDARD HANDLE

STANDARD HANDLE

<u>NO.</u>	<u>PART NO.</u>	<u>PART NAME</u>	<u>QTY.</u>	<u>REMARKS</u>
1	20478	GRIP, HANDLE	2	
2	21251	HANDLE	1	
3*	30115-001	HAND WHEEL, PITCH CONTROL	1	
4*	1729	PIN, ROLL 3/16 X 1-1/4	1	
5*	21248	BEARING, TROWEL CONTROL	1	
6*	3615	COLLAR, SET 3/4 ID	1	
7*	21282	SHAFT, PITCH CONTROL	1	
8*	21279	HAND WHEEL ASSEMBLY, PITCH CONTROL.....	1	INCLUDES ITEMS W/*
9*	0122C	SCREW, SHS 3/8-16 X 1/2	1	
10	06827-006	SCREW, RHM 10-32 X 3/8	2	
11	10019	NUT, NYLOC 10-32	2	
12	30033-401	LEVER, THROTTLE ASSEMBLY	1	
13	0786	SCREW, BHC 1/4- 20 X 3/8 NYL PATCH, NP	1	
14	0786A	SPACER, .360 X 17/64 X 1/8L	1	
15	21249	SLIDE BLOCK, TROWEL CONTROL	1	
16	20285	CABLE, PITCH CONTROL	1	
17	21250	BLOCK SUPPORT	1	
18	20856	SWITCH ASSEMBLY, SAFETY STOP	1	
19#	1602	SCREW, RHM 10-24 X 3/8.....	1	INCLUDES ITEMS W/#
20#	20988	SCREW, FHSC PHILLIPS 8-32 X 1 1/4	1	
21	20514	WIRE ASSEMBLY, SAFETY STOP SWITCH	1	
22	21254	HANDLE TUBE	1	
23	21150	HANDLE ASSEMBLY	1	
24	0169	SCREW, HHC 3/8-16 X 3.0	2	
25	10136	WASHER, FLAT 3/8 SAE	4	
26	10133	NUT, NYLOC 3/8-16	4	
27	1493	SCREW, HHC 3/8-16 X 3 1/4	1	
28	1247	GROMMET, 1/4 X .875ID X 1-5/8OD	1	
29	1245	BUSHING	1	
30	1116	NUT, BRASS JAM 5/16-18	2	

SCT SERIES TROWEL — 4-BLADE SPIDER ASSY.

4 BLADE SPIDER ASSY.

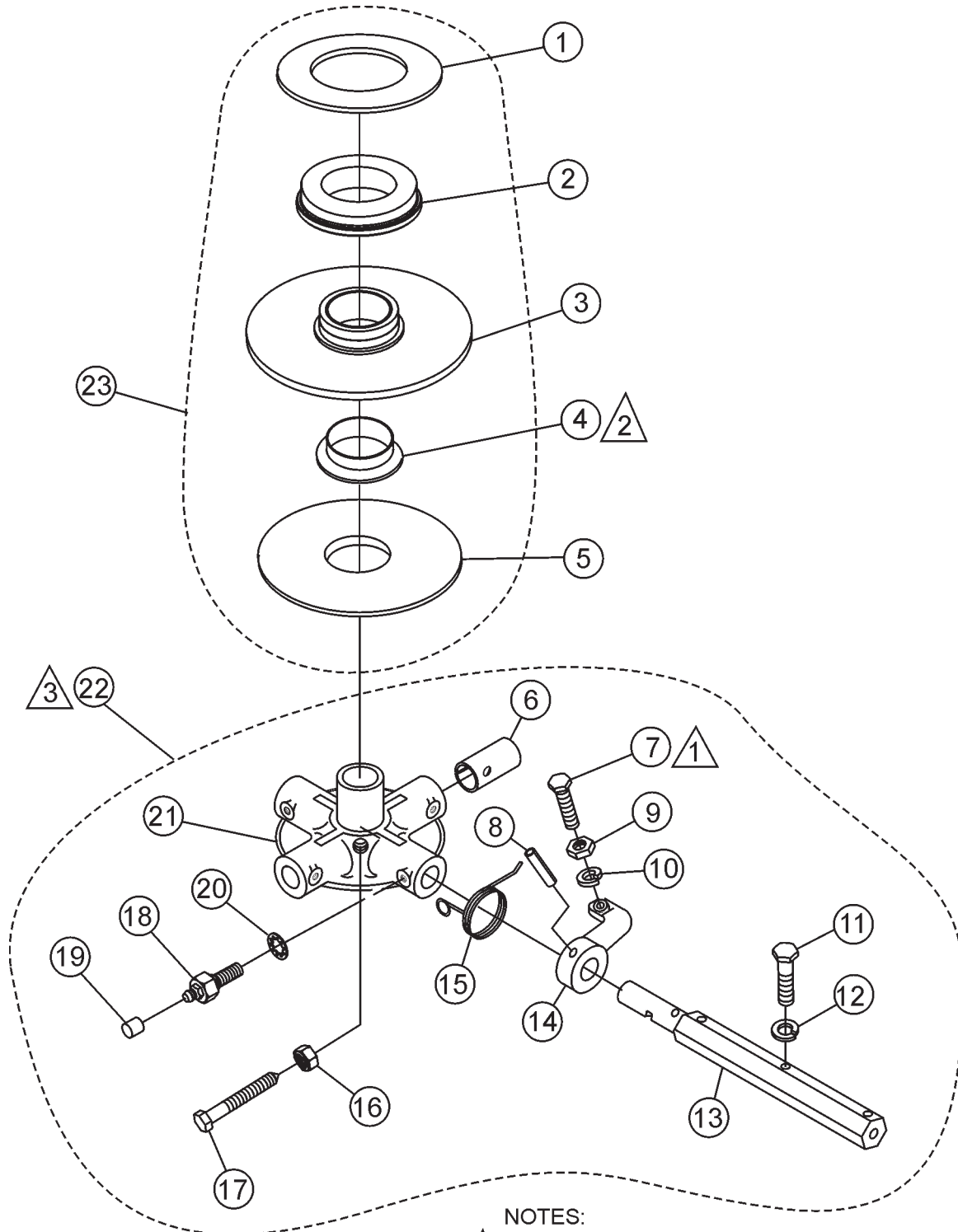

NOTES:

① APPLY LOCTITE P/N 1477

② INCLUDED WITH ITEM 3 OR CAN BE ORDERED SEPARATELY (P/N 1471).

③ SPIDER ASSEMBLY P/N 1215 INCLUDES ALL ITEMS WITHIN OUTLINE.

SCT SERIES TROWEL — 4-BLADE SPIDER ASSY.

4 BLADE SPIDER ASSY.

<u>NO.</u>	<u>PART NO.</u>	<u>PART NAME</u>	<u>QTY.</u>	<u>REMARKS</u>
1*	12208	WEAR RING	1	
2*	12778	FLANGE BEARING	1	
3*	10793	THRUST COLLAR	1	INCLUDES ITEMS W/#
4*#	1471	THRUST COLLAR BUSHING	1	
5*	1154A	WEAR PLATE	1	
6%	1157A	BEARING INSERT	4	
7%	0164B	RADIUS HEAD 3/8- 16 x 1-1/4"	4	
8%	4164	ROLL PIN 5/16 x 1-3/4"	4	
9%	1876	JAM NUT 3/8- 16	4	
10%	0166A	LOCK WASHER 3/8"	4	
11%	0105	SCREW, HHCS 5/16-18 X 1-1/2	8	36" MODELS
11%	0105	SCREW, HHCS 5/16-18 X 1-1/2	12	46" MODELS
12%	0161C	WASHER, LOCK 5/16	8	36" MODELS
12%	0161C	WASHER, LOCK 5/16	12	46" MODELS
13%	2828	TROWEL ARM 11-3/4	4	
14%	1163	TROWEL ARM LEVER	4	
15%	1316	SPRING (RIGHT HAND)	4	
16%	1456	HEX NUT 3/8-16	1	
17%	12097	SCREW, SQHS 3/8-16 x 1-3/4" CONE POINT	1	
18%	1322	RETAINING SCREW ASSY.	4	
19%	1162A	CAP, GREASE ZERK	4	
20%	1875	INT. SHKP. WASHER 3/8"	4	
21%	1161	SPIDER PLATE ONLY	1	
22	21261	SPIDER PLATE ASSEMBLY	1	INCLUDES ITEMS W/%
23	10968	THRUST COLLAR KIT	1	INCLUDES ITEMS W/*

SCT SERIES TROWEL — GEARBOX ASSY.

GEARBOX ASSY.

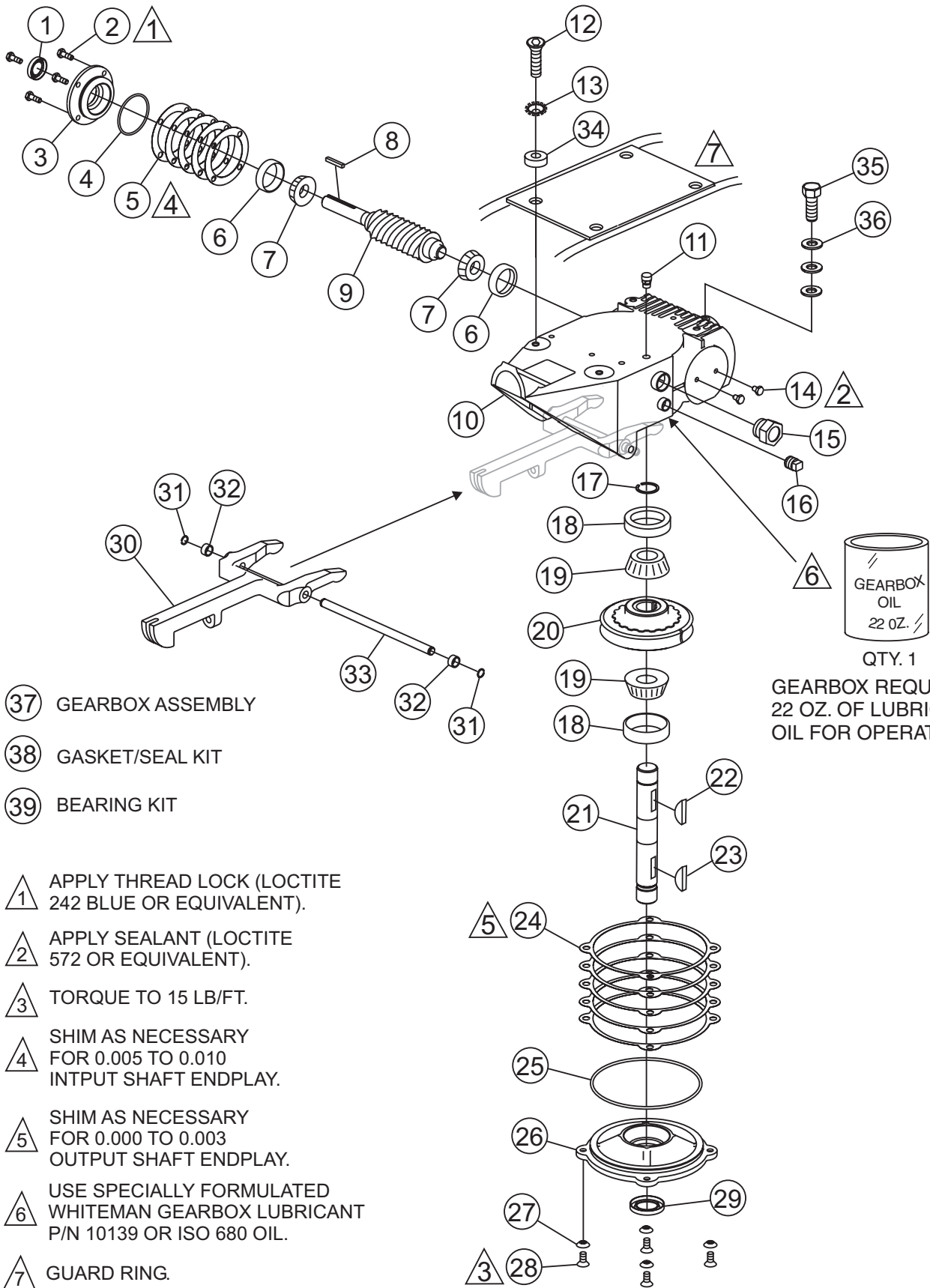

- 37** GEARBOX ASSEMBLY
- 38** GASKET/SEAL KIT
- 39** BEARING KIT

- 1** APPLY THREAD LOCK (LOCTITE 242 BLUE OR EQUIVALENT).
- 2** APPLY SEALANT (LOCTITE 572 OR EQUIVALENT).
- 3** TORQUE TO 15 LB/FT.
- 4** SHIM AS NECESSARY FOR 0.005 TO 0.010 INPUT SHAFT ENDPLAY.
- 5** SHIM AS NECESSARY FOR 0.000 TO 0.003 OUTPUT SHAFT ENDPLAY.
- 6** USE SPECIALLY FORMULATED WHITEMAN GEARBOX LUBRICANT P/N 10139 OR ISO 680 OIL.
- 7** GUARD RING.

QTY. 1
 GEARBOX REQUIRES
 22 OZ. OF LUBRICATING
 OIL FOR OPERATION.

SCT SERIES TROWEL — GEARBOX ASSY.

GEARBOX ASSY.

<u>NO.</u>	<u>PART NO.</u>	<u>PART NAME</u>	<u>QTY.</u>	<u>REMARKS</u>
1%*	0753	SEAL, OIL NATIONAL #470954	1	
2%	0131A	SCREW, HHC 1/4-20 X 3/4	4	
3%	12876	FLANGE, INPUT SHAFT	1	
4%*	20395	RING, O -139 BUNA N	1	
5%*	20397	SHIM, INPUT 0.002 THICK	1	
	20398	SHIM, INPUT 0.003 THICK	1	
	20399	SHIM, INPUT 0.005 THICK	1	
	20400	SHIM, INPUT 0.010 THICK	1	
	20401	SHIM, INPUT 0.020 THICK	1	
6%#	20466	BEARING, CUP, TIMKEN #LM11910	2	
7%#	20465	BEARING, CONE, TIMKEN #LM11949	2	
8%	0627	KEY, SQUARE 3/16 X 1 1/4	1	
9%	1851	GEAR, WORM & SHAFT ASSY.	1	
10%	12874	CASE, GEAR	1	
11%	21218	VENT, AIR	1	
12	1394	SCREW, FHSC 3/8 - 16 X 1	4	
13	1480	WASHER, C/S EXT. SHKP, 3/8	4	
14%	20476	SCREW, HHC 1/4-28 X 3/8	2	
15%	21033	SIGHT GLASS, 3/4 M PIPE STEEL	1	
16%	0121A	FITTING, PLUG 3/8 MP SQ HEAD	1	
17%	1138	RING, SNAP, TRUARC 5100-112	1	
18%#	20475	BEARING, CUP TIMKEN #M86610	2	
19%#	20474	BEARING, CONE TIMKEN #M86647	2	
20%	1140	GEAR, WORM, BRONZE	1	
21%	20470	SHAFT, OUTPUT	1	
22%	1139	KEY, WOODRUFF #21 HARDENED	1	
23	1238	KEY, WOODRUFF #25	1	
24%*	20402	SHIM, OUTPUT 0.002 THICK	1	
	20403	SHIM, OUTPUT 0.003 THICK	1	
	20404	SHIM, OUTPUT 0.005 THICK	1	
	20405	SHIM, OUTPUT 0.010 THICK	1	
	20406	SHIM, OUTPUT 0.020 THICK	1	
25%*	20396	RING, O -257 BUNA N	1	
26%	12875	COVER, GEARBOX	1	
27%	10235	WASHER, C/S EXT. SHKP	4	
28%	1146	SCREW, FHSC 5/16-18 X 1, NYLOC NP	4	
29%*	0254	SEAL, OIL, NATIONAL #470712	1	
30	1150	ARM, YOKE	1	
31	20802	RING, SNAP, TRUARC 5100-37 OR EQUIV.	2	
32	20803	SPACER, .50 OD X .40 ID X 0.25L	2	
33	20801	PIN, YOKE	1	
34	16045	SPACER, GEARBOX	4	
35	0655	SCREW, HHC 5/16-18 X 3/4	1	
36	0300B	WASHER, FLAT 5/16 SAE	3	
37	21219	GEARBOX ASSY.	1	INCLUDES ITEMS W/%
38	21046	GASKET SEAL KIT	1	INCLUDES ITEMS W/*
39	21047	BEARING KIT	1	INCLUDES ITEMS W/#

SCT SERIESTROWEL — GUARD RING ASSY.

GUARD RING ASSY.

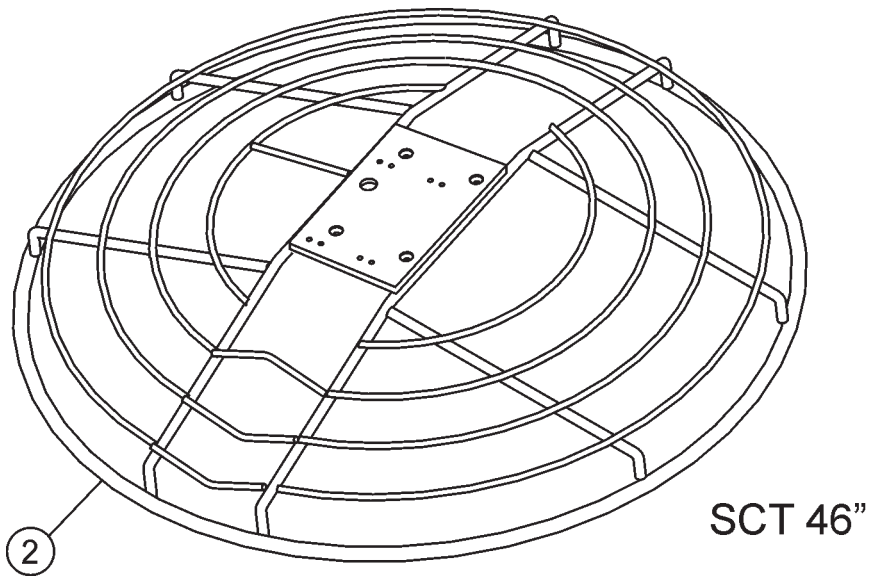
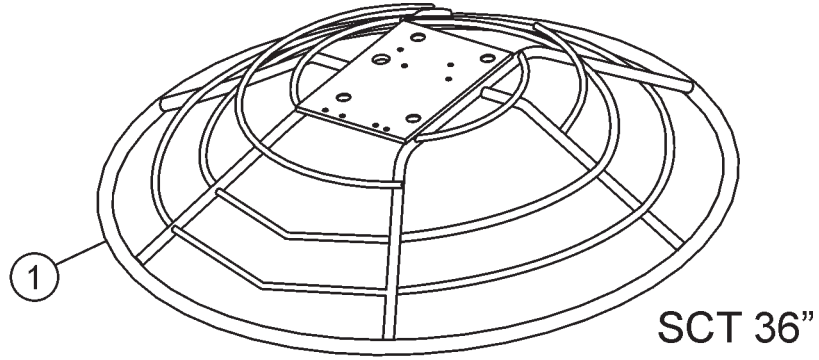

SCT SERIESTROWEL — GUARD RING ASSY.

GUARD RING ASSY.

<u>NO.</u>	<u>PART NO.</u>	<u>PART NAME</u>	<u>QTY.</u>	<u>REMARKS</u>
1	21119	RING, STATIONARY GUARD, 36"	1	
2	21122	RING, STATIONARY GUARD, 46"	1	

SCT SERIESTROWEL — STABILIZER RING ASSY.

STABILIZER RING ASSY.

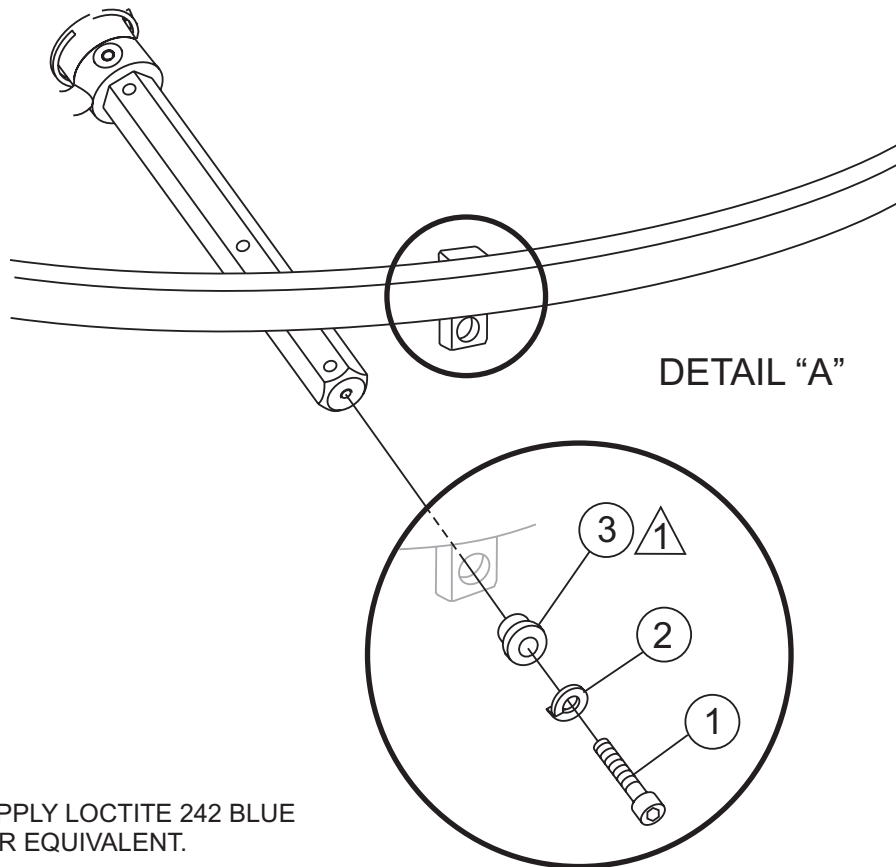
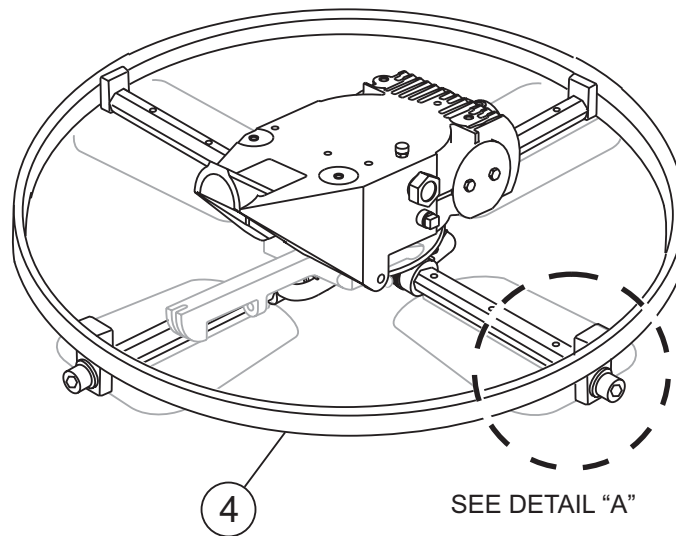

1 APPLY LOCTITE 242 BLUE OR EQUIVALENT.

SCT SERIESTROWEL — STABILIZER RING ASSY.

STABILIZER RING ASSY.

<u>NO</u>	<u>PART NO</u>	<u>PART NAME</u>	<u>QTY.</u>	<u>REMARKS</u>
1	1237	SCREW, SHC 5/16-18 X 3/4	4	
2	0161C	WASHER, LOCK, 5/16 MED	4	
3	21465-001	FLANGE, BEARING	4	
4	21292	STABILIZER RING ASSEMBLY	1	

SCT SERIES TROWEL — ENGINES, 5.5 HP, 8 HP, 11 HP HONDA ASSY.

ENGINE, 5.5 HP, 8 HP, 11 HP HONDA ASSY.

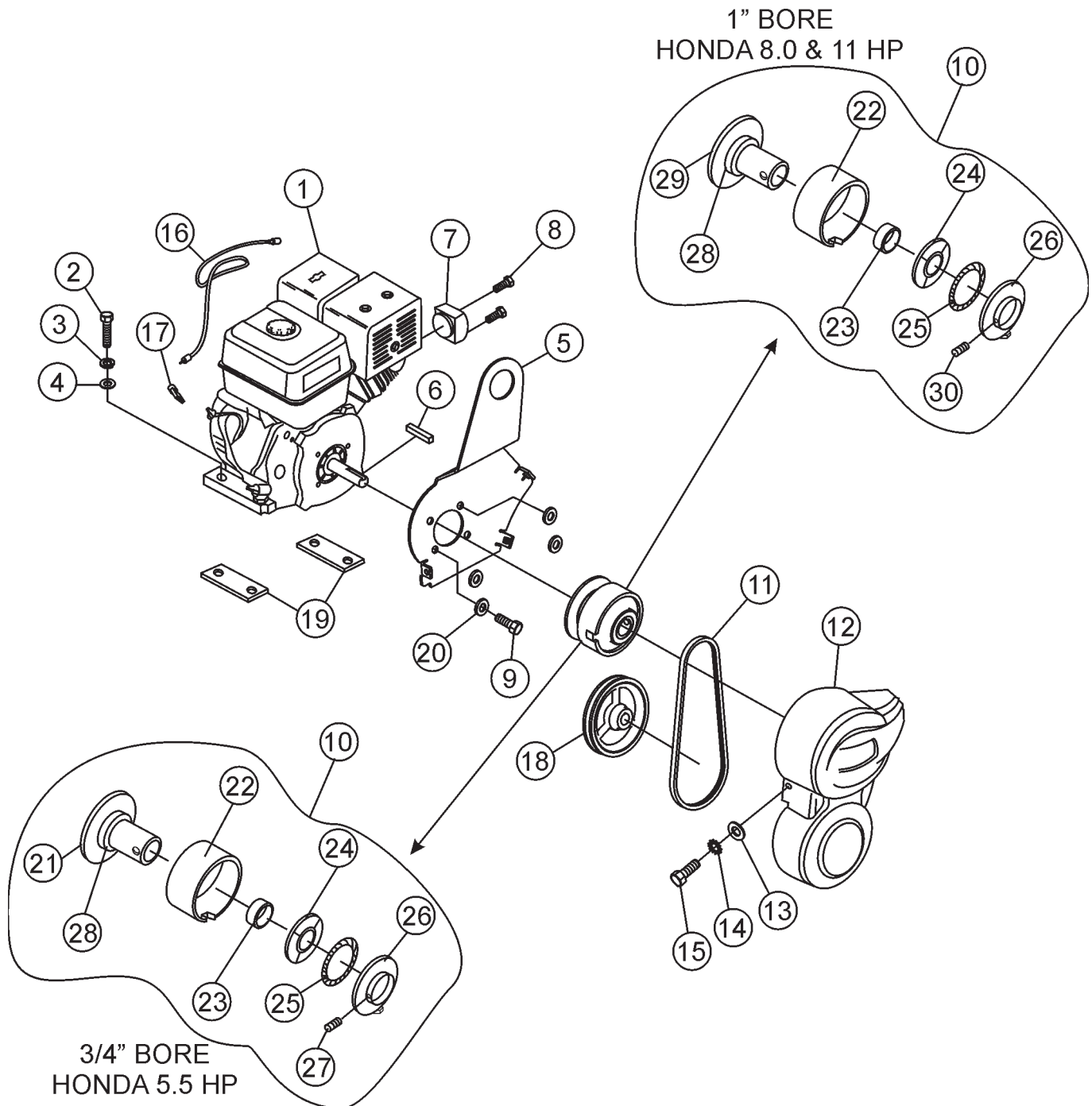

SCT SERIES TROWEL — ENGINES, 5.5 HP, 8 HP, 11 HP HONDA ASSY.

ENGINE, 5.5 HP, 8 HP, 11 HP HONDA ASSY.

<u>NO.</u>	<u>PART NO.</u>	<u>PART NAME</u>	<u>QTY.</u>	<u>REMARKS</u>
1	1386	ENGINE 5.5 HP HONDA GX160QX2	1	
1	1387	ENGINE 8 HP HONDA GX240K1QA2	1	
1	1388	ENGINE 11 HP HONDA GX340K1QAP2	1	
2	1391	HHCS 5/16-24 x 1-1/4"	4	
3	0161C	LOCK WASHER 5/16"	4	
4	0300B	FLAT WASHER 5/16"	4	
5	21293	LIFTING BAIL	1	... 5.5 HP MODEL
5	30043-351	LIFTING BAIL	1	... 8 HP & 11 HP MODELS
6	0627	KEY , SQUARE, 3/16 X 1-1/4	1	
7	1834	DEFLECTOR, EXHAUST	1	5.5 HP MODEL
8	1273	SCREW, HHST 8-32 X 3/8	1	5.5 HP MODEL
9	10229	SCREW, HHCS 5/16-24 x 1/2	4	
10	0255	AUTO CLUTCH ASSY. 3/4" BORE 5.5 HP MODEL	1	... INCLUDES ITEMS W/*
10	0250	AUTO CLUTCH ASSY. 1" BORE 8 & 11 HP MODELS	1	... INCLUDES ITEMS W/#
11	1390	BELT, A26	1	... 5.5 HP MODEL
11	0152-3	BELT, A28	1	... 8 HP & 11 HP MODELS
12	30102-002	BELT GUARD	1	
13	0948	WASHER, FLAT 1/4 SAE	3	
14	10031	WASHER, EXT SHKP 1/4	3	
15	131A	SCREW, HHC 1/4-20 X 3/4	3	
16	1488	WIRE, SAFETY SWITCH	1	
17	1475	CONNECTOR SPLICE	1	
18	21140	PULLEY, AK-54 X 3/4	1	
19	21141	SPACER, ENGINE MOUNT	2	... 5.5 HP MODEL
20	21256	SPACER, LIFT BAIL	4	... 5.5 HP MODEL
21*	0256	SPINDLE 3/4 BORE	1	... 5.5 HP MODEL
22*#	0251	CLUTCH HOUSING DRUM	1	
23*#	0458	CLUTCH HOUSING DRUM BUSHING	1	
24*#	0454	WEIGHT SET (INCLUDES 4 WEIGHTS)	1	
25*#	0855	SPRING	1	
26*#	0253	CLUTCH EXPANSION PLATE	1	
27*	1868	SHSS 3/8-24 X 3/4"	1	... 5.5 HP MODEL
28*#	0456	BELT RUNNER (BEARING)	1	
29#	0252	SPINDLE 1" BORE	1	... 8 HP & 11 HP MODELS
30#	0457	HSSS 3/8-24X1/2"	1	... 8 HP & 11 HP MODELS

SCT SERIESTROWEL — BLADES & ADJUSTMENT FIXTURE ASSY.

BLADES & ADJUSTMENT FIXTURE ASSY.

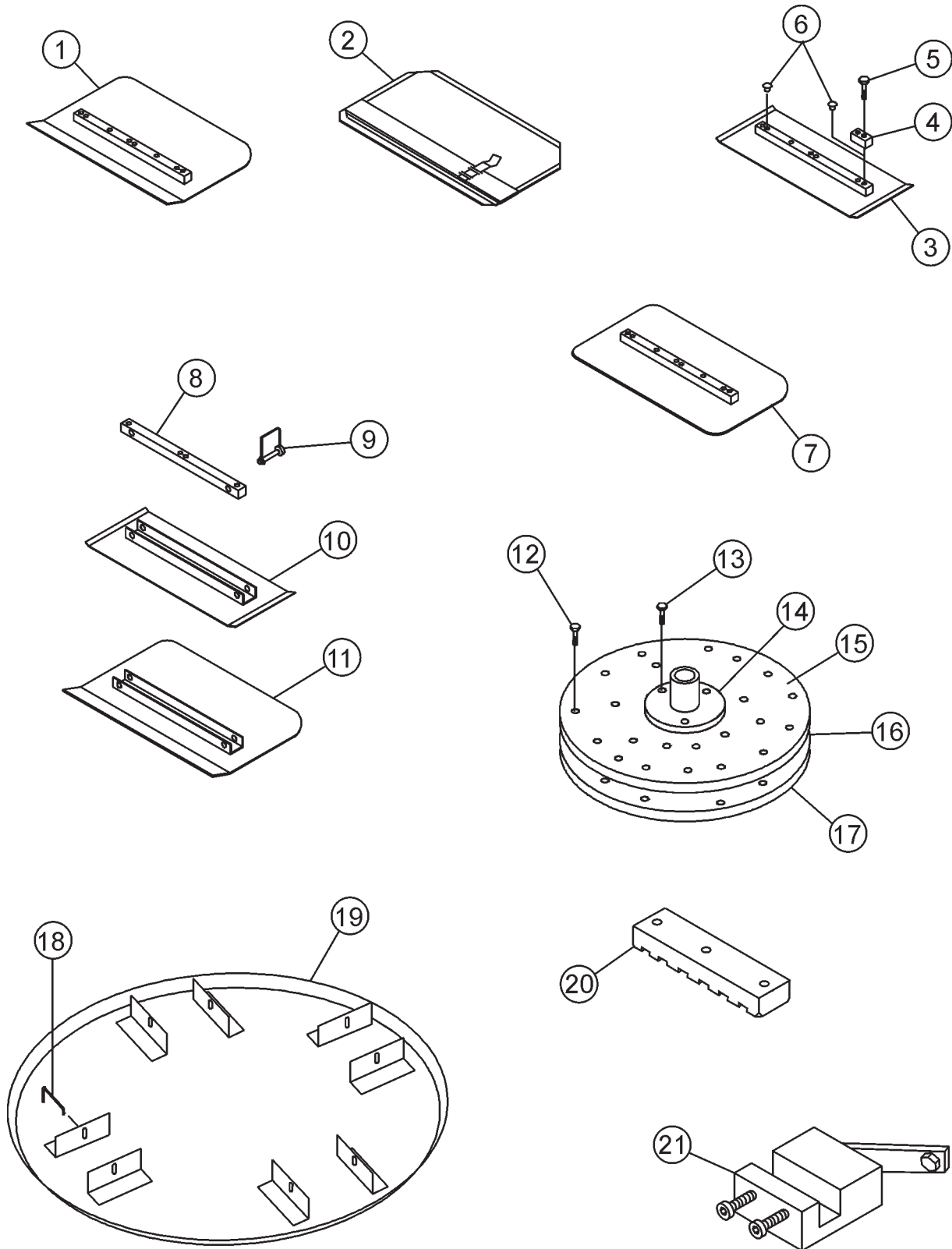

SCT SERIESTROWEL — BLADES & ADJUSTMENT FIXTURE ASSY.

BLADES & ADJUSTMENT FIXTURE ASSY.

<u>NO.</u>	<u>PART NO.</u>	<u>PART NAME</u>	<u>QTY.</u>	<u>REMARKS</u>
1		COMBO FLOAT & FINISH BLADE	4	CONTACT UNIT SALES DEPT./ACCESSORY ITEM
1		ENDURO COMBO FLOAT & FINISH BLADE	4	CONTACT UNIT SALES DEPT./ACCESSORY ITEM
2		FLOAT BLADE	4	CONTACT UNIT SALES DEPT./ACCESSORY ITEM
3		FINISH BLADE	4	CONTACT UNIT SALES DEPT./ACCESSORY ITEM
3		ENDURO FINISH BLADE W/ROTATING	4	CONTACT UNIT SALES DEPT./ACCESSORY ITEM
4	0201	GUARD RING LUG RING	4	
5	0202	HHCS 5/16-18X1" RING	4	
6	1434	TROWEL LUG (FINISH BLADE ONLY)	4	
7		REVERSIBLE COMBO BLADE	4	CONTACT UNIT SALES DEPT./ACCESSORY ITEM
8		UNIVERSAL MOUNTING BAR	4	CONTACT UNIT SALES DEPT./ACCESSORY ITEM
9		SNAP PIN 1/4"X1.3/4"	8	CONTACT UNIT SALES DEPT./ACCESSORY ITEM
10		UNIVERSAL FINISH BLADE	4	CONTACT UNIT SALES DEPT./ACCESSORY ITEM
10		ENDURO UNIVERSAL FINISH BLADE	4	CONTACT UNIT SALES DEPT./ACCESSORY ITEM
11		UNIVERSAL COMBO BLADE	4	CONTACT UNIT SALES DEPT./ACCESSORY ITEM
11		ENDURO UNIVERSAL COMBO BLADE	4	CONTACT UNIT SALES DEPT./ACCESSORY ITEM
12	0487	SHCS 3/8-16X1/2"	20	
13	0490	SHCS 7/16-14X1"	3	
14	0489	GRINDING DISC HUB	1	
15	0488	STONE MOUNT PLATE	1	
16		GRINDING DISC ASSY.	1	CONTACT UNIT SALES DEPT./ACCESSORY ITEM
17		GRINDING DISC STONE ONLY	1	CONTACT UNIT SALES DEPT./ACCESSORY ITEM
18		FLOAT DISC LATCH PIN	4	CONTACT UNIT SALES DEPT./ACCESSORY ITEM
19		FLOAT DISC	1	CONTACT UNIT SALES DEPT./ACCESSORY ITEM
20		GRINDING BRICK	4	CONTACT UNIT SALES DEPT./ACCESSORY ITEM
21		TROWEL ARM ADJ. FIXTURE ASSY.	1	CONTACT UNIT SALES DEPT./ACCESSORY ITEM

HONDA GX160K1QX2 — AIR CLEANER ASSY.

AIR CLEANER ASSY.

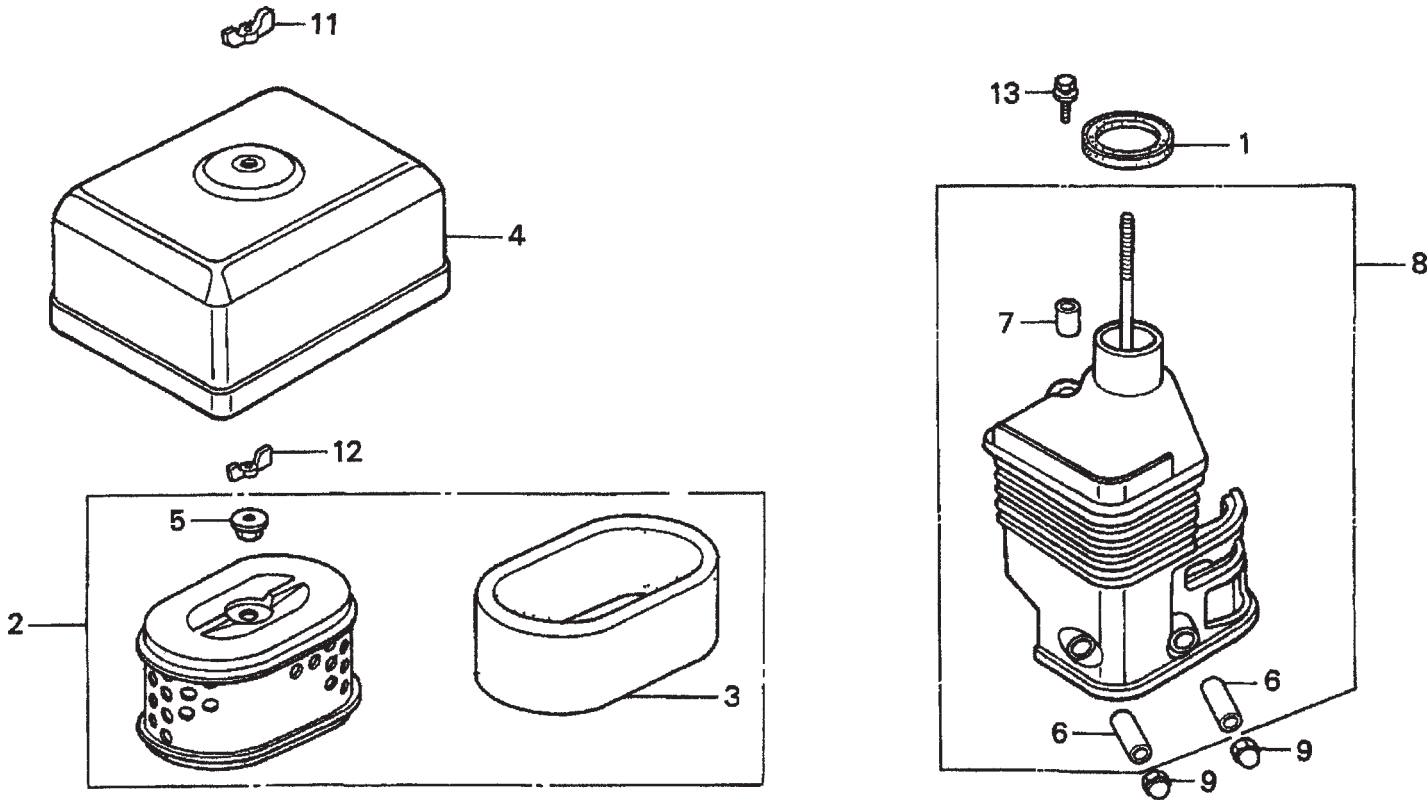

HONDA GX160K1QX2 — AIR CLEANER ASSY.

AIR CLEANER ASSY.

<u>NO.</u>	<u>PART NO.</u>	<u>PART NAME</u>	<u>QTY.</u>	<u>REMARKS</u>
1	16271ZE1000	GASKET, ELBOW	1	
2	17210ZE1505	ELEMENT, AIR CLEANER (DUAL)	1	
3	17218ZE1821	FILTER, OUTER	1	
4	17230ZE1820	COVER, AIR CLEANER (DUAL)	1	
5	17232891000	GROMMET, AIR CLEANER	1	
6	17238ZE7010	COLLAR, AIR CLEANER	2	
7	17239ZE1000	COLLAR B, AIR CLEANER	1	
8	17410ZE1020	ELBOW, AIR CLEANER	1	
9	90201415000	NUT, CAP 6MM	2	
11	90325044000	WINGNUT, TOOL BOX SETTING	1	USE FROM ENGINE SN 2836834
12	90325044000	WINGNUT, TOOL BOX SETTING	1	
13	957010602000	BOLT, FLANGE 6 X 20	1	USE FROM ENGINE SN 3385102

HONDA GX160K1QX2 — CAMSHAFT ASSY.

CAMSHAFT ASSY.

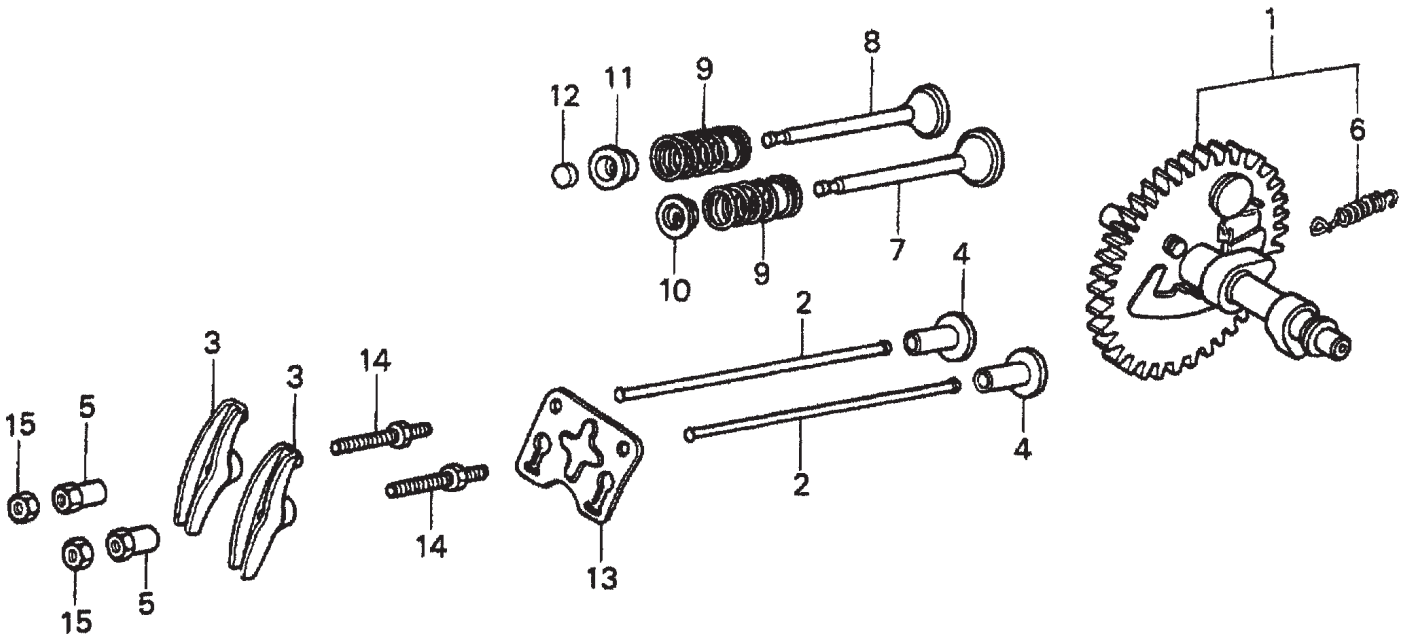

HONDA GX160K1QX2 — CAMSHAFT ASSY.

CAMSHAFT ASSY.

<u>NO.</u>	<u>PART NO.</u>	<u>PART NAME</u>	<u>QTY.</u>	<u>REMARKS</u>
1	14100ZE1812	CAMSHAFT ASSEMBLY	1	
2	14410ZE1010	ROD, PUSH	2	
3	14431ZE1000	ARM, VALVE ROCKER	2	
4	14441ZE1000	LIFTER, VALVE	2	USE UP TO ENGINE SN 4252173
4	14441ZE1010	LIFTER, VALVE	2	
5	14451ZE1013	PIVOT, ROCKER ARM	2	
6	14568ZE1000	SPRING, WEIGHT RETURN	1	
7	14711ZF1000	VALVE, INTAKE	1	
8	14721ZF1000	VALVE, EXHAUST	1	
9	14751ZF1000	SPRING VALVE	2	
10	14771ZE1000	RETAINER, INTAKE VALVE SPRING	1	
11	14773ZE1000	RETAINER, EXHAUST VALVE SPRING	1	
12	14781ZE1000	ROTATOR, VALVE	1	
13	14791ZE1010	PLATE, PUSH ROD GUIDE	1	
14	90012ZE0010	BOLT, PIVOT 8MM	2	
15	90206ZE1000	NUT, PIVOT ADJ.	2	

HONDA GX160K1QX2 — CARBURETOR ASSY.

CARBURETOR ASSY.

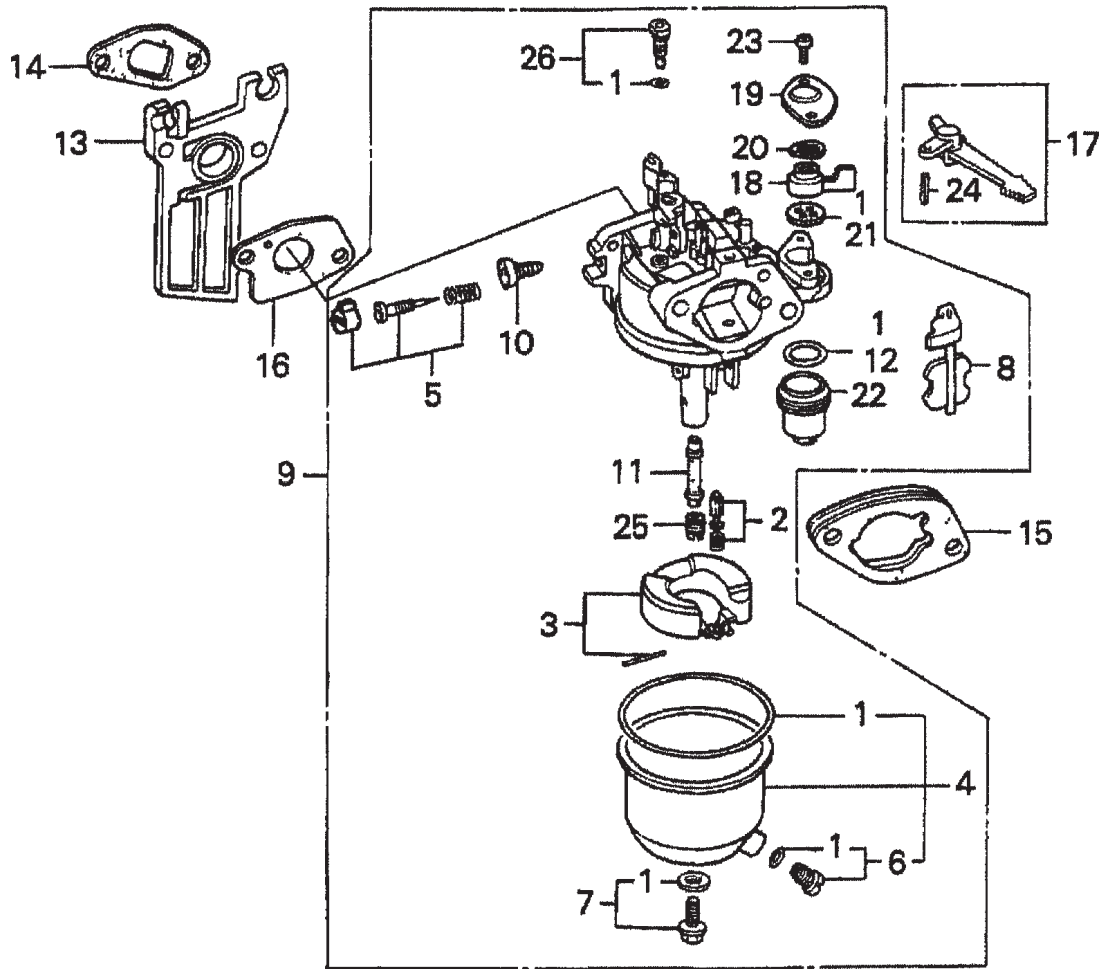

HONDA GX160K1QX2 — CARBURETOR ASSY.

CARBURETOR ASSY.

<u>NO.</u>	<u>PART NO.</u>	<u>PART NAME</u>	<u>QTY.</u>	<u>REMARKS</u>
1*#+%■	16010ZE1812	GASKET SET	1	
2*	16011ZE0005	VALVE SET, FLOAT	1	
3	16013ZE0005	FLOAT SET	1	
4*	16015ZE0831	CHAMBER SET, FLOAT	1	INCLUDES ITEMS/# USE FROM ENGINE SN BE65B B
5*	16016ZH7W01	SCREW SET	1	
6*#	16024ZE1811	SCREW SET, DRAIN	1	INCLUDES ITEM W/+
7*	16028ZE0005	SCREW SET B	1	INCLUDES ITEM W/%
8*	16044ZE0005	CHOKE SET	1	
9	16100ZH8W51	CARBURETOR ASSEMBLY, BE65B B	1	INCLUDES ITEMS/*
10*	16124ZE0005	SCREW, THROTTLE STOP	1	
11*	16166ZH8W50	NOZZLE, MAIN	1	
12*	16173001004	O- RING	1	
13	16211ZE1000	INSULATOR, CARBURETOR	1	
14	16212ZH8800	GASKET, INSULATOR	1	
15	16220ZE1020	SPACER, CARBURETOR	1	
16	16221ZH8801	GASKET, CARBURETOR	1	
17	16610ZE1000	LEVER, CHOKE STANDARD	1	INCLUDES ITEM W/\$
18*	16953ZE1812	LEVER, VALVE	1	
19	16954ZE1812	PLATE, LEVER SETTING	1	USE FROM ENGINE SN BE65B B
20*	16956ZE1811	SPRING, VALVE LEVER	1	
21*	16957ZE1812	GASKET, VALVE	1	
22*	16967ZE0811	CUP, FUEL STRAINER	1	
23*	93500030060H	SCREW, PAN 3 X 6	2	USE FROM ENGINE SN BE65B B
24\$	9430520122	PIN, SPRING 2 X 12	1	
25*	99101ZH80650	JET, MAIN #65 (OPTIONAL)	1	
25*	99101ZH80680	JET, MAIN #68 (OPTIONAL)	1	
26*	99204ZE00350	JET SET, PILOT #35	1	INCLUDES ITEM W/■

HONDA GX160K1QX2 — CONTROL ASSY.

CONTROL ASSY.

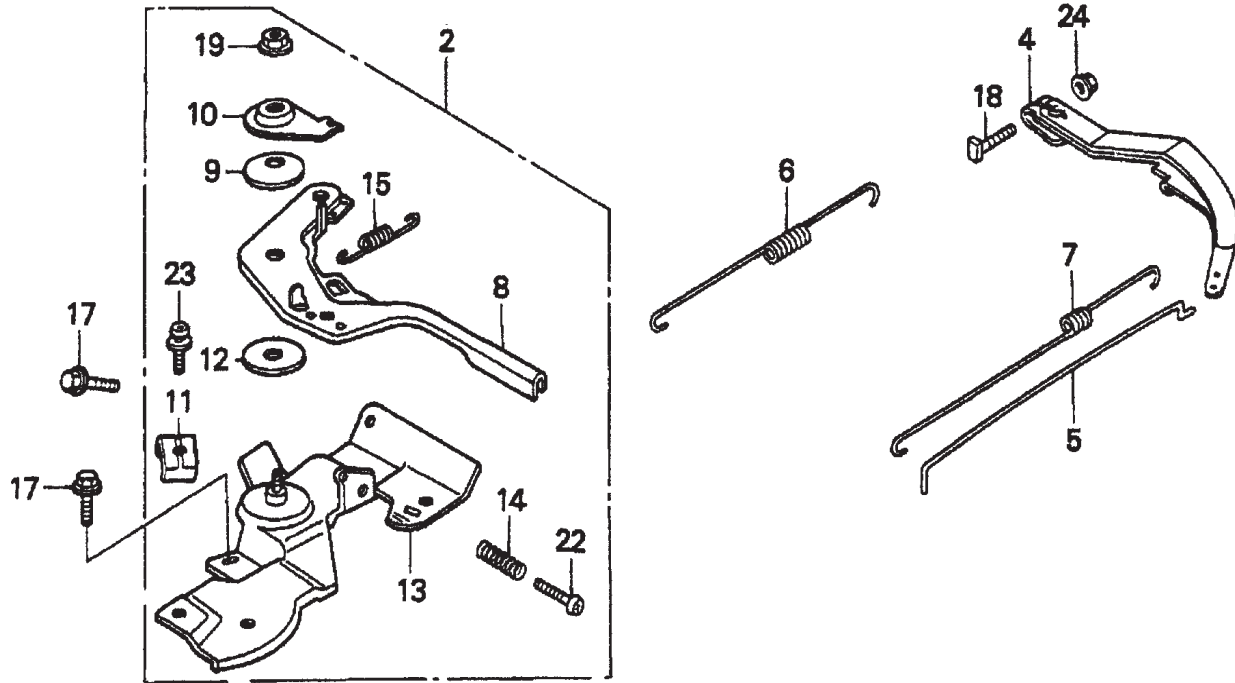

HONDA GX160K1QX2 — CONTROL ASSY.

CONTROL ASSY.

<u>NO.</u>	<u>PART NO.</u>	<u>PART NAME</u>	<u>QTY.</u>	<u>REMARKS</u>
2	16500ZH8823	CONTROL ASSEMBLY, REMOTE	1	INCLUDES ITEMS W/* USE FROM ENGINE SN 6331305
4	16551ZE0010	ARM, GOVERNOR	1	
5	16555ZE1000	ROD, GOVERNOR	1	
6	16561ZE1020	SPRING GOVERNOR	1	
7	16562ZE1020	SPRING, THROTTLE RETURN	1	
8*	16571ZH8020	LEVER, CONTROL	1	
9*	16574ZE1000	SPRING, LEVR	1	
10*	16575ZH8000	WASHER, CONTROL LEVER	1	
11*	16576891000	HOLDER, CABLE	1	
12*	16578ZE1000	SPACER, CONTROL LEVER	1	
13*	16580ZH8812	BASE, CONTROL (REMOTE)	1	USE FROM ENGINE SN 5551818 TO 6331304
14*	16584883300	SPRING, CONTROL ADJUSTING	1	
15*	16592ZE1810	SPRING, CABLE RETURN	1	
17	90013883000	BOLT, FLANGE 6 X 12 (CT200)	2	
18	90016ZE5010	BOLT, GOVERNOR ARM	1	
19*	90114SA0000	NUT, SELF- LOCK 6MM	1	
22*	93500050250H	SCREW, PAN 5 X 25	1	
23*	938930501600	SCREW, WASHER 5 X 16	1	
24	9405006000	NUT, FLANGE 6MM	1	

HONDA GX160K1QX2 — CRANKCASE COVER ASSY.

CRANKCASE COVER ASSY.

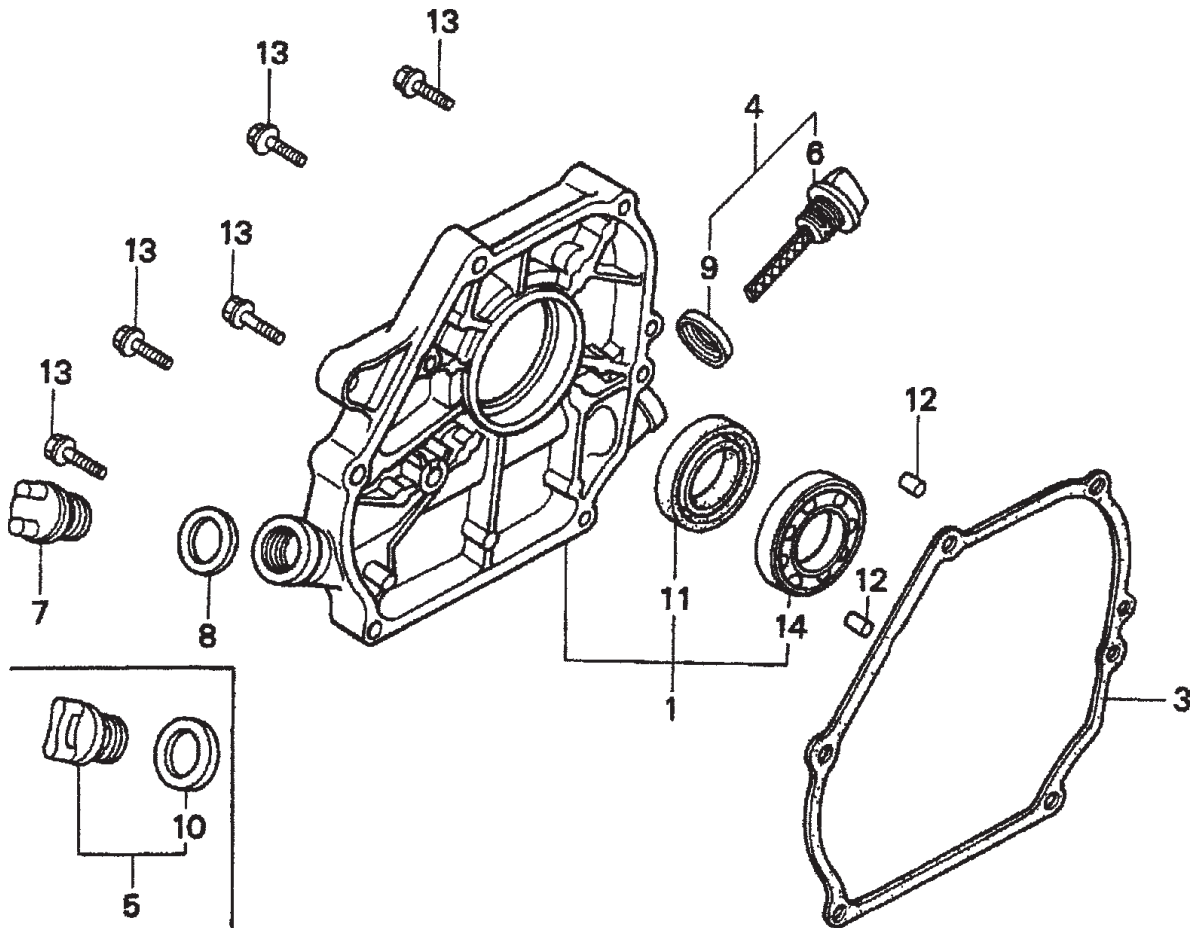

HONDA GX160K1QX2 — CRANKCASE COVER ASSY.

CRANKCASE COVER ASSY.

<u>NO.</u>	<u>PART NO.</u>	<u>PART NAME</u>	<u>QTY.</u>	<u>REMARKS</u>
1	11300ZE1641	COVER ASSEMBLY, CRANKCASE (U- TYPE)	1	INCLUDES ITEMS W/*
3	11381ZH8801	GASKET, CASE COVER (NON- ASBESTOS)	1	
4	15600ZE1003	CAP ASSEMBLY, OIL FILLER	1	
5	15600ZG4003	CAP ASSEMBLY, OIL FILLER	1	
9	15625ZE1003	GASKET, OIL FILLER CAP	1	
10	15625ZE1003	GASKET, OIL FILLER CAP	1	
11*	91202883005	OIL SEAL 25 X 41 X 6	1	
12	9430108140	PIN A, DOWEL 8 X 14	2	
13	957010803200	BOLT, FLANGE 8 X 32	6	
14*	961006205000	BEARING, RADIAL BALL 6205	1	

HONDA GX160K1QX2 — CRANKSHAFT ASSY.

CRANKSHAFT ASSY.

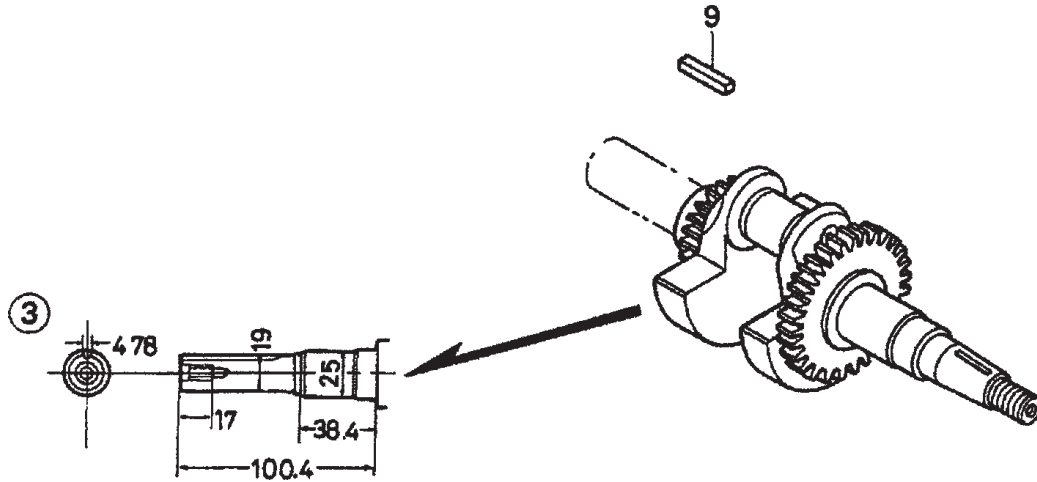

HONDA GX160K1QX2 — CRANKSHAFT ASSY.

CRANKSHAFT ASSY.

<u>NO.</u>	<u>PART NO.</u>	<u>PART NAME</u>	<u>QTY.</u>	<u>REMARKS</u>
3	13310ZE1601	CRANKSHAFT, Q- TYPE	1	
9	90745ZE1600	KEY, 4.78 X 4,78 X 38	1	

HONDA GX160K1QX2 — CYLINDER BARREL ASSY.

CYLINDER BARREL ASSY.

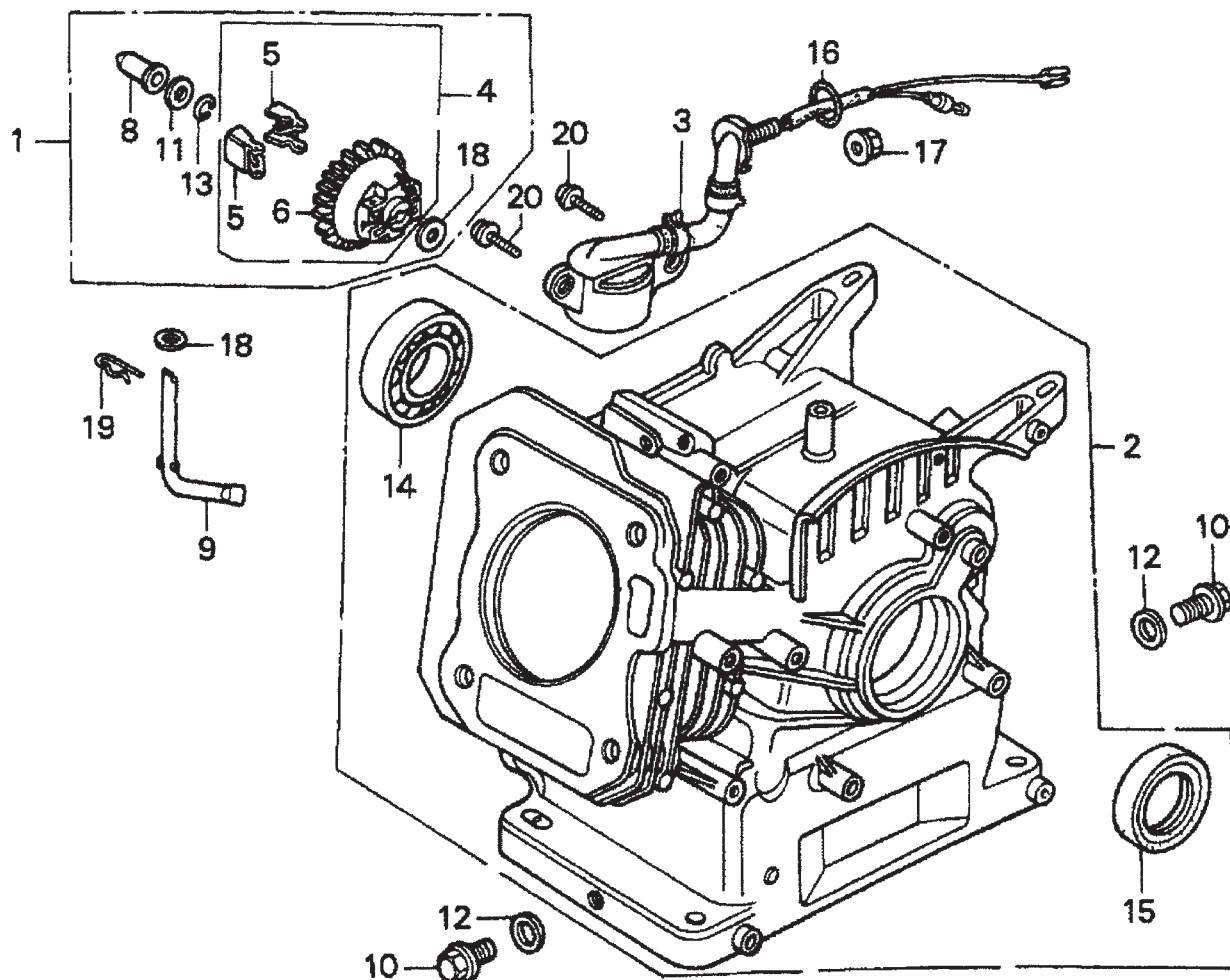

HONDA GX160K1QX2 — CYLINDER BARREL ASSY.

CYLINDER BARREL ASSY.

<u>NO.</u>	<u>PART NO.</u>	<u>PART NAME</u>	<u>QTY.</u>	<u>REMARKS</u>
2	12000ZH8811	CYLINDER ASSEMBLY, OIL ALERT	1	INCLUDES ITEMS W/*
3	15510ZE1033	SWITCH ASSEMBLY, OIL LEVEL	1	INCLUDES ITEMS W/%
4*	16510ZE1000	GOVERNOR ASSEMBLY	1	INCLUDES ITEMS W/#
5*#	16511ZE1000	WEIGHT, GOVERNOR	2	
6*#	16512ZE1000	HOLDER, GOVERNOR WEIGHT	1	
8*	16531ZE1000	SLIDER, GOVERNOR	1	
9	16541ZE1000	SHAFT, GOVERNOR ARM	1	
10	90131ZE1000	BOLT, DRAIN PLUG	2	
11*	80451ZE1000	WASHER, THRUST 6MM	1	
12	90601ZE1000	WASHER, DRAIN PLUG 10.2MM	2	
13*	90602ZE1000	CLIP, GOVERNOR HOLDER	1	
14%	91001ZF1003	BEARING, RADIAL BALL 6205	1	
15%	91202883005	OIL SEAL 25 X 41 X 6	1	
16	91353671003	O- RING 13.5 X 1.5 (ARAI)	1	
17	9405010000	NUT, FLANGE 10MM	1	
18*	9410106800	WASHER, PLAIN 6MM	2	
19	9425108000	PIN, LOCK 8MM	1	
20	957010601200	BOLT, FLANGE 6 X 12	2	

HONDA GX160K1QX2 — CYLINDER HEAD ASSY.

CYLINDER HEAD ASSY.

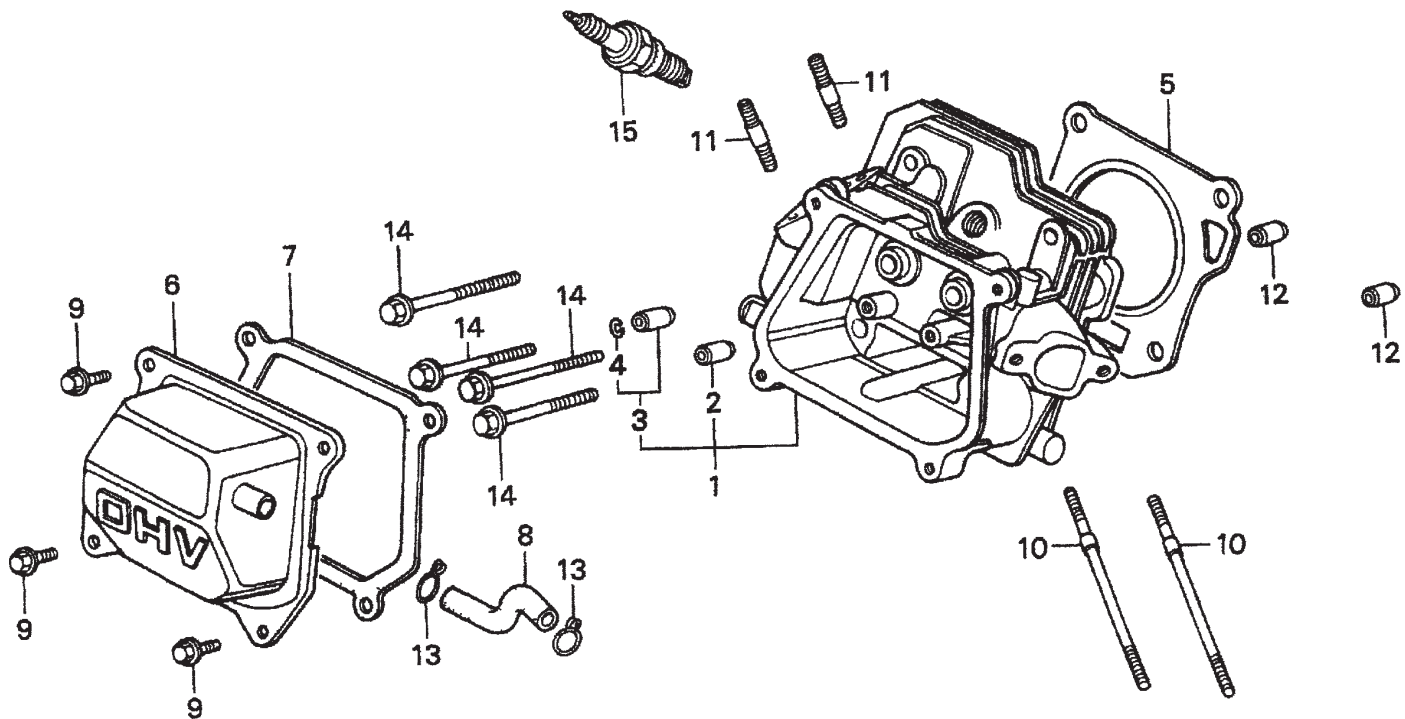

HONDA GX160K1QX2 — CYLINDER HEAD ASSY.

CYLINDER HEAD ASSY.

<u>NO.</u>	<u>PART NO.</u>	<u>PART NAME</u>	<u>QTY.</u>	<u>REMARKS</u>
1	12210ZH8000	CYLINDER HEAD	1	INCLUDES ITEMS W/*
2*	12204ZE1306	GUIDE, VALVE OS (OPTIONAL	1	
3*	12205ZE1315	GUIDE, EXHAUST VALVE OS (OPTIONAL)	1	INCLUDES ITEM W/%
4%	12216ZE5300	CLIP, VALVE GUIDE	1	
5	12251ZF1800	GASKET, CYLINDER HEAD	1	
6	12310ZE1010	COVER, HEAD	1	
7	12391ZE1000	GASKET, CYLINDER HEAD COVER	1	
8	15721ZH8000	TUBE, BREATHER	1	
9	90016ZE1000	BOLT, FLANGE 6 X13	4	
10	90043ZE1020	BOLT, STUD 6 X109	2	
11	90047ZE1000	BOLT, STUD 8 X 32	2	
12	9430110160	PIN A, DOWEL 10 X16	2	
14	957230806000	BOLT, FLANGE 8 X60	4	
15	9807956846	SPARK PLUG BPR6ES (NGK)	1	

HONDA GX160K1QX2 — FAN COVER ASSY.

FAN COVER ASSY.

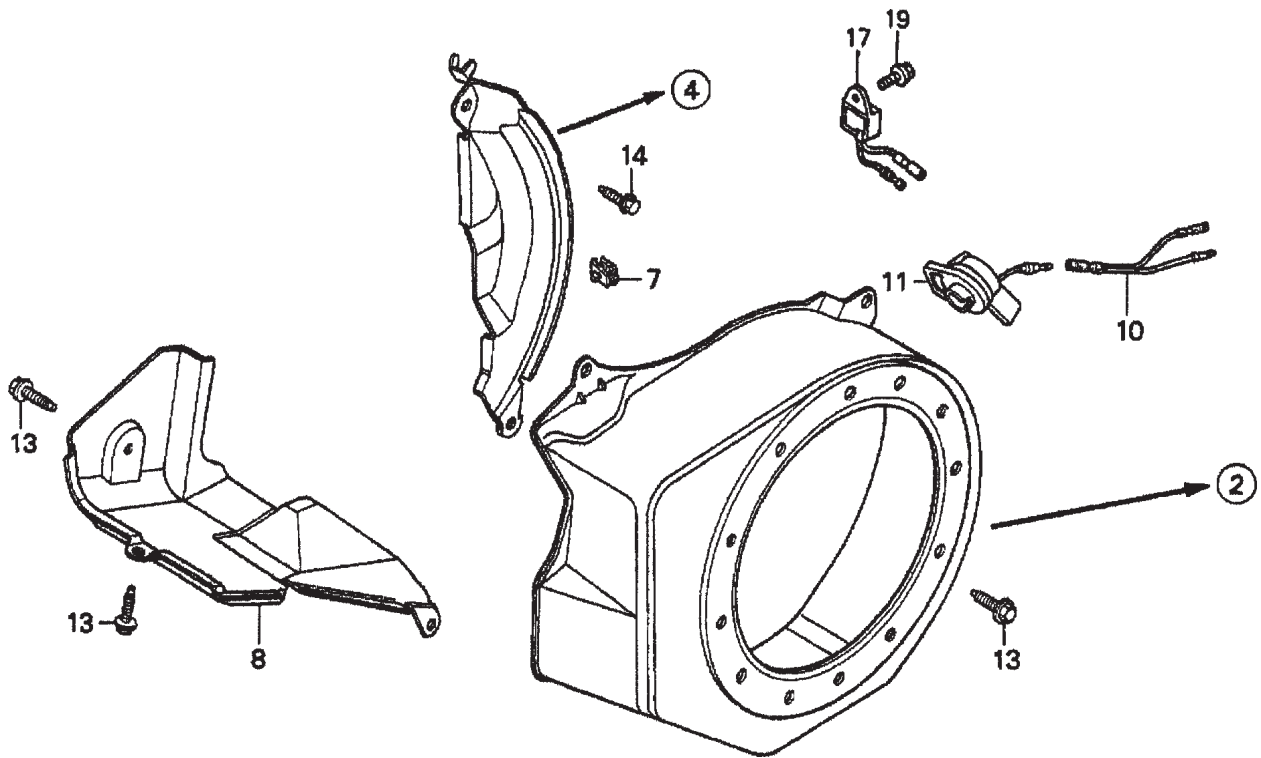

HONDA GX160K1QX2 — FAN COVER ASSY.

FAN COVER ASSY.

<u>NO.</u>	<u>PART NO.</u>	<u>PART NAME</u>	<u>QTY.</u>	<u>REMARKS</u>
2	19610ZE1000ZC	COVER, FAN "NH1" (BLACK)	1	
4	19611ZH8810	PLATE, SIDE (OIL ALERT)	1	
7	90601ZH7013	CLIP, HARNESS	1	
8	19630ZH8000	SHROUD	1	
10	32197ZH8003	SUB- HARNESS	1	
11	36100ZE1015	SWITCH ASSEMBLY, ENGINE STOP	1	
13	90013883000	BOLT, FLANGE 6 X12 (CT200)	6	
14	90022888010	BOLT, FLANGE 6 X20 (CT200)	1	
17	34150ZH7003	ALERT UNIT, OIL	1	
19	957010600800	BOLT, FLANGE 6 X8	1	

HONDA GX160K1QX2 — FLYWHEEL ASSY.

FLYWHEEL ASSY.

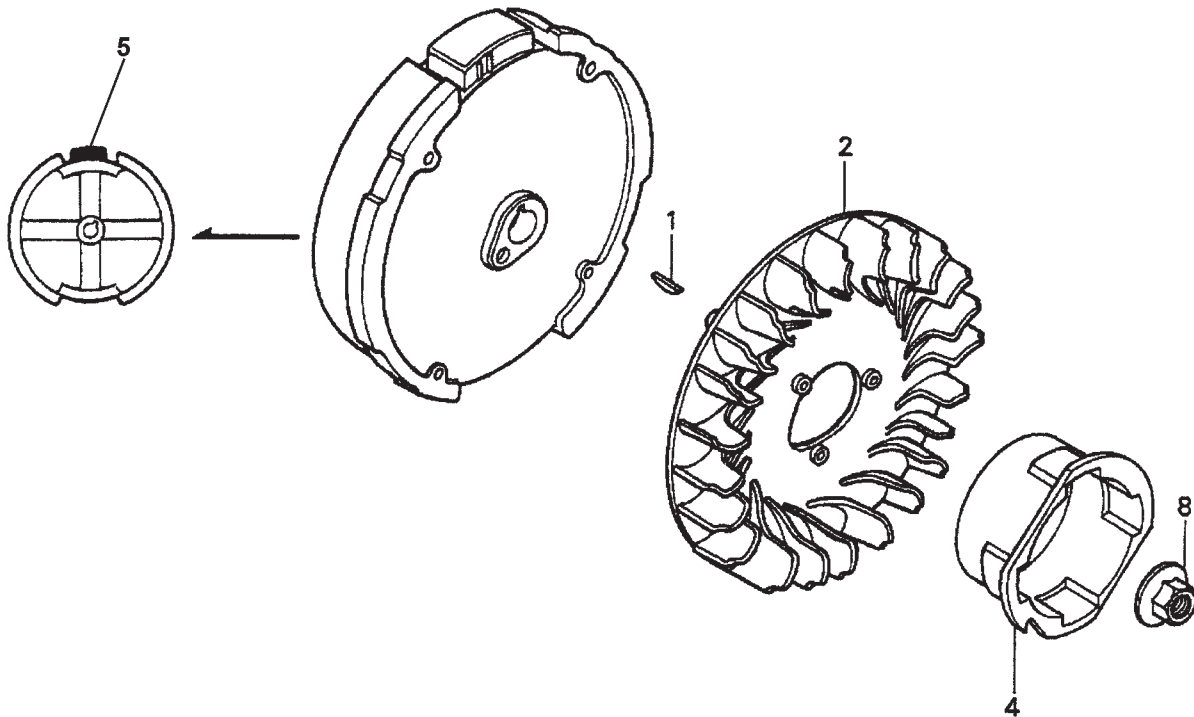

HONDA GX160K1QX2 — FLYWHEEL ASSY.

FLYWHEEL ASSY.

<u>NO.</u>	<u>PART NO.</u>	<u>PART NAME</u>	<u>QTY.</u>	<u>REMARKS</u>
1	13331357000	KEY, SPECIAL WOODRUFF (25 X18)	1	
2	19511ZE1000	FAN, COOLING	1	
4	28451ZH8003	PULLEY, STARTER	1	
5	31100ZE1010	FLYWHEEL	1	
5	31100ZE1810	FLYWHEEL, LAMP	1	
8	90201878003	NUT, SPECIAL 14MM	1	

HONDA GX160K1QX2 — FUEL TANK ASSY.

FUEL TANK ASSY.

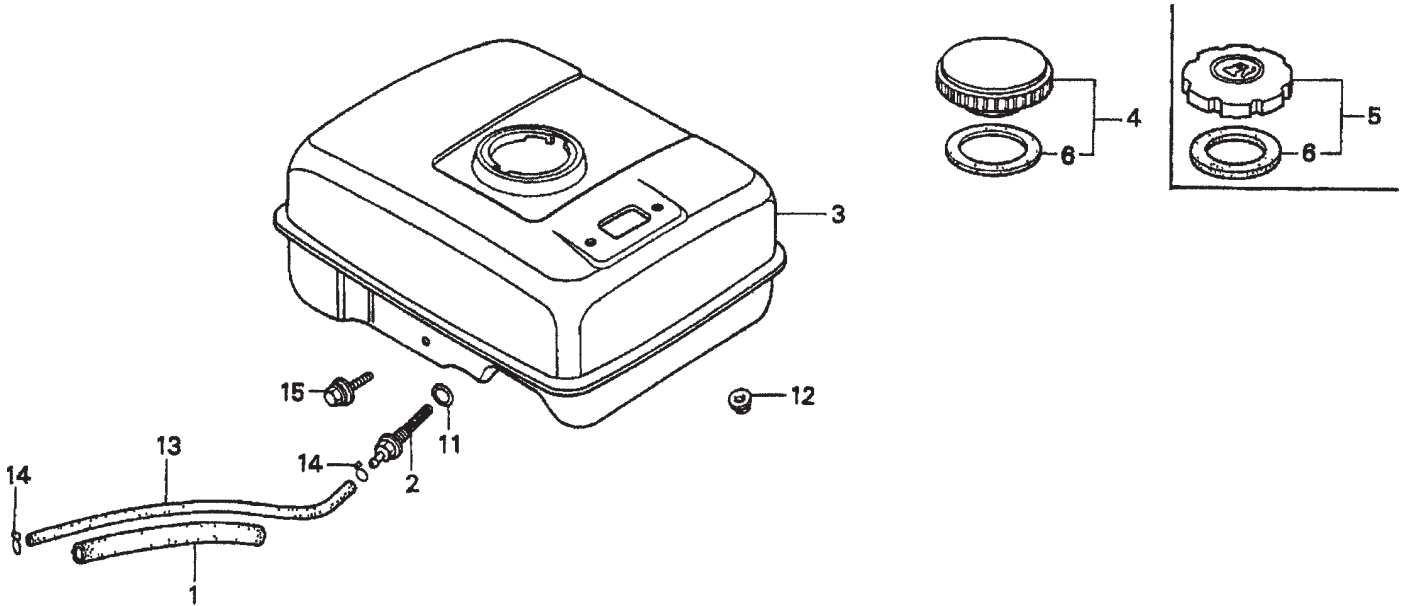

HONDA GX160K1QX2 — FUEL TANK ASSY.

FUEL TANK ASSY.

<u>NO.</u>	<u>PART NO.</u>	<u>PART NAME</u>	<u>QTY.</u>	<u>REMARKS</u>
1	16854ZH8000	RUBBER, SUPPORTER 107MM	1	
2	16955ZE1000	JOINT, FUEL TANK	1	
3	17510ZE1020ZB	TANK, FUEL *R8* (BRIGHT RED)	1	
3	17510ZE1020ZF	TANK, FUEL *NH1* (BLACK)	1	
5	17620ZH7023	CAP, FUEL FILLER	1	INCLUDES ITEM W/*
6*	17631ZH7003	GASKET, FUEL FILLER CAP	1	
11	91353671003	O- RING 13.5 X1.5 (ARAI)	1	
12	9405006000	NUT, FLANGE 6MM	2	
13	950014500360M	BULK HOSE, FUEL 4.5 X 3000 (4.5 X 140)	1	
14	9500202080	CLIP, TUBE B8	2	
15	957010602500	BOLT, FLANGE 6 X 25	1	

HONDA GX160K1QX2 — IGNITION COIL ASSY.

IGNITION COIL ASSY.

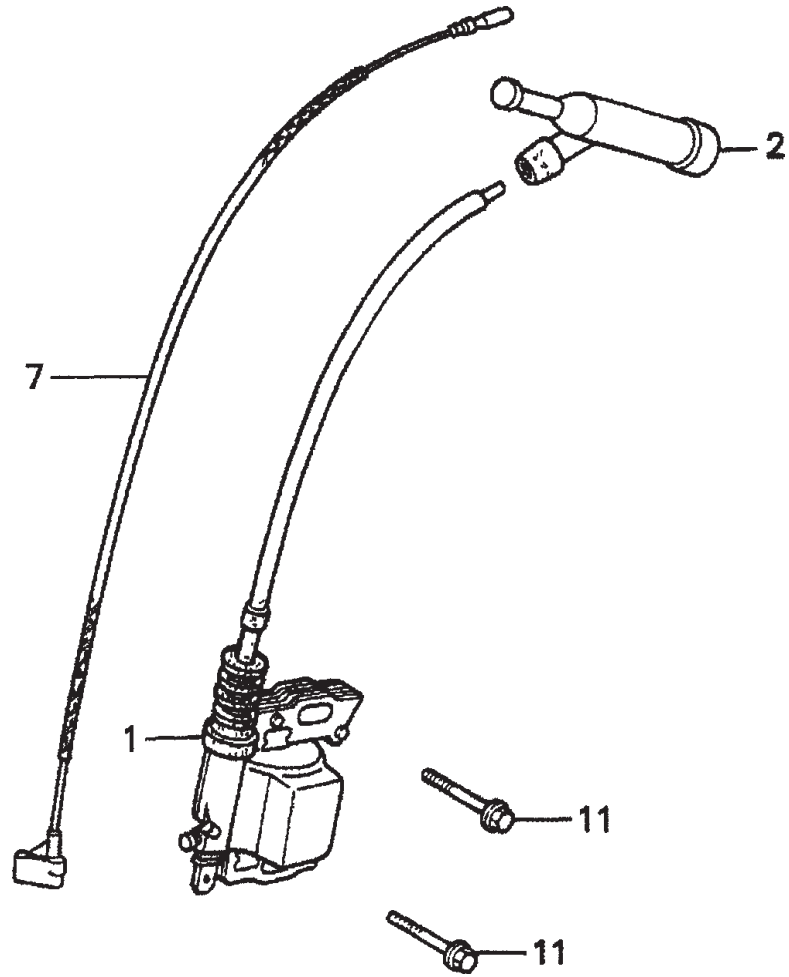

HONDA GX160K1QX2 — IGNITION COIL ASSY.

IGNITION COIL ASSY.

<u>NO.</u>	<u>PART NO.</u>	<u>PART NAME</u>	<u>QTY.</u>	<u>REMARKS</u>
1	30500ZE1033	COIL ASSEMBLY, IGNITION	1	
2	30700ZE1013	CAP ASSEMBLY, NOISE SUPPRESSOR	1	
7	36101ZE1010	WIRE, STOP SWITCH 370MM	1	
11	90121952000	BOLT, FLANGE 6 X25	2	

HONDA GX160K1QX2 — MUFFLER ASSY.

MUFFLER ASSY.

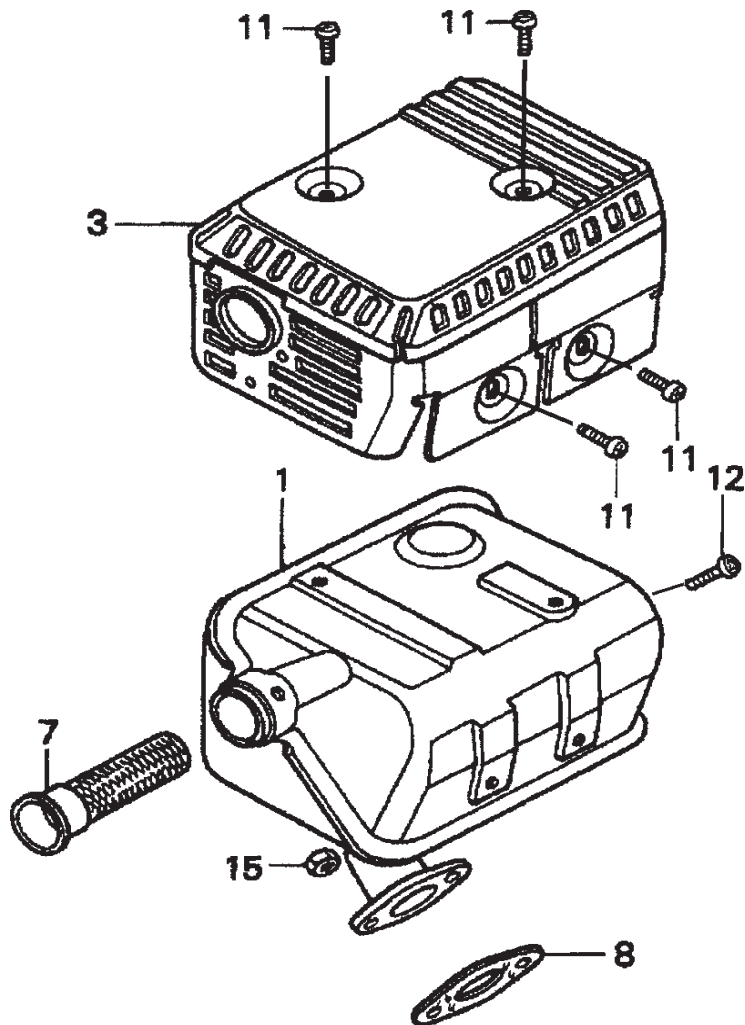

HONDA GX160K1QX2 — MUFFLER ASSY.

MUFFLER ASSY.

<u>NO.</u>	<u>PART NO.</u>	<u>PART NAME</u>	<u>QTY.</u>	<u>REMARKS</u>
1	18310ZF1000	MUFFLER	1	
1	18310ZH8810	MUFFLER (OPTIONAL)	1	
3	18320ZF1H01	PROTECTOR, MUFFLER	1	
7	18355ZE1000	ARRESTER, SPARK (OPTIONAL)	1	
8	18381ZH8800	GASKET, MUFFLER	1	
11	90050ZE1000	SCREW, TAPPING 5 X 8 (OPTIONAL)	4	
12	90055ZE1000	SCREW, TAPPING 4 X 6 (OPTIONAL)	1	
15	94001080000S	NUT, HEX. 8MM	2	

HONDA GX160K1QX2 — PISTON ASSY.

PISTON ASSY.

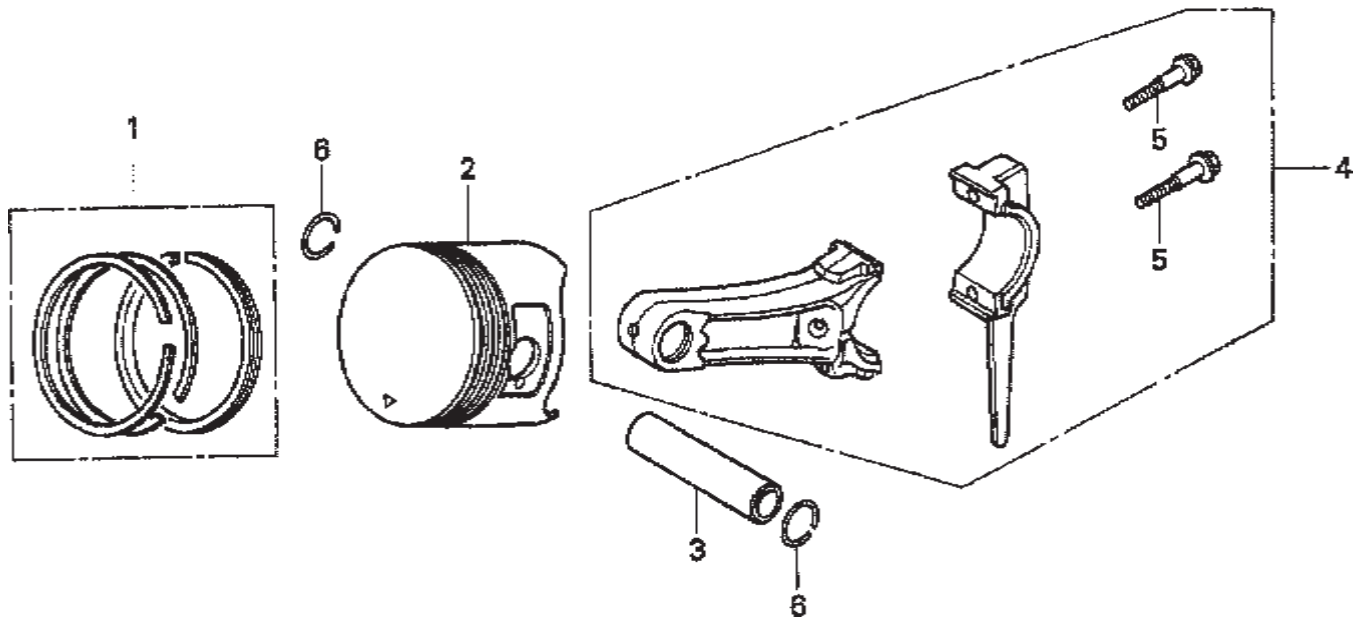

HONDA GX160K1QX2 — PISTON ASSY.

PISTON ASSY.

<u>NO.</u>	<u>PART NO.</u>	<u>PART NAME</u>	<u>QTY.</u>	<u>REMARKS</u>
1	13010ZF1023	RING SET, PISTON (STANDARD)	1	USE UP TO ENG S/N 5495899
1	13010ZH8941	RING SET, PISTON (STANDARD)	1	USE FROM ENG S/N 5495900
1	13011ZF1023	RING SET, PISTON (OS 0.25)	1	USE UP TO ENG S/N 5495899
1	13011ZH8941	RING SET, PISTON (OS 0.25), OPTIONAL	1	USE FROM ENG S/N 5495900
1	13012ZF1023	RING SET, PISTON (OS 0.50), OPTIONAL	1	USE UP TO ENG S/N 5495899
1	13012ZH8941	RING SET, PISTON (OS 0.50), OPTIONAL	1	USE FROM ENG S/N 5495900
1	13013ZF1023	RING SET, PISTON (0.75), OPTIONAL	1	USE UP TO ENG S/N 5495899
1	13013ZH8941	RING SET, PISTON (0.75), OPTIONAL	1	USE FROM ENG S/N 5495900
2	13101ZH8000	PISTON (STANDARD)	1	
2	13102ZH8000	PISTON (OS 0.25), OPTIONAL	1	
2	13103ZH8000	PISTON (OS 0.50), OPTIONAL	1	
2	13104ZH8000	PISTON (0.75), OPTIONAL	1	
3	13111ZE1000	PIN, PISTON	1	
4	132AOZE1000	ROD ASSY., CONNECTING (US 0.25), OPT.	1	
4	13200ZE1010	ROD ASSEMBLY, CONNECTING	1	
5	90001ZE1000	BOLT, CONNECTING ROD	2	
6	90551ZE1000	CLIP, PISTON PIN 18MM	2	

HONDA GX160K1QX2 — RECOIL STARTER ASSY.

RECOIL STARTER ASSY.

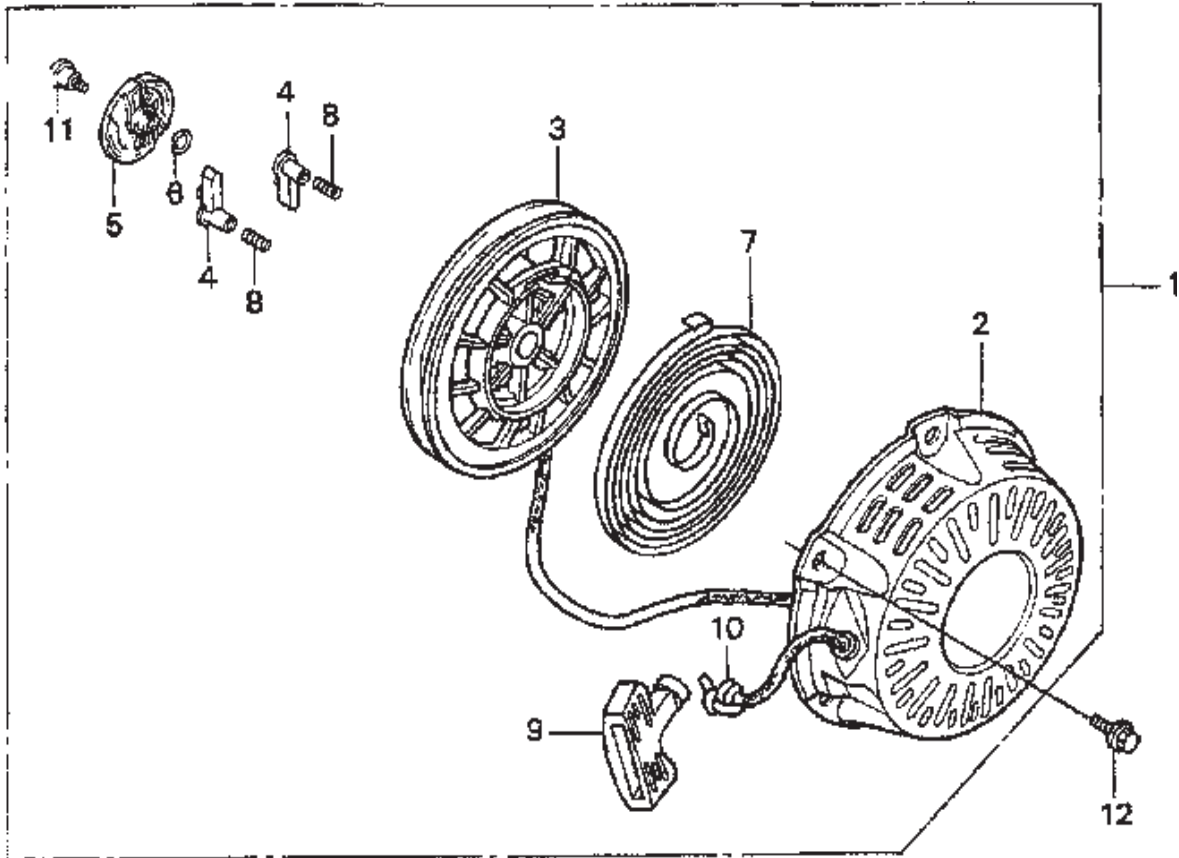

HONDA GX160K1QX2 — RECOIL STARTER ASSY.

RECOIL STARTER ASSY.

<u>NO.</u>	<u>PART NO.</u>	<u>PART NAME</u>	<u>QTY.</u>	<u>REMARKS</u>
1	28400ZH8013ZB	STARTER ASSY., RECOIL "NH1" BLACK	1	INCLUDES ITEM W/*
2*	28410ZH8003ZB	CASE, RECOIL STARTER "NH1" BLACK	1	
3*	28420ZH8013	REEL, RECOIL STARTER	1	
4*	28422ZH8013	RATCHET, STARTER	2	
5*	28433ZH8003	GUIDE, RATCHET	1	
6*	28441ZH8003	SPRING, FRICTION	1	
7*	28442ZH8003	SPRING, RECOIL STARTER	1	
8*	28443ZH8003	SPRING, RETURN	2	
9*	28461ZH8003	KNOB, RECOIL STARTER	1	
10*	28462ZH8003	ROPE, RECOIL STARTER	1	
11*	90003ZH8003	SCREW, SETTING	1	
12	90008ZE2003	BOLT, FLANGE 6 X10	3	

HONDA GX160K1QX2 — GASKET KIT ASSY.

GASKET KIT ASSY.

<u>NO.</u>	<u>PART NO.</u>	<u>PART NAME</u>	<u>QTY.</u>	<u>REMARKS</u>
	06111ZH8405	GASKET KIT	1	INCLUDES ITEMS W/*
1*	11381ZH8801	GASKET CASE COVER (NON- ASBESTOS)	1	
2*	12251ZF1800	GASKET, CYLINDER HEAD	1	
3*	12391ZE1000	GASKET, CYLINDER HEAD COVER	1	
4*	16212ZH8800	GASKET, INSULATOR	1	
5*	16221ZH8801	GASKET, CARBURETOR	1	
6*	18381ZH8800	GASKET, MUFFLER	1	

HONDA GX160K1QX2 — ENGINE LABELS ASSY.

ENGINE LABELS ASSY.

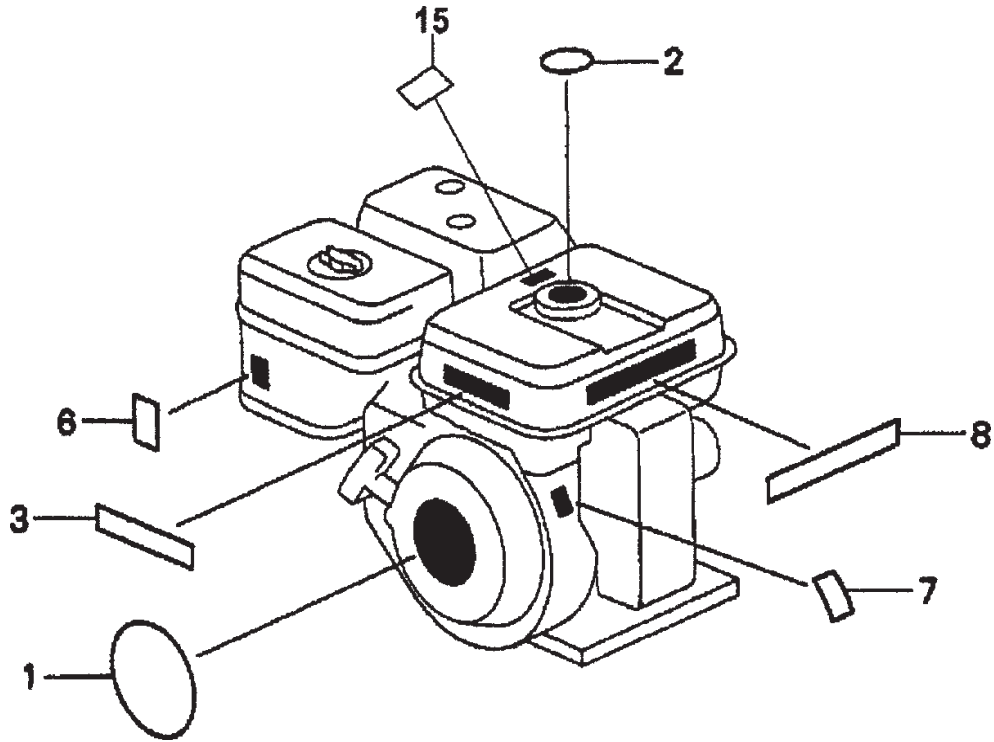

HONDA GX160K1QX2 — ENGINE LABELS ASSY.

ENGINE LABELS ASSY.

<u>NO.</u>	<u>PART NO.</u>	<u>PART NAME</u>	<u>QTY.</u>	<u>REMARKS</u>
1	87521ZH8020	ENBLEM 5.5	1	USE FROM ENGINE SN 7438468
2	87522ZE1810	MARK, CAUTION (EXTERNAL)	1	USE UP TO ENGINE SN 3063877
3	87522ZH9000	LABEL, CAUTION	1	
6	87528ZE1810	MARK, CHOKE	1	
7	87530ZH8810	LABEL, SPECIFICATION (EXTERNAL)	1	
8	87532ZH8810	MARK, OIL ALERT (E)	1	
15	887586ZH7W00	LABEL, FUEL CAUTION	1	

HONDA GX240K1QA2 ENGINE — AIR CLEANER ASSY.

AIR CLEANER ASSY.

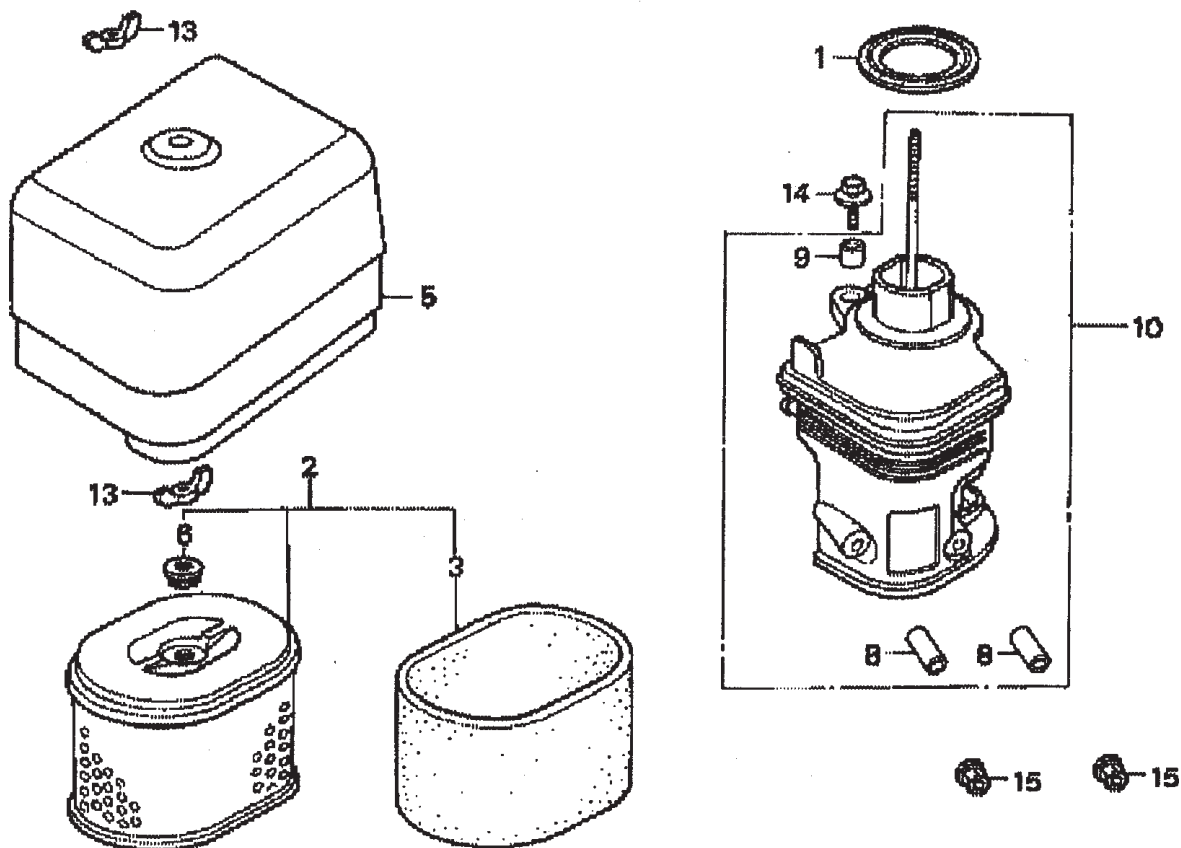

HONDA GX240K1QA2 ENGINE — AIR CLEANER ASSY.

AIR CLEANER ASSY.

<u>NO.</u>	<u>PART NO.</u>	<u>PART NAME</u>	<u>QTY.</u>	<u>REMARKS</u>
1	16271ZE2000	GASKET, ELBOW	1	
2	17210ZE2822	ELEMENT, AIR CLEANER, DUAL	1	INCLUDES ITEMS W/*
3*	17218ZE2505	FILTER, OUTER	1	
5	17231ZH9820	COVER, AIR CLEANER	1	
6	17232891000	GROMMET, AIR CLEANER	1	
8%	17238ZE2310	COLLAR, AIR CLEANER	2	
9%	17239ZE1000	COLLAR B, AIR CLEANER	1	
10	17410ZE2020	ELBOW COMP., AIR CLEANER	1	INCLUDES ITEMS W/%
13	90325044000	WINGNUT, TOOL BOX SETTING	2	
14	90009ZE2003	BOLT- WASHER 6 X 22	1	
15	9405006000	NUT, FLANGE 6MM	2	

HONDA GX240K1QA2 ENGINE — CAMSHAFT ASSY.

CAMSHAFT ASSY.

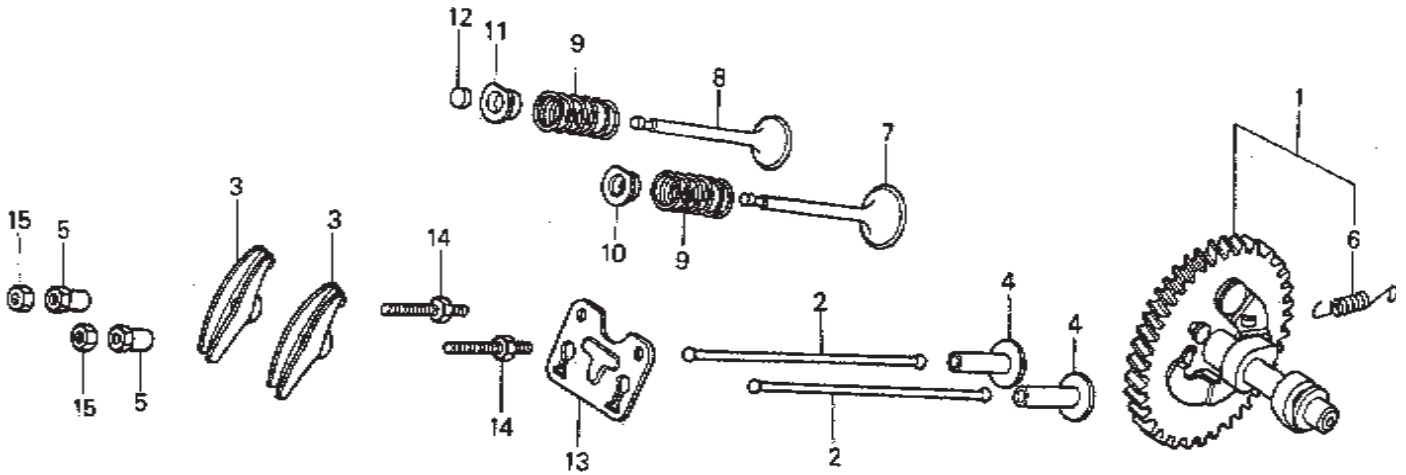

HONDA GX240K1QA2 ENGINE — CAMSHAFT ASSY.

CAMSHAFT ASSY.

<u>NO.</u>	<u>PART NO.</u>	<u>PART NAME</u>	<u>QTY.</u>	<u>REMARKS</u>
1	14100ZE2W01	CAMSHAFT ASSY.	1	INCLUDES ITEMS W/*
2	14410ZE2013	ROD PUSH	2	
3	14431ZE2010	ARM VALVE ROCKER	2	
4	14441ZE2000	LIFTER VALVE	2	
5	14451ZE1013	PIVOT ROCKER ARM	2	
6*	14568ZE1000	SPRING, WEIGHT RETURN	1	
7	14711ZE2000	VALVE, IN.	1	
8	14721ZE2000	VALVE, EX.	1	
9	14751ZE2003	SPRING, VALVE	2	
10	14771ZE2000	RETAINER, IN. VALVE SPRING	1	
11	14773ZE2000	RETAINER, EX. VALVE SPRING	1	
12	14781ZE2000	ROTATOR, VALVE	1	
13	14791ZE2010	PLATE, PUSH ROD GUIDE	1	
14	90012ZE0010	BOLT, PIVOT 8MM	2	
15	90206ZE1000	NUT, PIVOT ADJ.	2	

HONDA GX240K1QA2 ENGINE — CARBURETOR ASSY.

CARBURETOR ASSY.

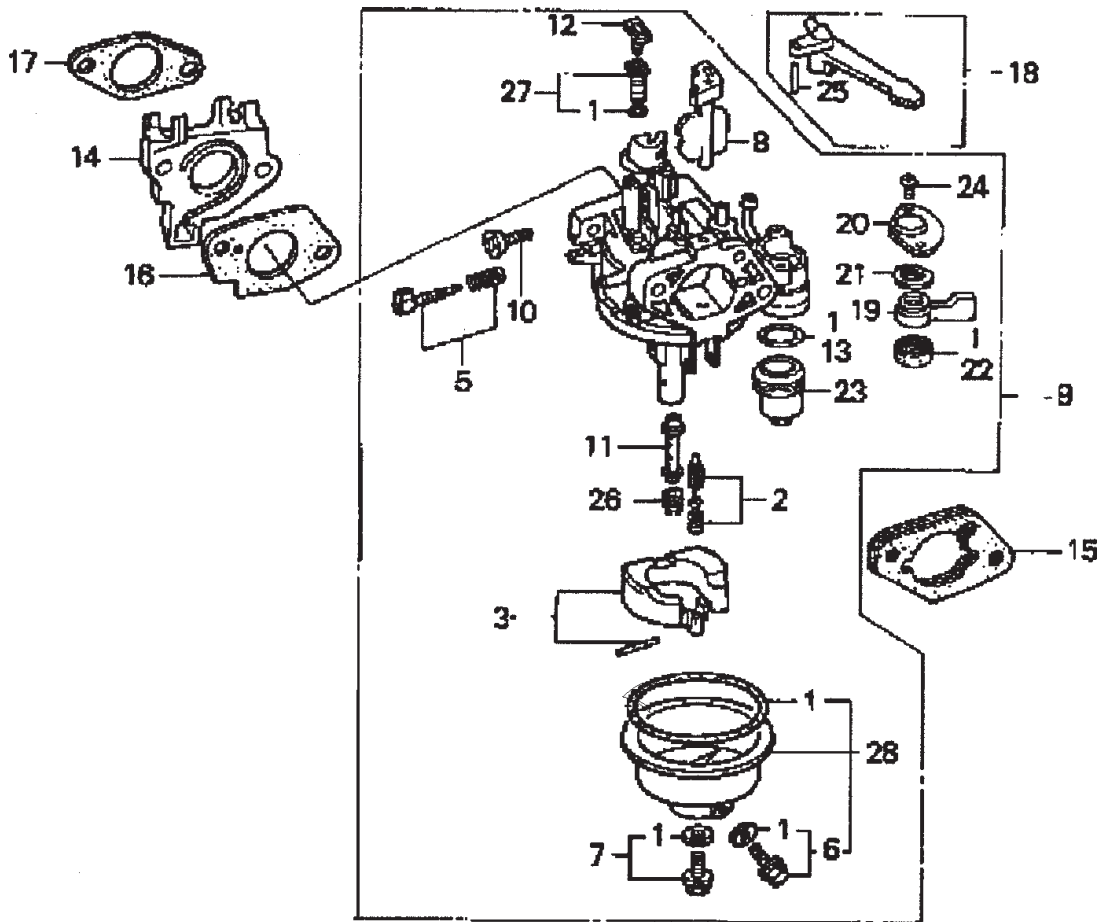

HONDA GX240K1QA2 ENGINE — CARBURETOR ASSY.

CARBURETOR ASSY.

<u>NO.</u>	<u>PART NO.</u>	<u>PART NAME</u>	<u>QTY.</u>	<u>REMARKS</u>
1* %+	16010ZE2812	GASKET SET	1	
2*	16011ZA0931	VALVE SET, FLOAT	1	
3*	16013ZA0931	FLOAT SET	1	
5*	16016ZHW01	SCREW SET	1	
6*+	16024ZE1811	SCREW SET, DRAIN	1	
7*	16028ZE0005	SCREW SET B	1	
8*	16028ZE2005	CHOKE SET	1	
9	16100ZE2W71	CARBURETOR ASSY.....	1	INCLUDES ITEMS W/*
10*	16124ZE0005	SCREW, THROTTLE STOP	1	
11*	16166ZE2W70	NOZZLE, MAIN	1	
12*	16172ZE3W10	COLLAR, SET	1	
13*	16173001004	O-RING	1	
14	16211ZE2000	INSULATOR, CARBURETOR	1	
15	16220ZA0702	SPACER COMP., CARBURETOR	1	
16	16221ZA0800	GASKET, CARBURETOR	1	
17	16223ZA0800	GASKET, INSULATOR	1	
18	16610ZE1000	LEVER COMP., CHOKE, STD.	1	INCLUDES ITEMS W/■
19*	16953ZE1812	LEVER, VALVE	1	
20*	16954ZE1811	PLATE, LEVER SETTING	1	
21*	16956ZE1811	SPRING, VALVE LEVER	1	
22*	16957ZE1812	GASKET, VALVE	1	
23*	16967ZE0811	CUP, FUEL STRAINER	1	
24	93500030060H	SCREW, PAN 3 X 6	2	
25■	9430520122	PIN, SPRING 2 X 12	1	
26	99101ZH80820	JET, MAIN #82, OPTIONAL	1	
26	99101ZH80850	JET, MAIN #85, OPTIONAL	1	
26*	99101ZH80880	JET, MAIN #88	1	
27*	99204ZE20400	JET SET, PILOT #40	1	INCLUDES ITEMS W/ %
28*	16015ZE8005	CHAMBER SET, FLOAT	1	INCLUDES ITEMS W/+

HONDA GX240K1QA2 ENGINE — CONTROL ASSY.

CONTROL ASSY.

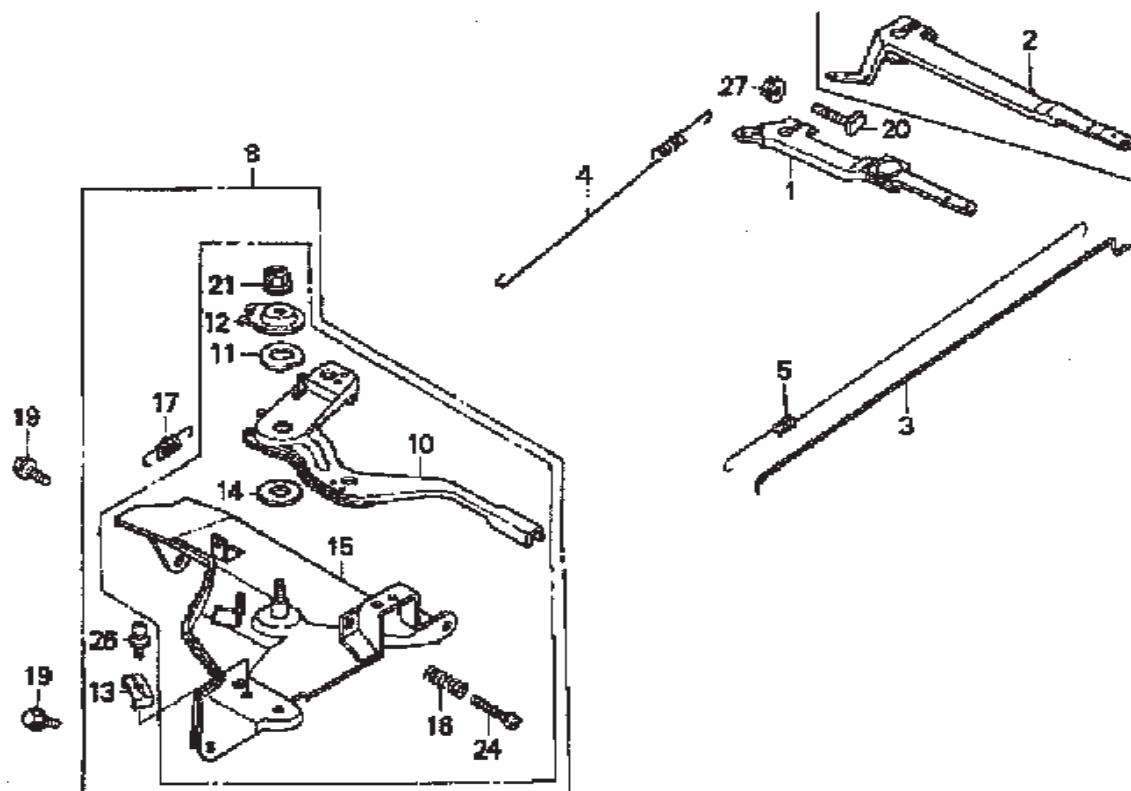

HONDA GX240K1QA2 ENGINE — CONTROL ASSY.

CONTROL ASSY.

<u>NO.</u>	<u>PART NO.</u>	<u>PART NAME</u>	<u>QTY.</u>	<u>REMARKS</u>
1	16550ZE2700	ARM, GOVERNOR	1	
2	16551ZE2000	ARM, GOVERNOR	1	
3	16555ZE2000	ROD, GOVERNOR	1	
4	16561ZE2000	SPRING, GOVERNOR	1	
5	16562ZE2000	SPRING, THROTTLE RETURN	1	
8	16570ZE2W20	CONTROL ASSY., REMOTE	1	INCLUDES ITEMS W/*
10*	16571ZE2W00	LEVER, CONTROL	1	
11*	16574ZE1000	SPRING, LEVER	1	
12*	16575ZE2W00	WASHER, CONTROL LEVER	1	
13*	16576891000	HOLDER, CABLE	1	
14*	16578ZE1000	SPACER, CONTROL LEVER	1	
15*	16581ZE2W00	BASE COMP., CONTROL	1	
16*	16584883300	SPRING, CONTROL ADJUSTING	1	
17*	16592883310	SPRING, CABLE RETURN	1	
19	90013883000	BOLT, FLANGE 6 X 12 CT200	2	
20	90015ZE5010	BOLT, GOVERNOR ARM	1	
21	90114SA0000	NUT, SELF-LOCK 6MM	1	
24*	93500050280A	SCREW, PAN 5 X 28	1	
26*	93500050160A	SCREW, PAN 5 X 16	1	
27	9405006000	NUT, FLANGE 6MM	1	

HONDA GX240K1QA2 ENGINE — CRANKCASE COVER ASSY.

CRANKCASE COVER ASSY.

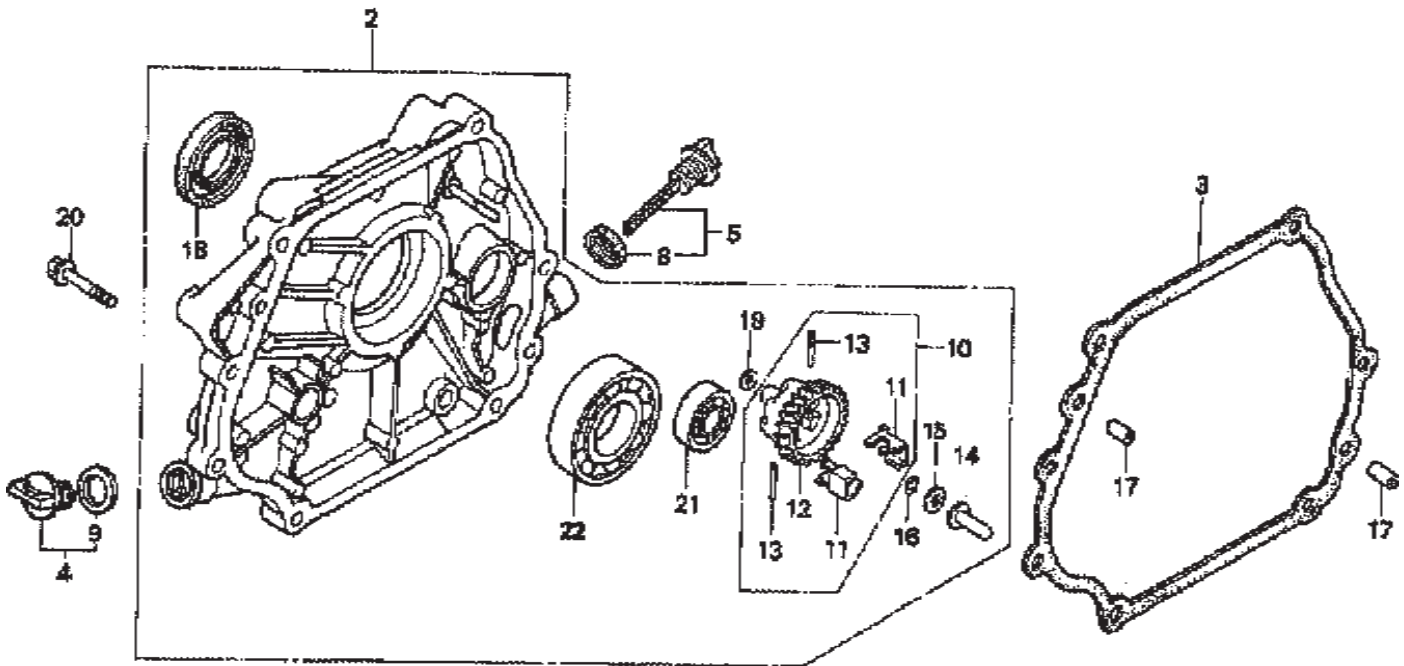

HONDA GX240K1QA2 ENGINE — CRANKCASE COVER ASSY.

CRANKCASE COVER ASSY.

<u>NO.</u>	<u>PART NO.</u>	<u>PART NAME</u>	<u>QTY.</u>	<u>REMARKS</u>
2	11400ZE2601	COVER ASSY., CRANKCASE	1	INCLUDES ITEMS W/*
3	11381ZE2801	GASKET, CASE COVER	1	
4	15600ZG4003	CAP ASSY., OIL FILLER	1	INCLUDES ITEMS W/%
5	15600735003	CAP ASSY., OIL FILLER	1	INCLUDES ITEMS W/+
8+	15625ZE1000	GASKET, OIL FILLER CAP	1	
9%	15625ZE1003	GASKET, OIL FILLER CAP	1	
10*	16510ZE2811	GOVERNOR ASSY., BALANCER	1	INCLUDES ITEMS W/\$
11*\$	16511ZE2000	WEIGHT, GOVERNOR	2	
12*\$	16512ZE2811	HOLDER, GOVERNOR WEIGHT	1	
13*\$	16513ZE2000	PIN, GOVERNOR WEIGHT	2	
14*	16531ZE2000	SLIDER, GOVERNOR	1	
15*	90473147000	WASHER 6 X 16	1	
16*	90602ZE1000	CLIP, GOVERNOR HOLDER	1	
17	90701HC4000	PIN, DOWEL 8 X 12	2	
18*	91201890003	OIL SEAL 30 X 46 X 8	1	
19*	9410106800	WASHER, PLAIN 6MM	1	
20	957010803500	BOLT, FLANGE 8 X 35	7	
21*	961006202000	BEARING, RADIAL BALL 6202	1	
22*	961006206000	BEARING, RADIAL BALL 6206		

HONDA GX240K1QA2 ENGINE — CRANKSHAFT ASSY.

CRANKSHAFT ASSY.

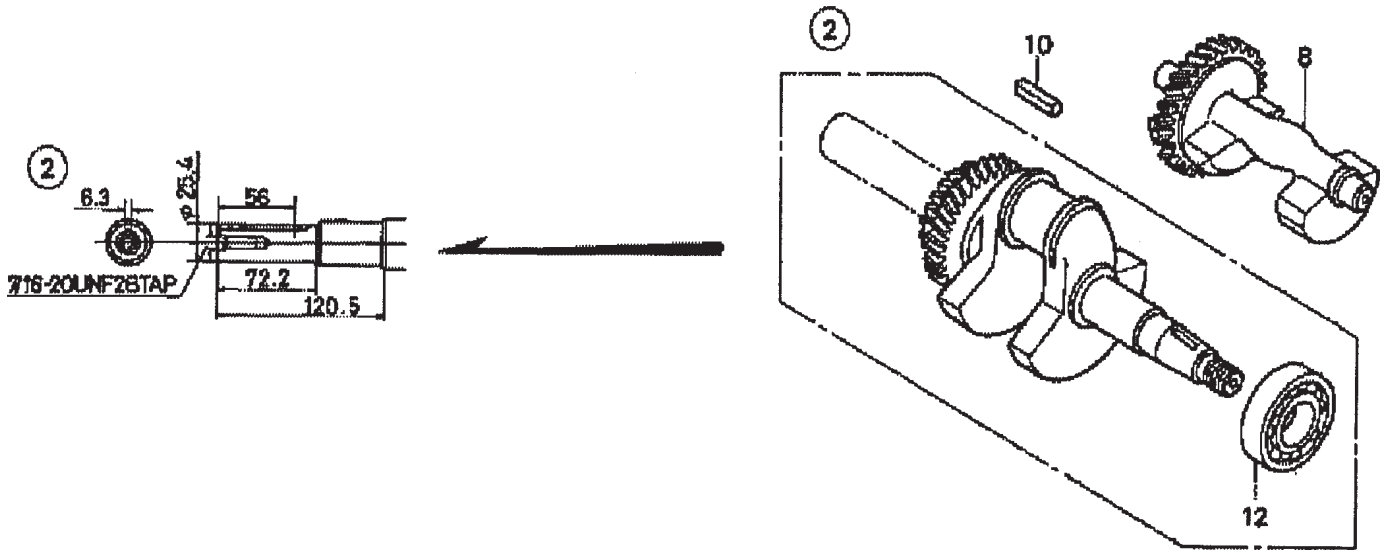

HONDA GX240K1QA2 ENGINE — CRANKSHAFT ASSY.

CRANKSHAFT ASSY.

<u>NO.</u>	<u>PART NO.</u>	<u>PART NAME</u>	<u>QTY.</u>	<u>REMARKS</u>
2	13320ZE2601	CRANKSHAFT COMP., Q- TYPE	1	INCLUDES ITEMS W/*
8	13351ZE2010	WEIGHT, BALANCER	1	
10	90745ZE2600	KEY 6.3 X 6.3 X 43	1	
12*	961006206000	BEARING, RADIAL BALL 6206	1	

HONDA GX240K1QA2 ENGINE — CYLINDER BARREL ASSY.

CYLINDER BARREL ASSY.

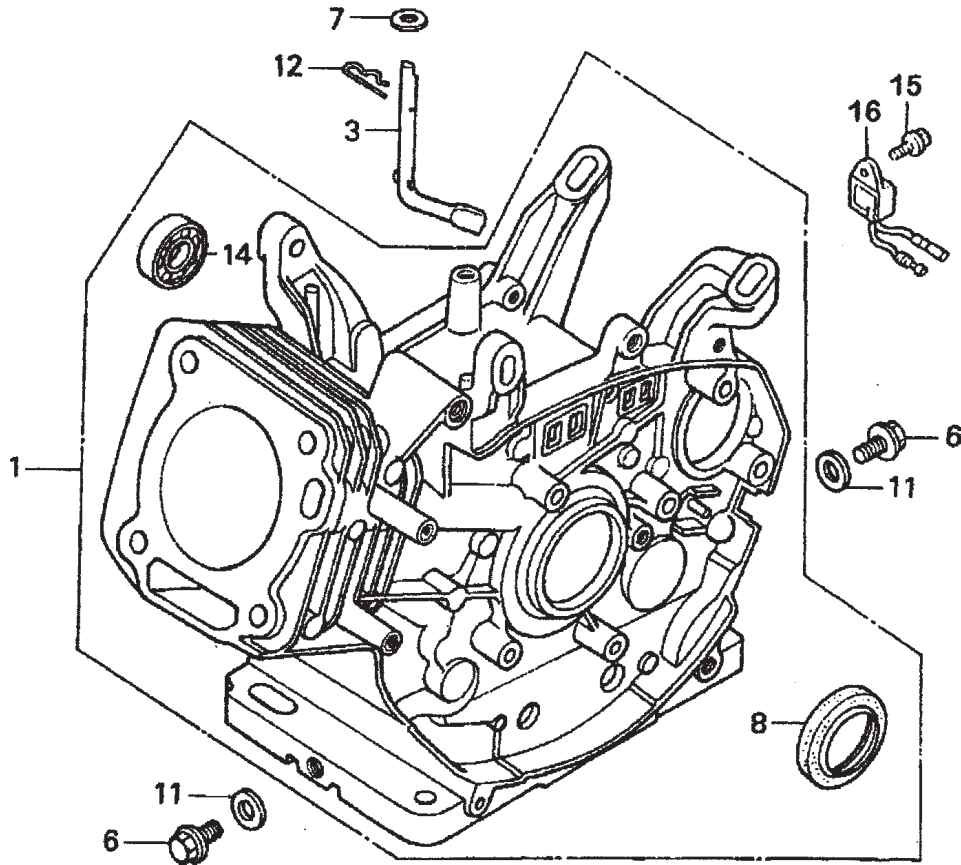

HONDA GX240K1QA2 ENGINE — CYLINDER BARREL ASSY.

CYLINDER BARREL ASSY.

<u>NO.</u>	<u>PART NO.</u>	<u>PART NAME</u>	<u>QTY.</u>	<u>REMARKS</u>
1	12000ZE2834	CYLINDER ASSY., BALANCER + OIL ALERT	1	INCLUDES ITEMS W/*
3	16541ZE2010	SHAFT, GOVERNOR ARM	1	
6	90131896650	BOLT, DRAIN PLUG	2	
7	90446KE1000	WASHER 8.2 X17X0.8	1	
8*	91201890003	OIL SEAL 30X46X8	1	
11	9410912000	WASHER, DRAIN PLUG 12MM	2	
12	9425110000	PIN, LOCK 10MM	1	
14*	961006202000	BEARING, RADIAL BALL 6202	1	
15	90013883000	BOLT, FLANGE 6X12 CT200	1	
16	34150ZH7003	ALERT UNIT, OIL	1	

HONDA GX240K1QA2 ENGINE — CYLINDER HEAD ASSY.

CYLINDER HEAD ASSY.

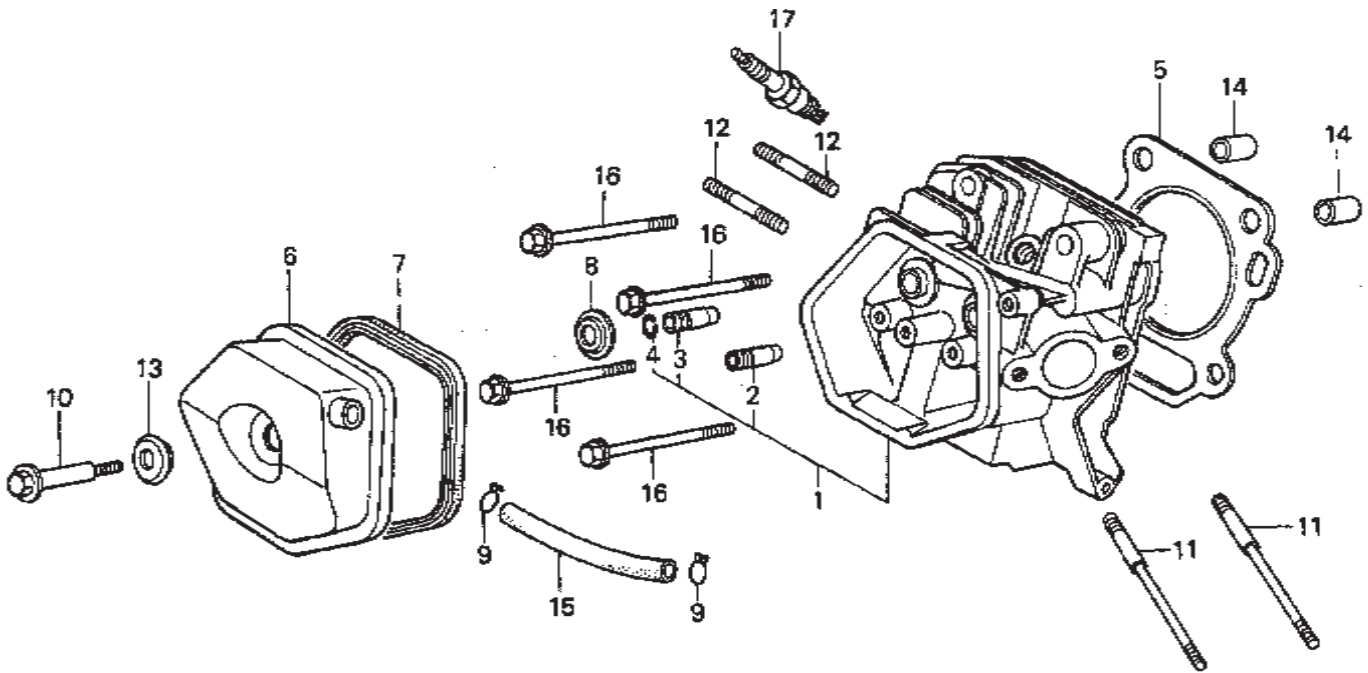

HONDA GX240K1QA2 ENGINE — CYLINDER HEAD ASSY.

CYLINDER HEAD ASSY.

<u>NO.</u>	<u>PART NO.</u>	<u>PART NAME</u>	<u>QTY.</u>	<u>REMARKS</u>
1	12200ZH9000	CYLINDER HEAD COMP.	1	INCLUDES ITEMS W/*
2*	12204ZE2306	GUIDE, VALVE, OS, OPTIONAL	1	
3*	12205ZE2305	GUIDE, EX. VALVE, OS, OPTIONAL	1	
4*	12216ZE2300	CLIP, VALVE GUIDE	1	
5	12251ZE2800	GASKET, CYLINDER HEAD	1	
6	12310ZE2020	COVER COMP., HEAD	1	
7	12391ZE2020	GASKET, CYLINDER HEAD COVER	1	
8	14775ZE2010	SEAT, VALVE SPRING	1	
10	90014ZE2000	BOLT, HEAD COVER	1	
11	90042ZE2000	BOLT, STUD 8X123	2	
12	92900080320E	BOLT 2, STUD 8X32	2	
13	90441ZE2010	WASHER COMP., HEAD COVER	1	
14	9430112200	PIN A, DOWEL 12X20	2	
15	950051100130M	BULK HOSE, VACUUM 11X1000, 11X100	1	
16	957011008000	BOLT, FLANGE 10X80	4	
17	9807955846	SPARK PLUG, BPR5ES, NGK	1	
17	9807955855	SPARK PLUG, W16EPR-U, DENSO, OPTIONAL	1	
17	9807956846	SPARK PLUG, BPR6ES, NGK	1	
17	9807956855	SPARK PLUG, W20EPR-U, DENSO	1	

HONDA GX240K1QA2ENGINE — FAN COVER ASSY.

FAN COVER ASSY.

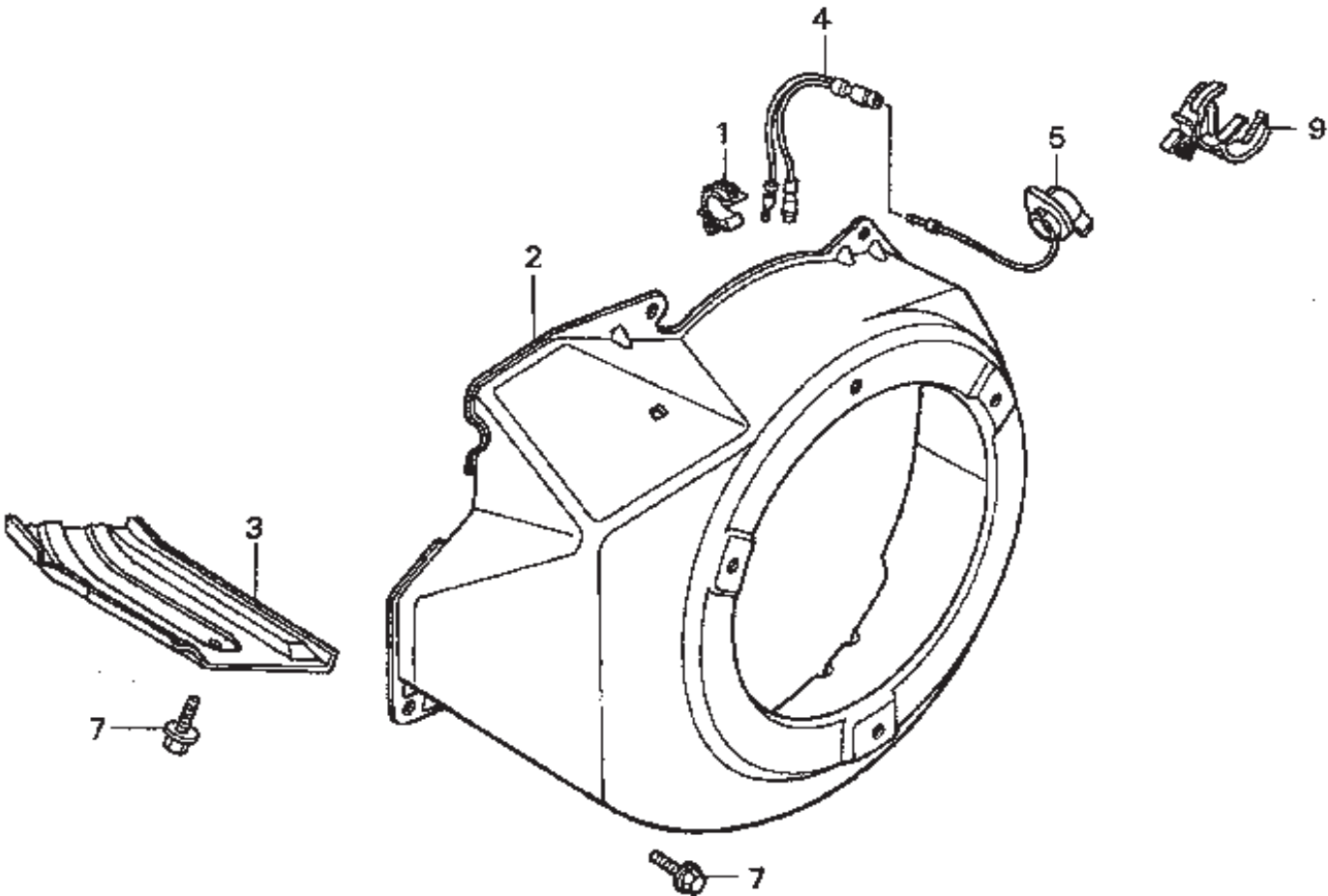

HONDA GX240K1QA2ENGINE — FAN COVER ASSY.

FAN COVER ASSY.

<u>NO.</u>	<u>PART NO.</u>	<u>PART NAME</u>	<u>QTY.</u>	<u>REMARKS</u>
1	16731ZE2003	CLIP, TUBE	1	
2	19610ZE2010ZC	COVER COMP., FAN *NH1* BLACK	1	
3	19631ZE2D00	SHROUD	1	
4	32197ZH8003	SUB-HARNESS	1	
5	36100ZH7003	SWITCH ASSY., ENGINE STOP	1	
7	90013883000	BOLT, FLANGE 6X12, CT200	6	
9	90684ZA0601	CLIP, WIRE HARNESS	1	

HONDA GX240K1QA2 ENGINE — FLYWHEEL ASSY.

FLYWHEEL ASSY.

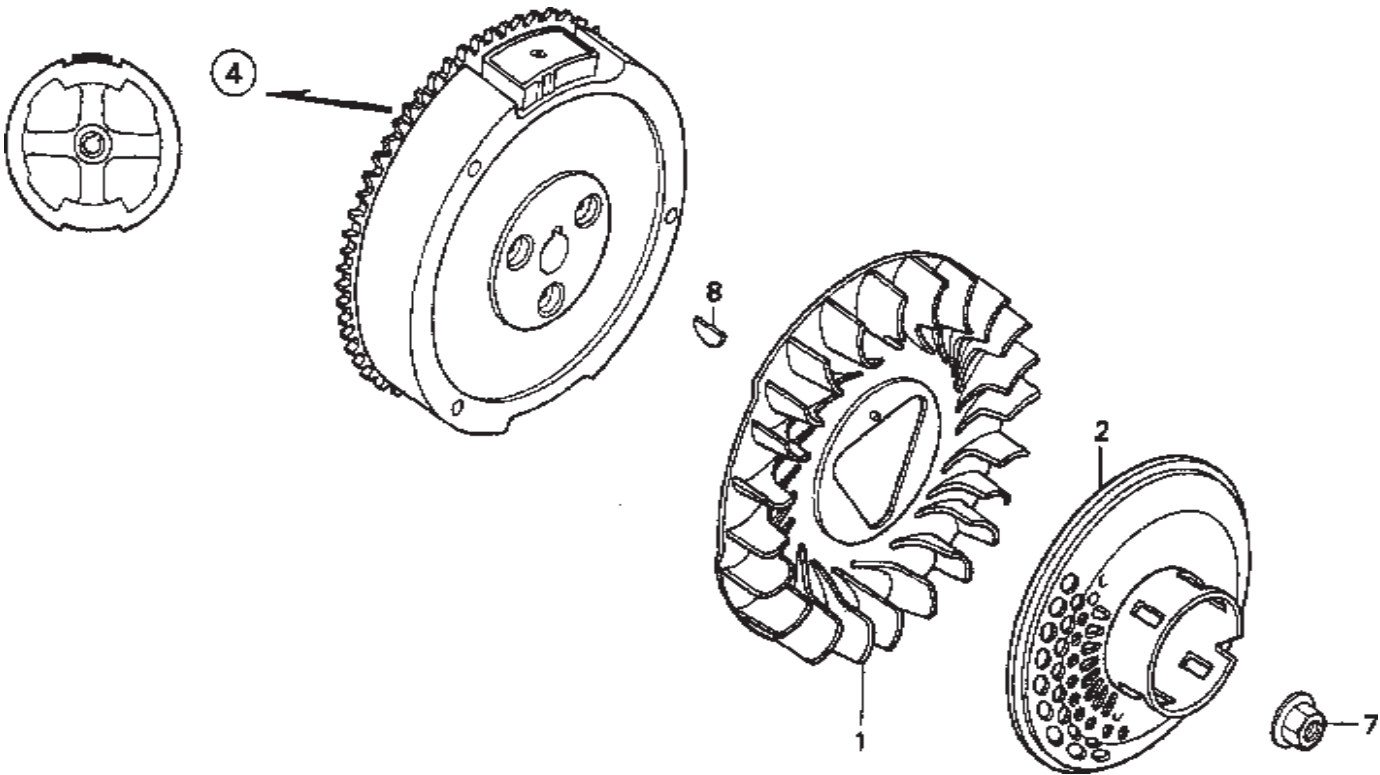

HONDA GX240K1QA2 ENGINE — FLYWHEEL ASSY.

FLYWHEEL ASSY.

<u>NO.</u>	<u>PART NO.</u>	<u>PART NAME</u>	<u>QTY.</u>	<u>REMARKS</u>
1	19511ZE2000	FAN, COOLING	1	
2	28450ZE2W11	PULLEY COMP., STARTER, SCREEN GRID	1	
4	31100ZE2010	FLYWHEEL COMP.	1	
7	90201ZE3V00	NUT, SPECIAL 16MM	1	
8	90741ZE2000	KEY, SPECIAL WOODRUFF 25X18	1	

HONDA GX240K1QA2ENGINE — FUEL TANK ASSY.

FUEL TANK ASSY.

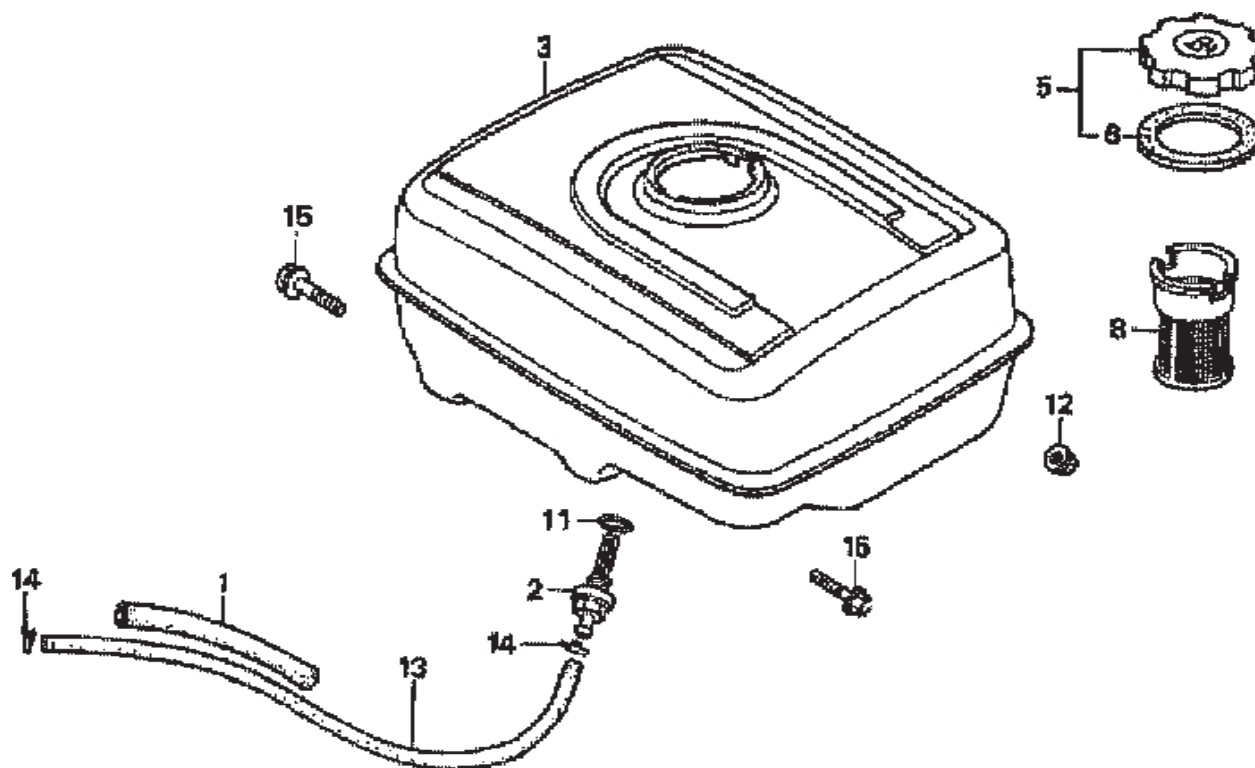

HONDA GX240K1QA2ENGINE — FUEL TANK ASSY.

FUEL TANK ASSY.

<u>NO.</u>	<u>PART NO.</u>	<u>PART NAME</u>	<u>QTY.</u>	<u>REMARKS</u>
1	16854ZH8000	RUBBER SUPPORTER 107MM	1	
2	16955ZE1000	JOINT, FUEL TANK	1	
3	17510ZE2020ZD	TANK COMP., FUEL *NH1*, BLACK	1	
5	17620ZH7023	CAP COMP., FUEL FILLER	1	INCLUDES ITEMS W/*
6*	17631ZH7003	GASKET, FUEL FILLER CAP	1	
8	17672ZE2W01	FILTER, FUEL	1	
11	91353671003	O-RING 14MM, ARAI	1	
12	9405008000	NUT, FLANGE 8MM	2	
13	950014500360M	BULK HOSE, FUEL 4.5X3000, 4.5X222	1	
14	9500202080	CLIP, TUBE, B8	2	
15	957010802500	BOLT, FLANGE 8X25	2	

HONDA GX240K1QA2 ENGINE — IGNITION COIL ASSY.

IGNITION COIL ASSY.

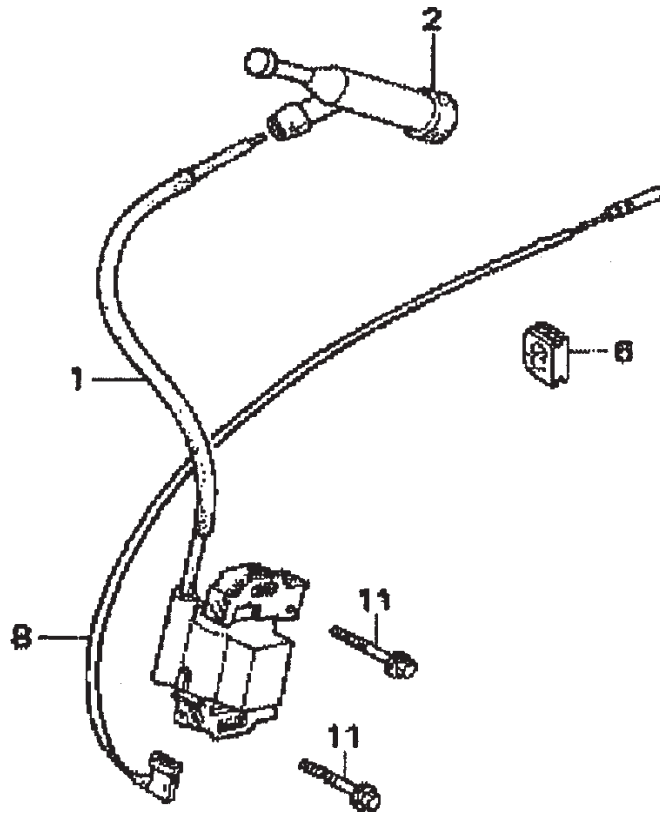

HONDA GX240K1QA2 ENGINE — IGNITION COIL ASSY.

IGNITION COIL ASSY.

<u>NO.</u>	<u>PART NO.</u>	<u>PART NAME</u>	<u>QTY.</u>	<u>REMARKS</u>
1	30500ZE2023	COIL ASSY., IGNITION	1	
2	30700ZE1013	CAP ASSY., NOISE SUPPRESSOR	1	
6	31512ZE2000	GROMMET, WIRE	1	
8	36101ZE1010	WIRE, STOP SWITCH 370MM	1	
11	90015883000	BOLT, FLANGE 6X28	2	

HONDA GX240K1QA2 ENGINE — MUFFLER ASSY.

MUFFLER ASSY.

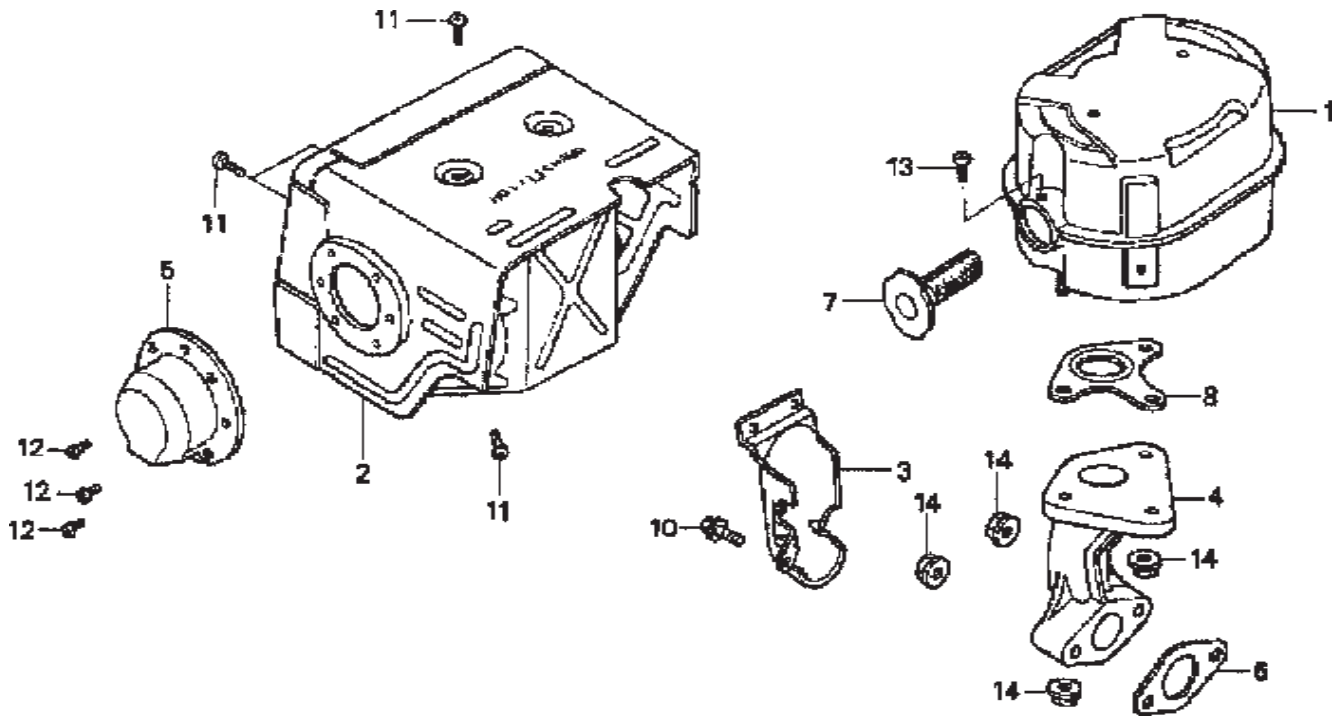

HONDA GX240K1QA2 ENGINE — MUFFLER ASSY.

MUFFLER ASSY.

<u>NO.</u>	<u>PART NO.</u>	<u>PART NAME</u>	<u>QTY.</u>	<u>REMARKS</u>
1	18310ZE2W00	MUFFLER COMP.	1	
2	18320ZE2W01	PROTECTOR COMP., MUFFLER	1	
3	18323ZE2W00	PROTECTOR, EX. PIPE	1	
4	18330ZE2W00	PIPE, EX.	1	
5	18331ZE2810	CAP, MUFFLER	1	
6	18333ZE3800	GASKET, EX. PIPE	1	
7	18355ZE2010	ARRESTER, SPARK	1	
8	18381ZE2W10	GASKET, MUFFLER, ARRESTER	1	
10	90013883000	BOLT, FLANGE 6X12 CT200	1	
11	90050ZE1000	SCREW, TAPPING 5X8	6	
12	90055ZE1000	SCREW, TAPPING 4X6	3	
13	90050ZE1000	SCREW, TAPPING 5X8	1	
14	9405008000	NUT, FLANGE 8MM	5	

HONDA GX240K1QA2 ENGINE — PISTON ASSY.

PISTON ASSY.

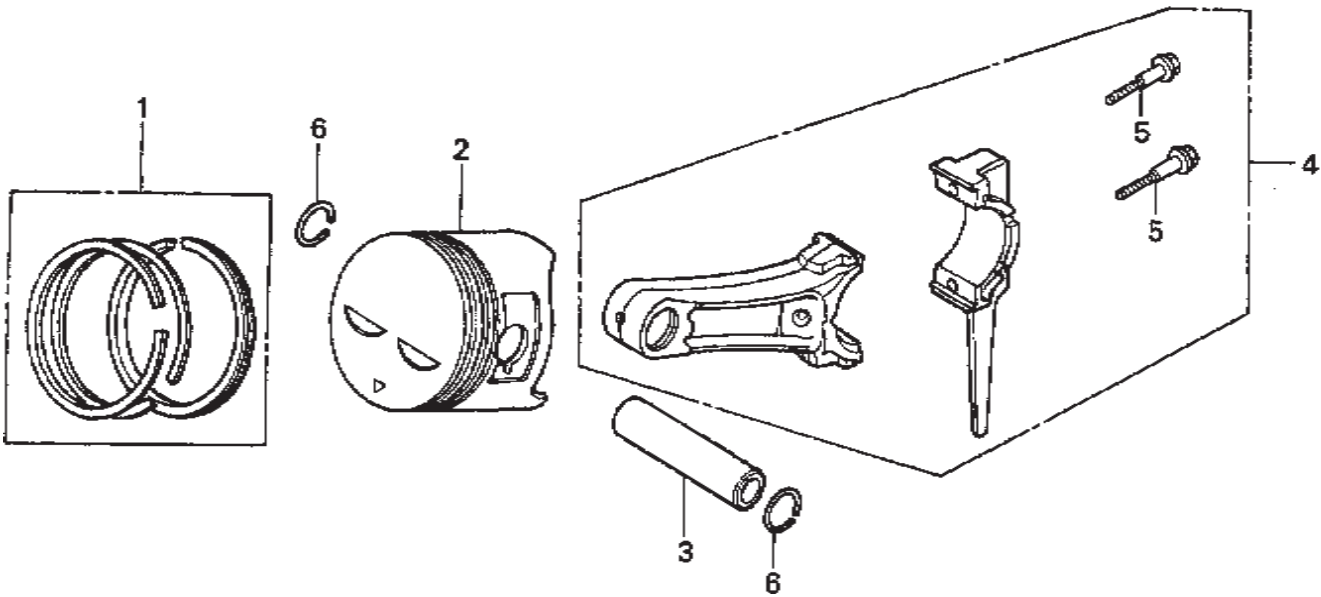

HONDA GX240K1QA2 ENGINE — PISTON ASSY.

PISTON ASSY.

<u>NO.</u>	<u>PART NO.</u>	<u>PART NAME</u>	<u>QTY.</u>	<u>REMARKS</u>
1	13010ZE2013	RING SET, PISTON, STD.	1	
1	13011ZE2013	RING SET, PISTON, OS 0.25, OPTIONAL	1	
1	13012ZE2013	RING SET, PISTON, OS 0.50, OPTIONAL	1	
1	13013ZE2013	RING SET, PISTON, 0.75, OPTIONAL	1	
2	13101ZE2W00	PISTON, STANDARD	1	
2	13102ZE2W00	PISTON, OS 0.25, OPTIONAL	1	
2	13103ZE2W00	PISTON, OS 0.50, OPTIONAL	1	
2	13104ZE2W00	PISTON, 0.75, OPTIONAL	1	
3	13111ZE2000	PIN, PISTON	1	
4	13200ZE2000	ROD ASSY., CONNECTING STANDARD	1	INCLUDES ITEMS W/*
4	13200ZE2305	ROD ASSY., CONNECTING, US 0.25, OPT.	1	INCLUDES ITEMS W/*
5*	90001ZE8000	BOLT, CONNECTING ROD	2	
6	90551ZE1000	CLIP, PISTON PIN 18MM	2	

HONDA GX240K1QA2 ENGINE — RECOIL STARTER ASSY.

RECOIL STARTER ASSY.

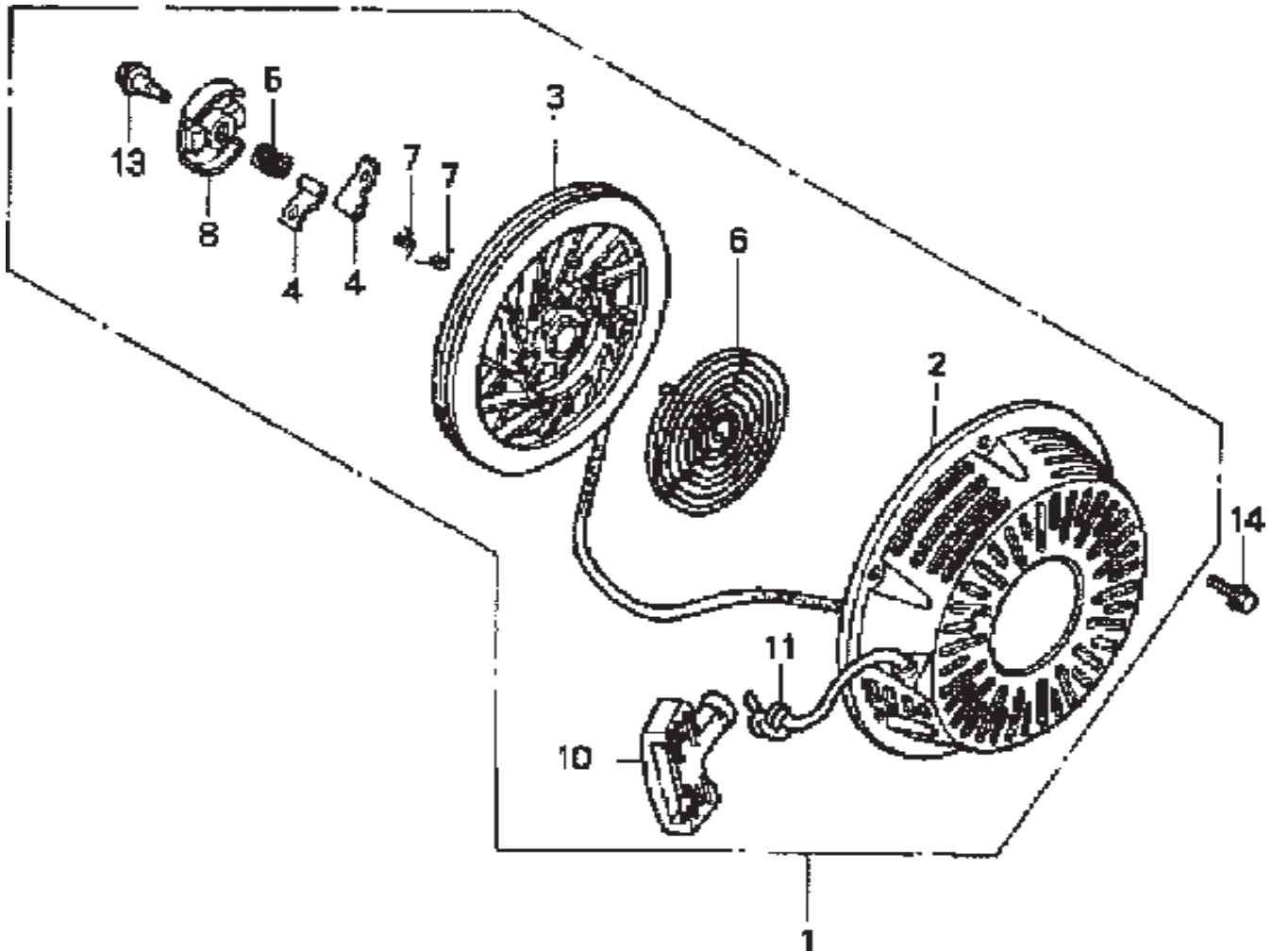

HONDA GX240K1QA2 ENGINE — RECOIL STARTER ASSY.

RECOIL STARTER ASSY.

<u>NO.</u>	<u>PART NO.</u>	<u>PART NAME</u>	<u>QTY.</u>	<u>REMARKS</u>
1	28400ZE2W01ZB	STARTER ASSY., RECOIL *NH1*, BLACK	1	INCLUDES ITEMS W/*
2*	28410ZE2W01ZB	CASE COMP., RECOIL STARTER *NH1*, BLACK	1	
3*	28421ZE2W01	PULLEY, RECOIL STARTER	1	
4*	28422ZE2W01	RATCHET, STARTER	2	
5*	28441ZE2W01	SPRING, FRICTION	1	
6*	28442ZE2W01	SPRING, STARTER RETURN	1	
7*	28443ZE2W01	SPRING RATCHET	2	
8*	28444ZE2W01	RETAINER, SPRING	1	
10*	28461ZE2W02	GRIP, STARTER	1	
11*	28462ZE2W11	ROPE, RECOIL STARTER	1	
13*	90004ZE2W01	SCREW, CENTER	1	
14	90008ZE2003	BOLT, FLANGE 6X10	3	

HONDA GX240K1QA2 ENGINE — ENGINE LABELS

ENGINE LABELS

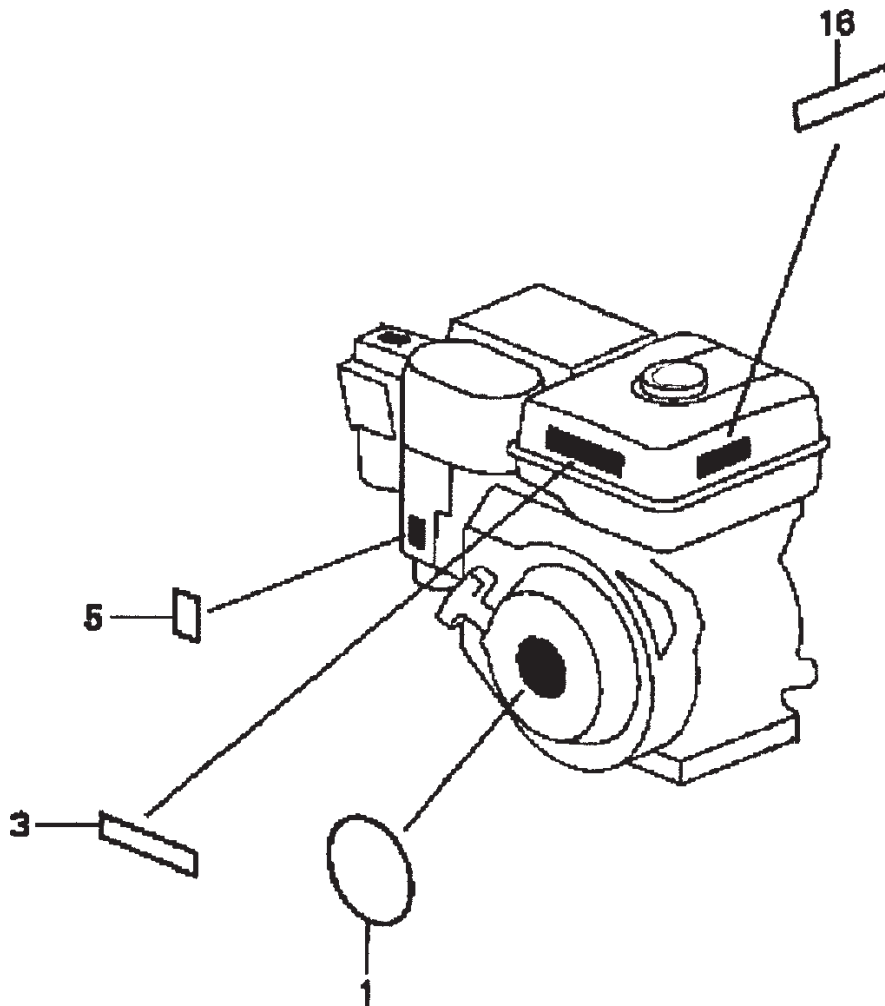

HONDA GX240K1QA2 ENGINE — ENGINE LABELS

ENGINE LABELS

<u>NO.</u>	<u>PART NO.</u>	<u>PART NAME</u>	<u>QTY.</u>	<u>REMARKS</u>
1	87521ZE2W01	EMBLEM, INTERNAL	1	
3	87522ZH9000	LABEL, CAUTION	1	
5	87528ZE2810	MARK, CHOKE, EXTERNAL	1	
16	87532ZH8810	MARK, OIL ALERT, E	1	

HONDA GX-340K1QAP2 ENGINE — AIR CLEANER ASSY.

AIR CLEANER ASSY.

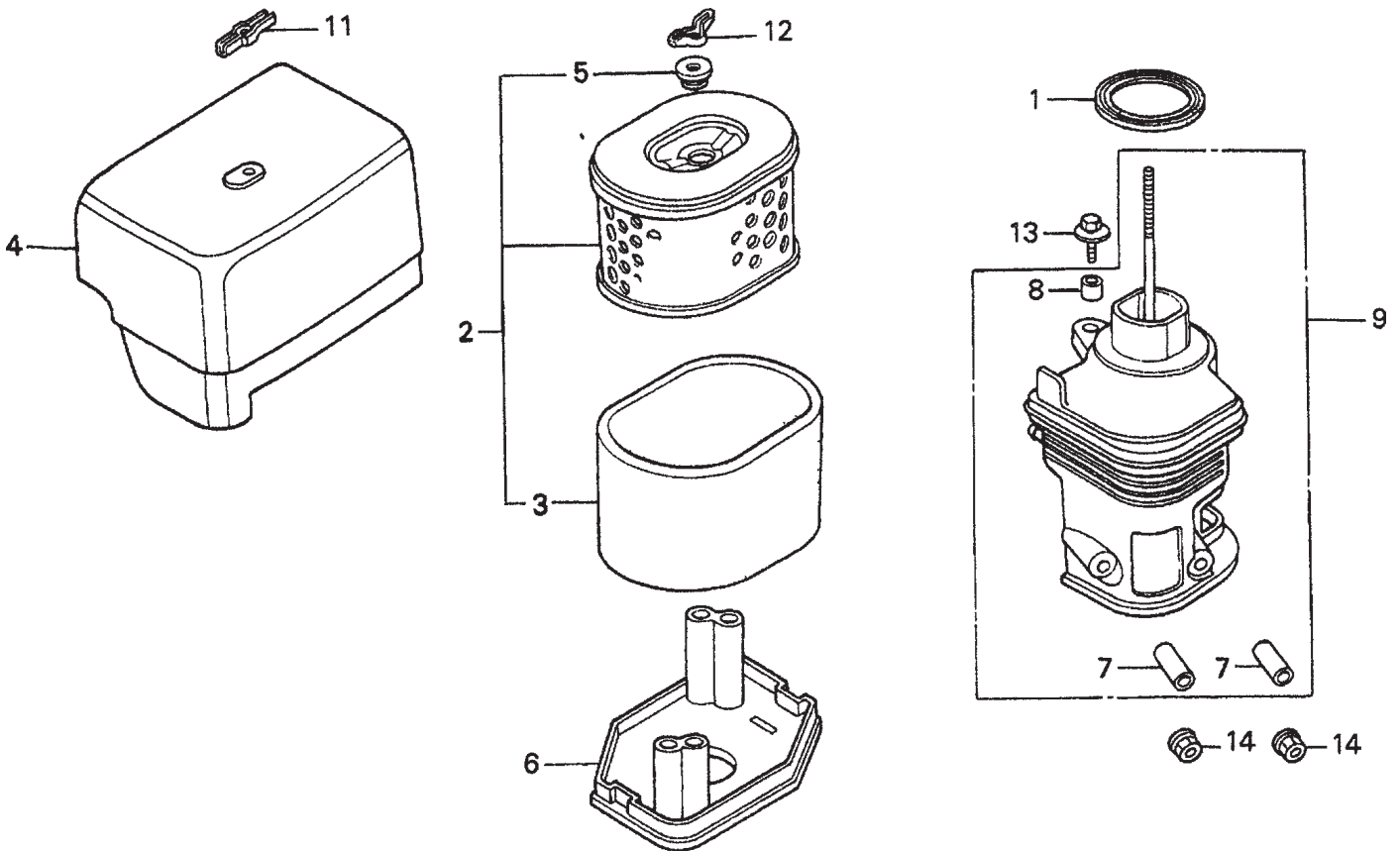

HONDA GX-340K1QAP2 ENGINE — AIR CLEANER ASSY.

AIR CLEANER ASSY.

<u>NO.</u>	<u>PART NO.</u>	<u>PART NAME</u>	<u>QTY.</u>	<u>REMARKS</u>
1	16271ZE2000	GASKET, ELBOW	1	
2	17210ZE3505	ELEMENT, AIR CLEANER.....	1	INCLUDES ITEMS W/*
3*	17218ZE3505	FILTER, OUTER	1	
4	17231ZE3W00	COVER, AIR CLEANER	1	
5*	17232891000	GROMMET, AIR CLEANER	1	
6	17235ZH9N00	NOSE, MUFFLER	1	
7#	17238ZE2310	COLLAR, AIR CLEANER	2	
8#	17239ZE1000	COLLAR B, AIR CLEANER	1	
9	17410ZH9N00	ELBOW, AIR CLEANER	1	INCLUDES ITEMS W/#
11	90203ZA0800	WINGNUT 6MM	1	
12	90325044000	WINGNUT, TOOL BOX SETTING	1	
13	934040602008	BOLT- WASHER 6 X 20	1	
14	9405006000	NUT, FLANGE 6MM	2	

HONDA GX-340K1QAP2 ENGINE — CAMSHAFT ASSY.

CAMSHAFT ASSY.

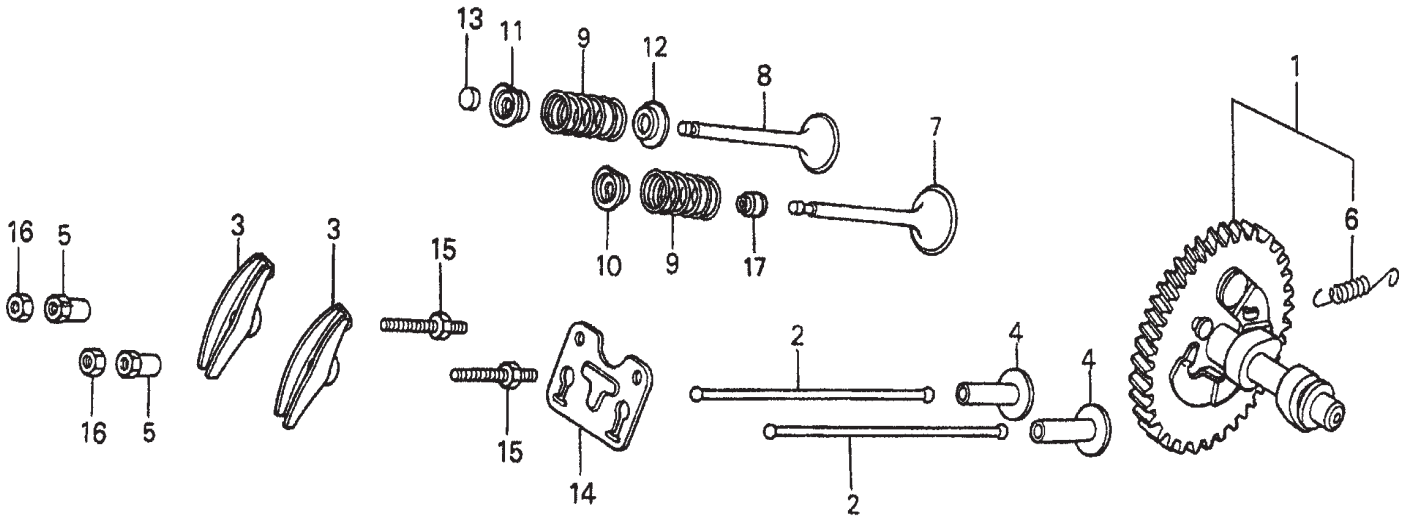

HONDA GX-340K1QAP2 ENGINE — CAMSHAFT ASSY.

CAMSHAFT ASSY.

<u>NO.</u>	<u>PART NO.</u>	<u>PART NAME</u>	<u>QTY.</u>	<u>REMARKS</u>
1	14100ZE3020	CAMSHAFT ASSEMBLY	1	INCLUDES ITEM W/*
2	14410ZE3013	ROD, PUSH	2	
3	14431ZE2010	ARM, VALVE ROCKER	2	
4	14441ZE2000	LIFTER, VALVE	2	
5	14451ZE1013	PIVOT, ROCKER ARM	2	
6*	14568ZE1000	SPRING, WEIGHT RETURN	1	
7	14711ZE3000	VALVE, INTAKE	1	
8	14721ZE3000	VALVE, EXHAUST	1	
9	14751ZE2003	SPRING, VALVE	2	
10	14771ZE2000	RETAINER, INTAKE VALVE SPRING	1	
11	14773ZE2000	RETAINER, EXHAUST VALVE SPRING	1	
12	14775ZE2010	SEAT, VALVE SPRING	1	
13	14781ZE2000	ROTATOR, VALVE	1	
14	14791ZE2010	PLATE, PUSH ROD GUIDE	1	
15	90012ZE0010	BOLT, PIVOT 8MM	2	
16	90206ZE1000	NUT, PIVOT ADJ.	2	
17	12209ZE8003	SEAL, VALVE STEM	1	

HONDA GX-340K1QAP2 ENGINE — CARBURETOR ASSY.

CARBURETOR ASSY.

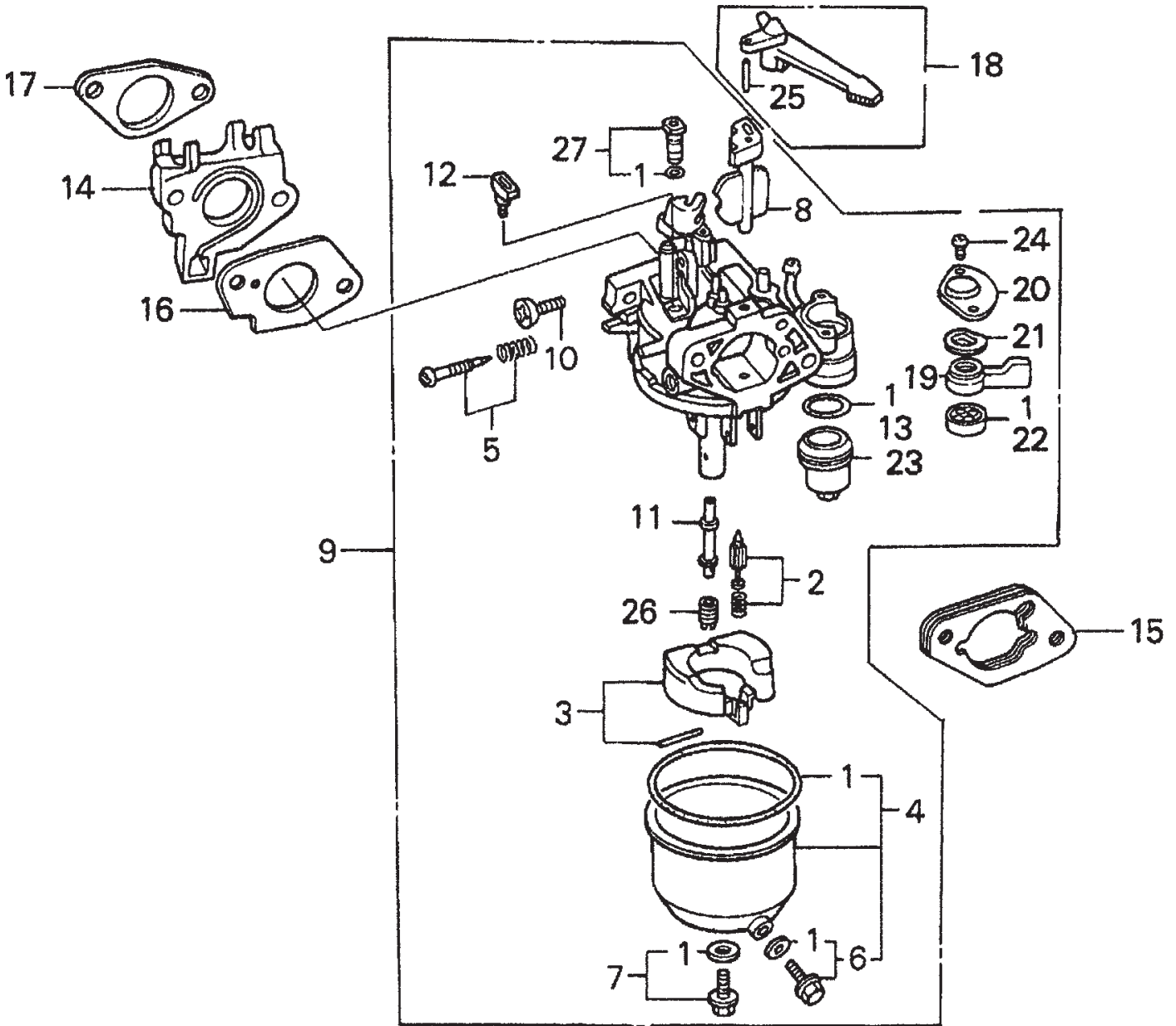

HONDA GX-340K1QAP2 ENGINE — CARBURETOR ASSY.

CARBURETOR ASSY.

<u>NO.</u>	<u>PART NO.</u>	<u>PART NAME</u>	<u>QTY.</u>	<u>REMARKS</u>
1*	16010ZE2812	GASKET SET	1	
2*	16011ZA0931	VALVE SET, FLOAT	1	
3*	16013ZA0931	FLOAT SET	1	
4*	16015ZE8005	CHAMBER SET, FLOAT	1	
5*	16016ZH7W01	SCREW SET	1	
6*	16024ZE1811	SCREW SET, DRAIN	1	
7*	16028ZE0005	SCREW SET B	1	
8*	16044ZE3811	CHOKE SET	1	
9*	16100ZE3V01	CARBURETOR ASSEMBLY (BE80B B)	1	INCLUDES ITEMS W/*
10*	16124ZE0005	SCREW, THROTTLE STOP	1	
11*	16166ZE3W50	NOZZLE, MAIN	1	
12*	16172ZE3W10	COLLAR, SET	1	
13*	16173001004	GASKET, FUEL STRAINER CUP	1	
14	16211ZE3000	INSULATOR, CARBURETOR	1	
15	16220ZA0702	SPACER, CARBURETOR	1	
16	16221ZE3800	GASKET, CARBURETOR	1	
17	16223ZE3800	GASKET, INSULATOR	1	
18	16610ZE1000	LEVER, CHOKE (STANDARD)	1	INCLUDES ITEM W/#
19*	16953ZE1812	LEVER, VALVE	1	
20*	16954ZE1812	PLATE, LEVER SETTING	1	
21*	16956ZE1811	SPRING, VALVE LEVER	1	
22*	16957ZE1812	GASKET, VALVE	1	
23*	16967ZE0811	CUP, FUEL STRAINER	1	
24*	93500030060H	SCREW, PAN 3 X 6	2	
25#	9430520122	PIN, SPRING 2 X12	1	
26*	99101ZH70880	JET, MAIN #88 (OPTIONAL)	1	
26*	99101ZH80800	JET, MAIN #90 (OPTIONAL)	1	
26*	99101ZH80920	JET, MAIN #92	1	
27*	99204ZE00350	JET SET, PILOT #35	1	

HONDA GX-340K1QAP2 ENGINE — CRANKCASE COVER ASSY.

CRANKCASE COVER ASSY.

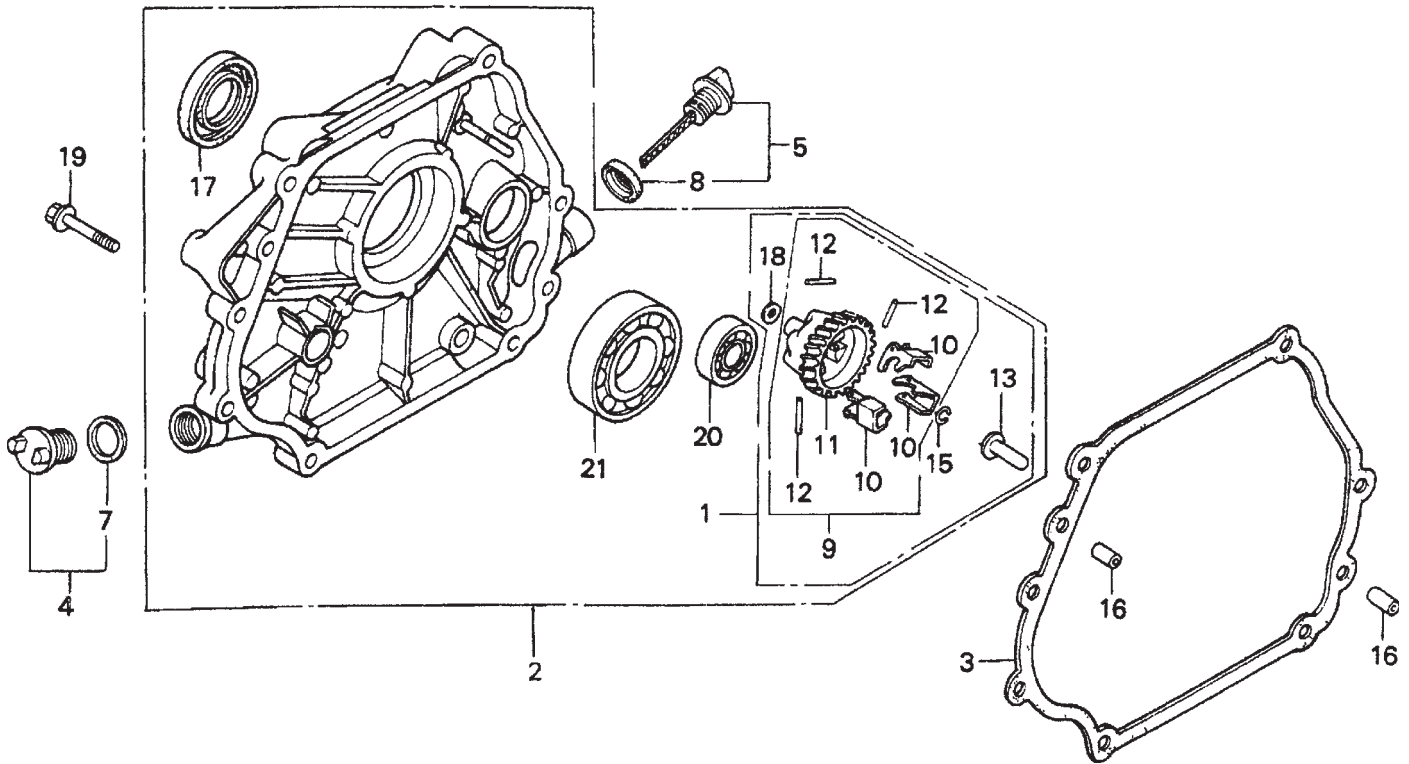

HONDA GX-340K1QAP2 ENGINE — CRANKCASE COVER ASSY.

CRANKCASE COVER ASSY.

<u>NO.</u>	<u>PART NO.</u>	<u>PART NAME</u>	<u>QTY.</u>	<u>REMARKS</u>
1	06165ZE3000	GOVERNOR KIT (OPTIONAL)	1	INCLUDES ITEMS W/♣
2	11300ZE3602	COVER ASSY., CRANKCASE (Q TYPE)	1	INCLUDES ITEMS W/\$
3	11381ZE3801	GASKET, CASE COVER	1	
4	15600ZG4003	CAP ASSEMBLY, OIL FILLER	1	INCLUDES ITEMS W/*
5	15600735003	CAP ASSEMBLY, OIL FILLER	1	INCLUDES ITEMS W/%
7*	15625ZE1003	GASKET, OIL FILLER CAP	1	
8%	15625ZE1003	GASKET, OIL FILLER CAP	1	
9\$	16510ZE3000	GOVERNOR ASSEMBLY	1	INCLUDES ITEMS W/#
10#♣\$	16511ZE8000	WEIGHT, GOVERNOR	3	
11#♣\$	16512ZE3000	HOLDER, GOVERNOR WEIGHT	1	
12#♣\$	16513ZE2000	PIN, GOVERNOR WEIGHT	3	
13♣\$	16531ZE2000	SLIDER, GOVERNOR	1	
15♣\$	90602ZE1000	CLIP, GOVERNOR HOLDER	1	
16	90701HC4000	PIN, DOWEL 8X12	2	
17\$	91201ZE3004	OIL SEAL 35X52X8	1	
18♣\$	9410106800	WASHER, PLAIN 6MM	1	
19	957010804000	BOLT, FLANGE 8X40	7	
20\$	961006202000	BEARING, RADIAL BALL 6202	1	
21\$	961006207000	BEARING, RADIAL BALL 6207	1	

CONTROL ASSY.

**NO ART WORK
AVAILABLE**

HONDA GX-340K1QAP2 ENGINE — CONTROL ASSY.

CONTROL ASSY.

<u>NO.</u>	<u>PART NO.</u>	<u>PART NAME</u>	<u>QTY.</u>	<u>REMARKS</u>
2	16551ZE3000	ARM, GOVERNOR	1	
3	16555ZE3000	ROD, GOVERNOR	1	
4	16561ZE3000	SPRING, GOVERNOR	1	
5	16562ZE3000	SPRING, THROTTLE RETURN	1	
6	16570ZE3W10	CONTROL ASSEMBLY (REMOTE)	1	
8	16571ZE3W00	LEVER, CONTROL	1	
9	16574ZE1000	SPRING, LEVER	1	
10	16575ZE2W00	WASHER CONTROL LEVER	1	
11	16576891000	HOLDER, CABLE	1	
12	16578ZE1000	SPACER, CONTROL LEVER	1	
14	16584883300	SPRING, CONTROL ADJUSTING	1	
15	16592883310	SPRING, CABLE RETURN	1	
16	16594883010	HOLDER, WIRE	1	
17	90013883000	BOLT, FLANGE 6X12	2	
18	90015ZE5010	BOLT, GOVERNOR ARM	1	
19	90114SA0000	NUT, SELF- LOCK 6MM	1	
20	90605230000	CIRCLIP 5MM	1	
21	93500040060H	SCREW, PAN 4X6	1	
22	93500050320A	SCREW, PAN 5X32	1	
23	93500050160A	SCREW, PAN 5X16	1	
24	9405006000	NUT, FLANGE 6MM	1	

HONDA GX-340K1QAP2 ENGINE — CYLINDER BARREL ASSY.

CYLINDER BARREL ASSY.

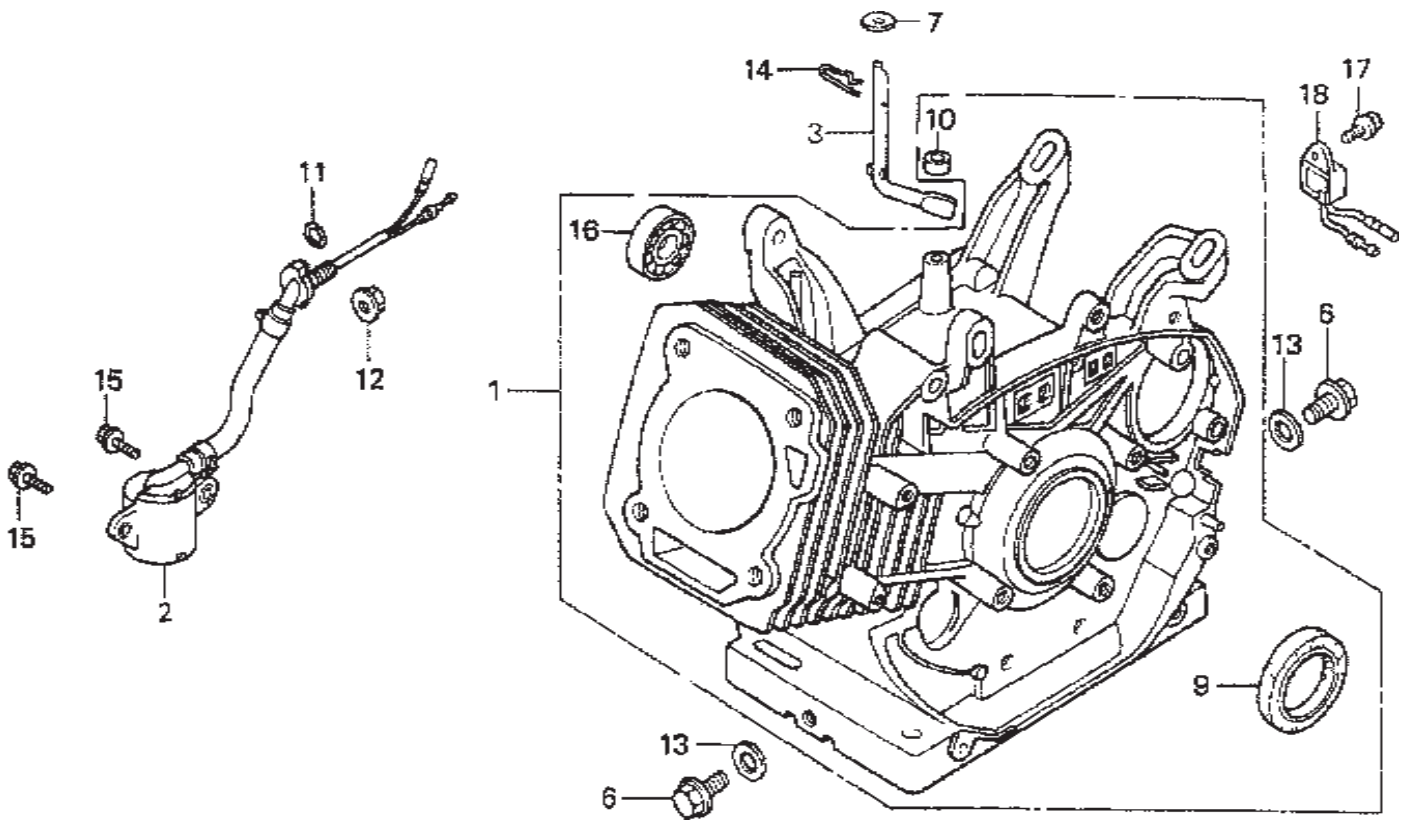

HONDA GX-340K1QAP2 ENGINE — CYLINDER BARREL ASSY.

CYLINDER BARREL ASSY.

<u>NO.</u>	<u>PART NO.</u>	<u>PART NAME</u>	<u>QTY.</u>	<u>REMARKS</u>
1	12000ZE3816	CYLINDER ASSEMBLY	1	INCLUDES ITEMS W/*
2	15510ZE2043	SWITCH ASSEMBLY OIL LEVEL	1	
3	16541ZE3010	SHAFT, GOVERNOR ARM	1	
6	90131896650	BOLT, DRAIN PLUG	2	
7	90446KE1000	WASHER 8.2X17X0.8	1	
9*	91201ZE3004	OIL SEAL 35X52X8	1	
10*	91201ZE9003	OIL SEAL 8X14X5	1	
11	91353671003	O- RING 13.5X1.5 (ARAI)	1	
12	9405010000	NUT, FLANGE 10MM	1	
13	9410912000	WASHER, DRAIN PLUG 12MM	2	
14	9425110000	PIN, LOCK 10MM	1	
15	957010601200	BOLT, FLANGE 6X12	2	
16*	961006202000	BEARING, RADIAL BALL 6202	1	
17	90013883000	BOLT, FLANGE 6X12 (CT200)	1	
18	34150ZH7003	ALERT UNIT, OIL	1	

HONDA GX-340K1QAP2 ENGINE — CYLINDER HEAD ASSY.

CYLINDER HEAD ASSY.

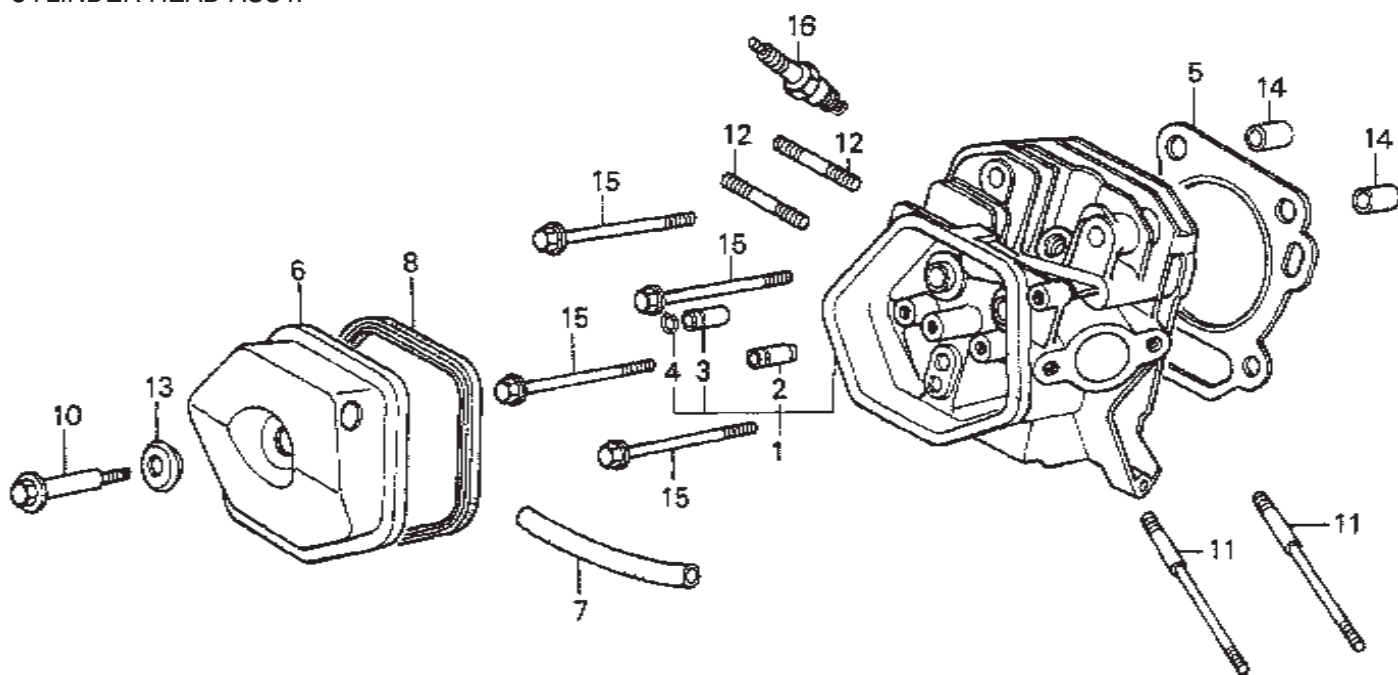

HONDA GX-340K1QAP2 ENGINE — CYLINDER HEAD ASSY.

CYLINDER HEAD ASSY.

<u>NO.</u>	<u>PART NO.</u>	<u>PART NAME</u>	<u>QTY.</u>	<u>REMARKS</u>
1	12200ZF6W00	CYLINDER HEAD	1	INCLUDES ITEMS W/*
2*	12204ZE2306	GUIDE, VALVE OS (OPTIONAL)	1	
3*	12205ZE2305	GUIDE, EX. VALVE OS (OPTIONAL)	1	
4*	12216ZE2300	CLIP, VALVE GUIDE	1	
5	12251ZE3W00	GASKET, CYLINDER HEAD	1	
6	12310ZE3791	COVER, HEAD	1	
7	12315ZE3840	TUBE, BREATHER	1	
8	12391ZE2020	GASKET, CYLINDER HEAD COVER	1	
10	90014ZE2000	BOLT, HEAD COVER	1	
11	90042ZE8000	BOLT, STUD 8X131.5	2	
12	92900080320E	BOLT 2, STUD 8X32	2	
13	90441ZE2010	WASHER, HEAD COVER	1	
14	9430112200	PIN A, DOWEL 12X20	2	
15	957011008000	BOLT, FLANGE 10X80	4	
16	9807956846	SPARK PLUG BPR6ES (NGK)	1	

HONDA GX-340K1QAP2 ENGINE — CRANKSHAFT ASSY.

CRANKSHAFT ASSY.

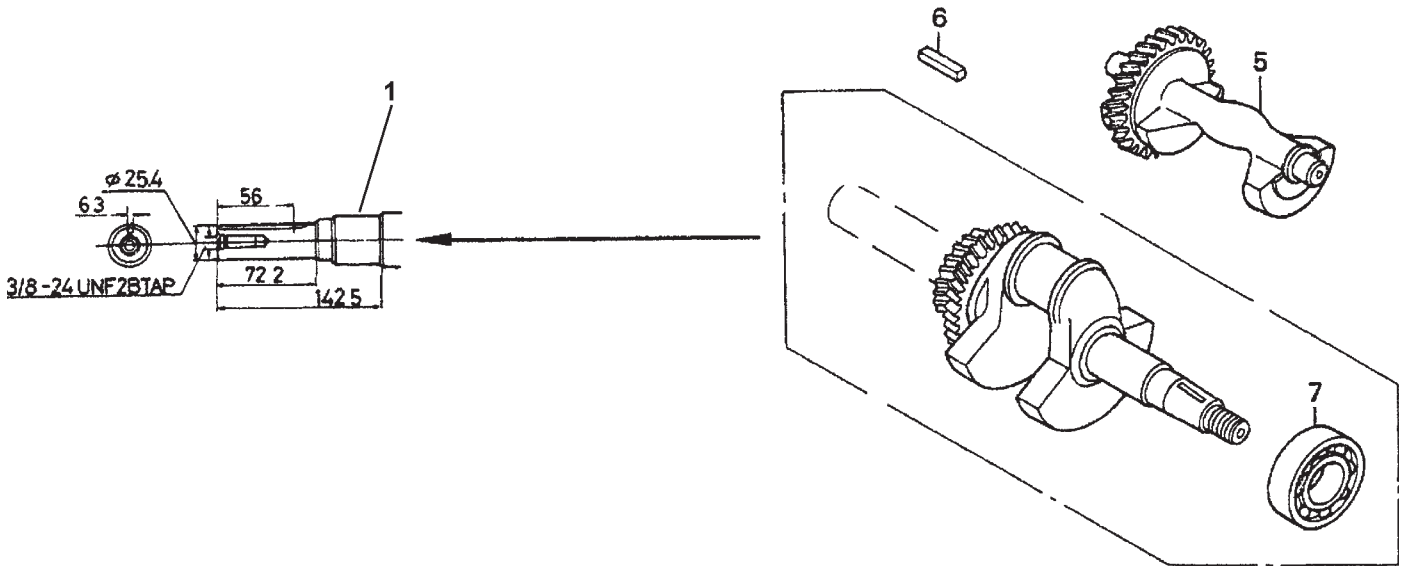

HONDA GX-340K1QAP2 ENGINE — CRANKSHAFT ASSY.

CRANKSHAFT ASSY.

<u>NO.</u>	<u>PART NO.</u>	<u>PART NAME</u>	<u>QTY.</u>	<u>REMARKS</u>
1	13310ZE3601	CRANKSHAFT, Q- TYPE	1	INCLUDES ITEM W/*
5	13351ZE3010	WEIGHT, BALANCER	1	
6	90745ZE2600	KEY 6.3X6.3X43	1	
7*	961006207000	BEARING, RADIAL BALL 6207	1	

HONDA GX-340K1QAP2 ENGINE — FAN COVER ASSY.

FAN COVER ASSY.

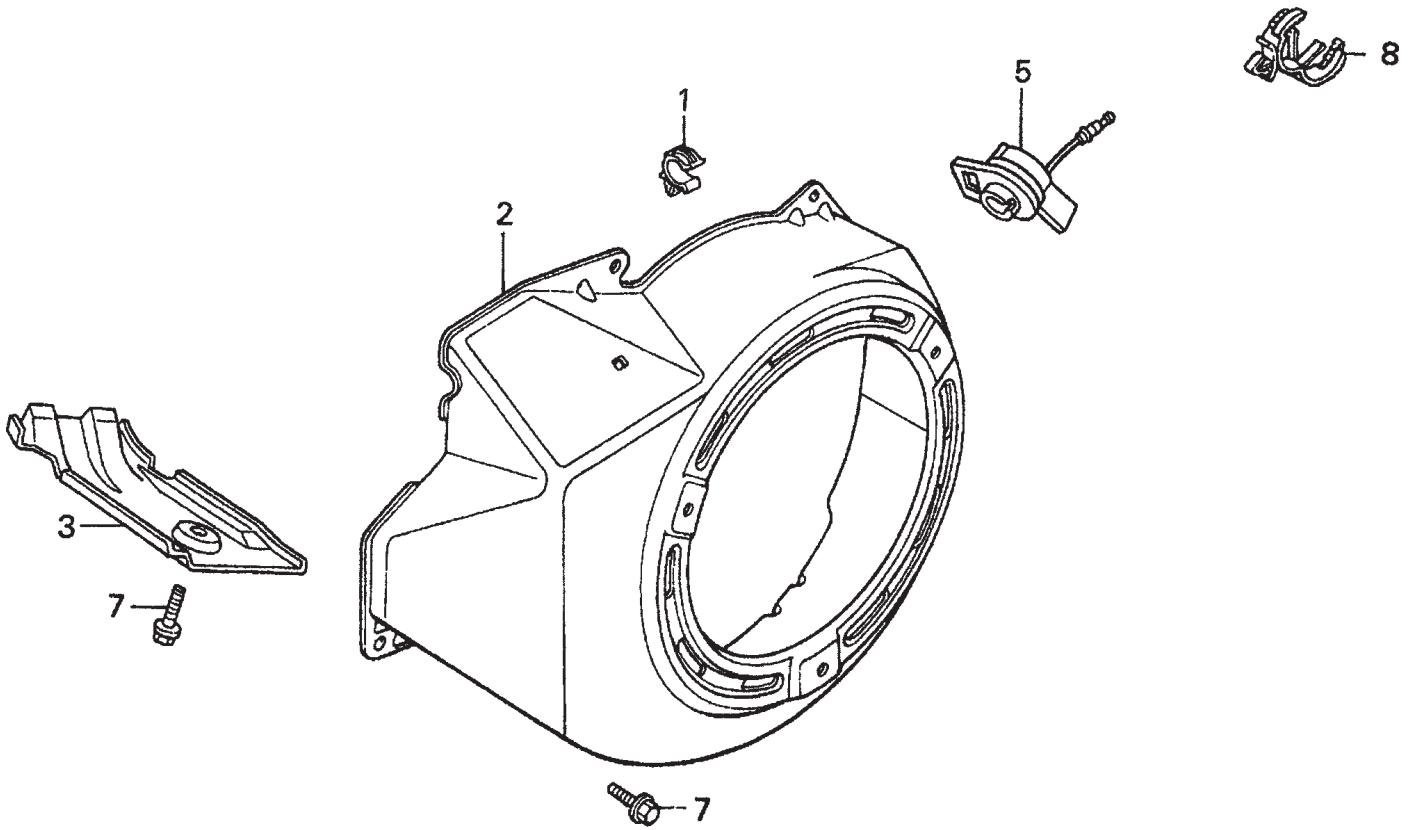

HONDA GX-340K1QAP2 ENGINE — FAN COVER ASSY.

FAN COVER ASSY.

<u>NO.</u>	<u>PART NO.</u>	<u>PART NAME</u>	<u>QTY.</u>	<u>REMARKS</u>
1	16731ZE2003	CLIP, TUBE	1	
2	19610ZE3010ZB	COVER, FAN *NH1* (BLACK)	1	
3	19631ZE3W00	SHROUD	1	
5	36100ZH7003	SWITCH ASSEMBLY, ENGINE STOP	1	
7	90013883000	BOLT, FLANGE 6X12 (CT200)	6	
8	90684ZA0601	CLIP, WIRE HARNESS	1	

HONDA GX-340K1QAP2 ENGINE — FLYWHEEL ASSY.

FLYWHEEL ASSY.

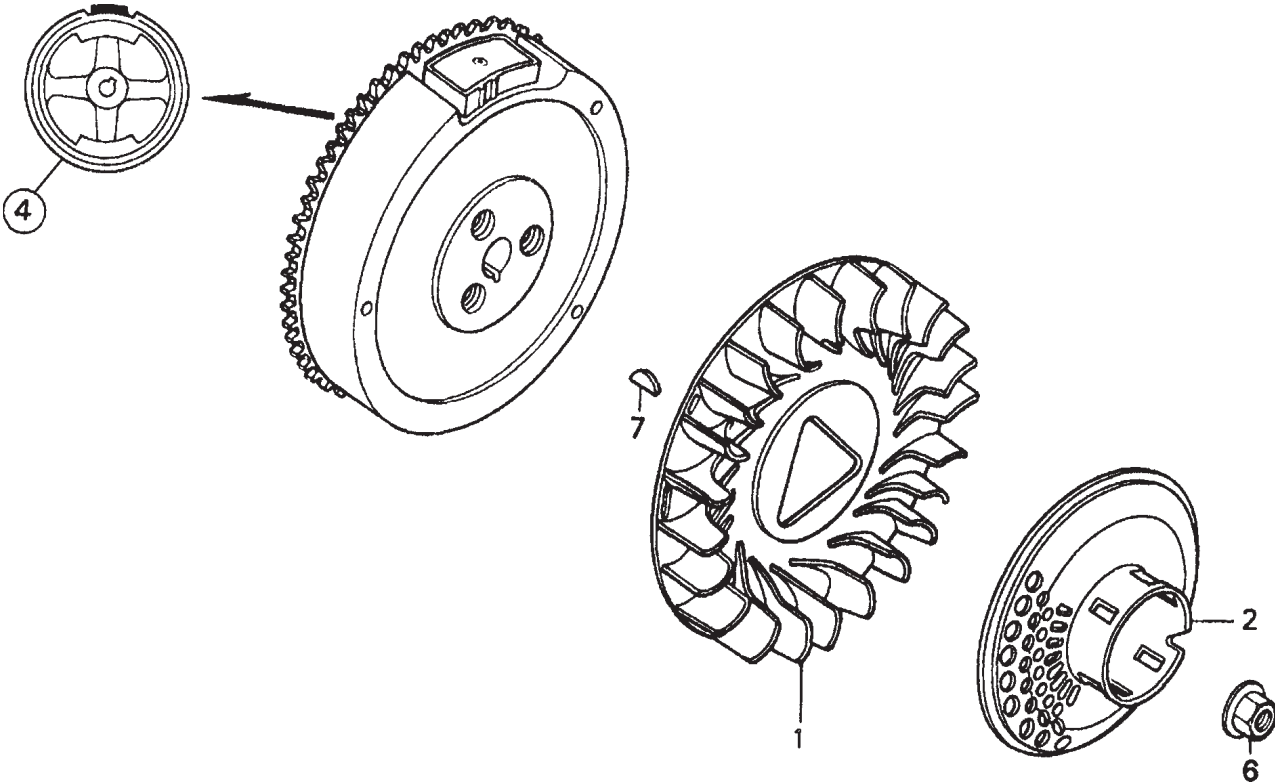

HONDA GX-340K1QAP2 ENGINE — FLYWHEEL ASSY.

FLYWHEEL ASSY.

<u>NO.</u>	<u>PART NO.</u>	<u>PART NAME</u>	<u>QTY.</u>	<u>REMARKS</u>
1	19511ZE3000	FAN, COOLING	1	
2	28450ZE3W11	PULLEY, STARTER (SCREEN GRID)	1	
4	31100ZE3701	FLYWHEEL	1	
6	90201ZE3V00	NUT, SPECIAL 16MM	1	
7	90741ZE2000	KEY, SPECIAL WOODRUFF 25X18	1	

HONDA GX-340K1QAP2 ENGINE — FUEL TANK ASSY.

FUEL TANK ASSY.

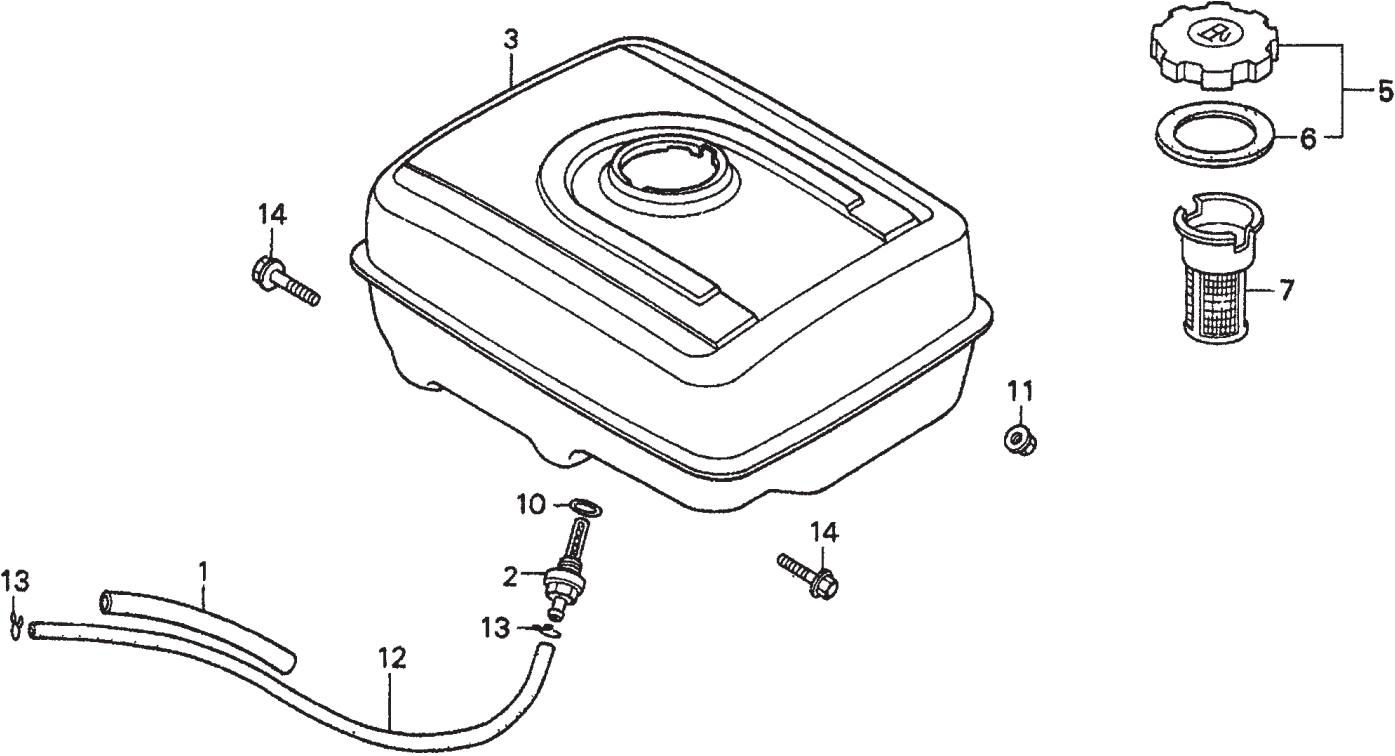

HONDA GX-340K1QAP2 ENGINE — FUEL TANK ASSY.

FUEL TANK ASSY.

<u>NO.</u>	<u>PART NO.</u>	<u>PART NAME</u>	<u>QTY.</u>	<u>REMARKS</u>
1	16854ZH8000	RUBBER, SUPPORTER 107MM	1	
2	16955ZE1000	JOINT FUEL TANK	1	
3	17510ZE3010ZB	TANK, FUEL "NH1" (BLACK)	1	
5	17620ZH7023	CAP, FUEL FILLER	1	INCLUDES ITEM W/*
6*	17631ZH7993	GASKET, FUEL FILLER CAP	1	
7	17672ZE2W01	FILTER, FUEL	1	
10	91353671003	O- RING 13.5X1.5 (ARAI)	1	
11	9405008000	NUT, FLANGE 8MM	2	
12	950014500360M	BULK HOSE, FUEL (4.5X3000) (4.5X235)	1	
13	9500202080	CLIP, TUBE B8	2	
14	957010802500	BOLT, FLANGE 8X25	2	

HONDA GX-340K1QAP2 ENGINE — IGNITION COIL ASSY.

IGNITION COIL ASSY.

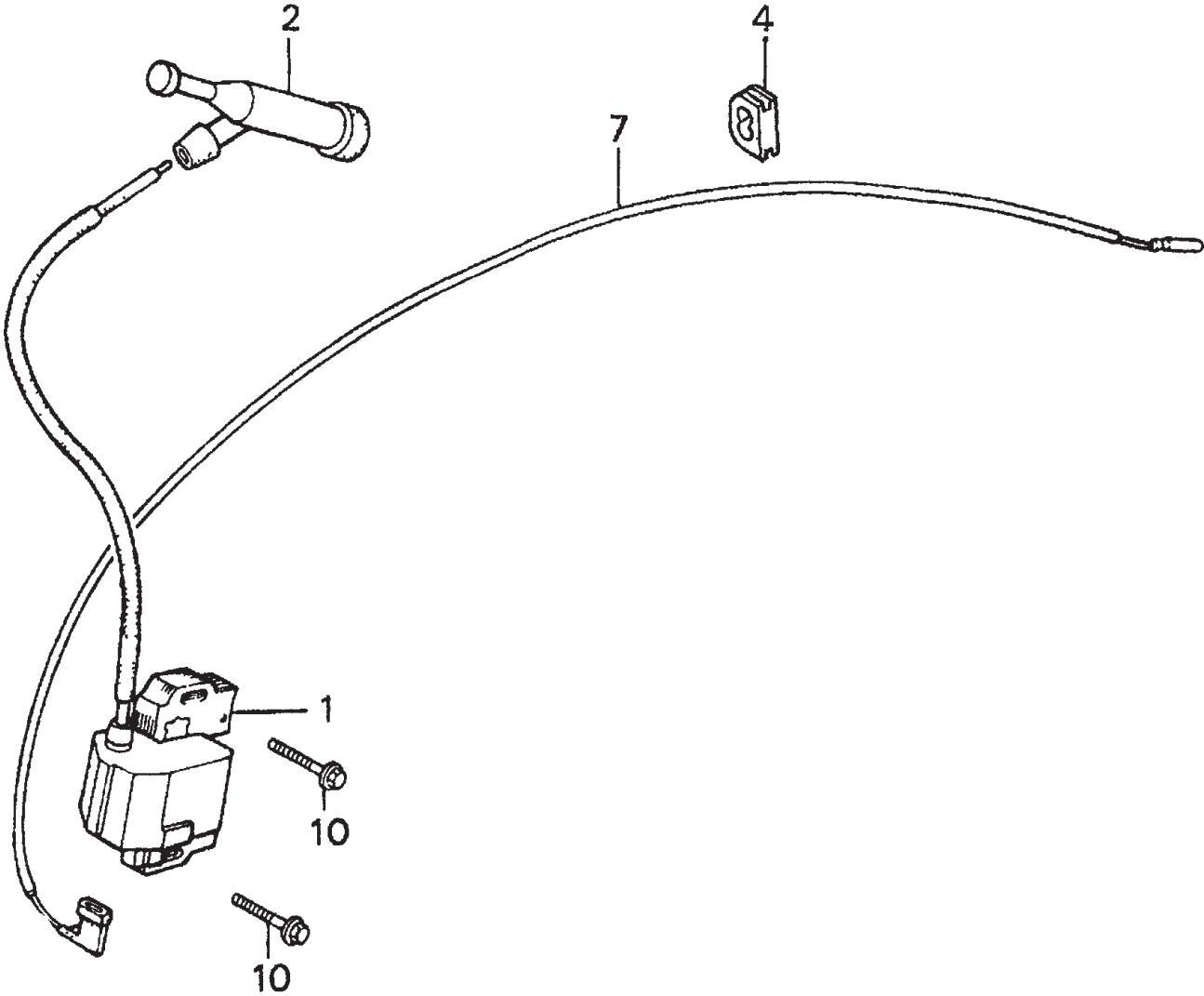

HONDA GX-340K1QAP2 ENGINE — IGNITION COIL ASSY.

IGNITION COIL ASSY.

<u>NO.</u>	<u>PART NO.</u>	<u>PART NAME</u>	<u>QTY.</u>	<u>REMARKS</u>
1	30500ZE2023	COIL ASSEMBLY, IGNITION	1	
2	30700ZE1013	CAP ASSEMBLY, NOISE SUPPRESSOR	1	
4	31512ZE2000	GROMMET, WIRE	1	
7	36101ZE2701	WIRE, STOP SWITCH 430MM	1	
10	90015883000	BOLT, FLANGE 6X28	2	

HONDA GX-340K1QAP2 ENGINE — MUFFLER ASSY.

MUFFLER ASSY.

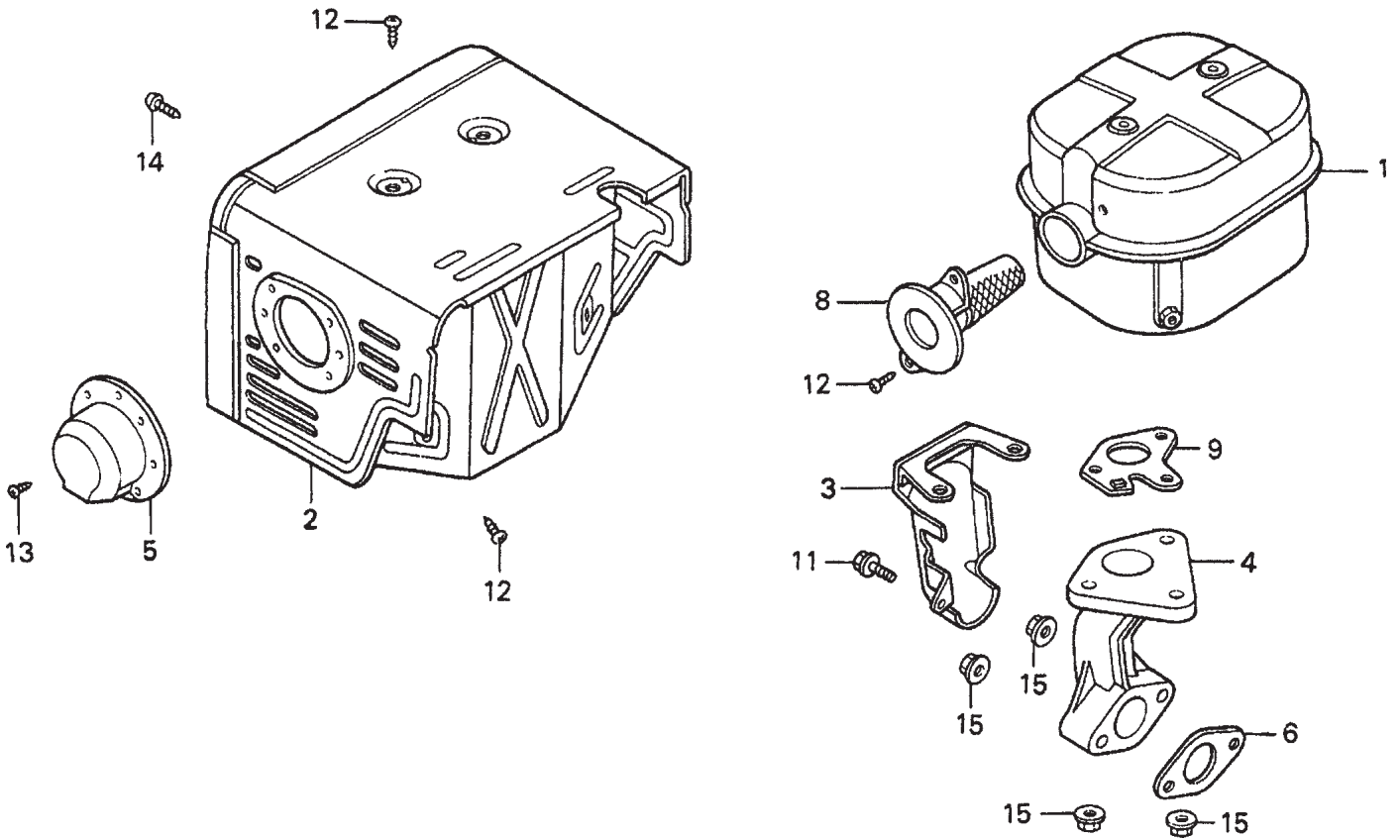

HONDA GX-340K1QAP2 ENGINE — MUFFLER ASSY.

MUFFLER ASSY.

<u>NO.</u>	<u>PART NO.</u>	<u>PART NAME</u>	<u>QTY.</u>	<u>REMARKS</u>
1	18310ZE3W00	MUFFLER	1	
2	18320ZE3W01	PROTECTOR, MUFFLER	1	
3	18323ZE3W40	PROTECTOR, EXHAUST PIPE	1	
4	18330ZE2W00	PIPE, EXHAUST	1	
5	18331ZE3810	CAP, MUFFLER	1	
6	18333ZF6W01	GASKET, EXHAUST PIPE	1	
8	18355ZE3010	ARRESTER, SPARK	1	
9	18381ZE2W10	GASKET, MUFFLER (ARRESTER)	1	
11	90013883000	BOLT, FLANGE 6X12 (CT200)	1	
12	90050ZE1000	SCREW, TAPPING 5X8	6	
13	90055ZE1000	SCREW, TAPPING 4X6	3	
14	93500060060B	SCREW, PAN 6X6	1	
15	9405008000	NUT, FLANGE 8MM	5	

HONDA GX-340K1QAP2 ENGINE — PISTON ASSY.

PISTON ASSY.

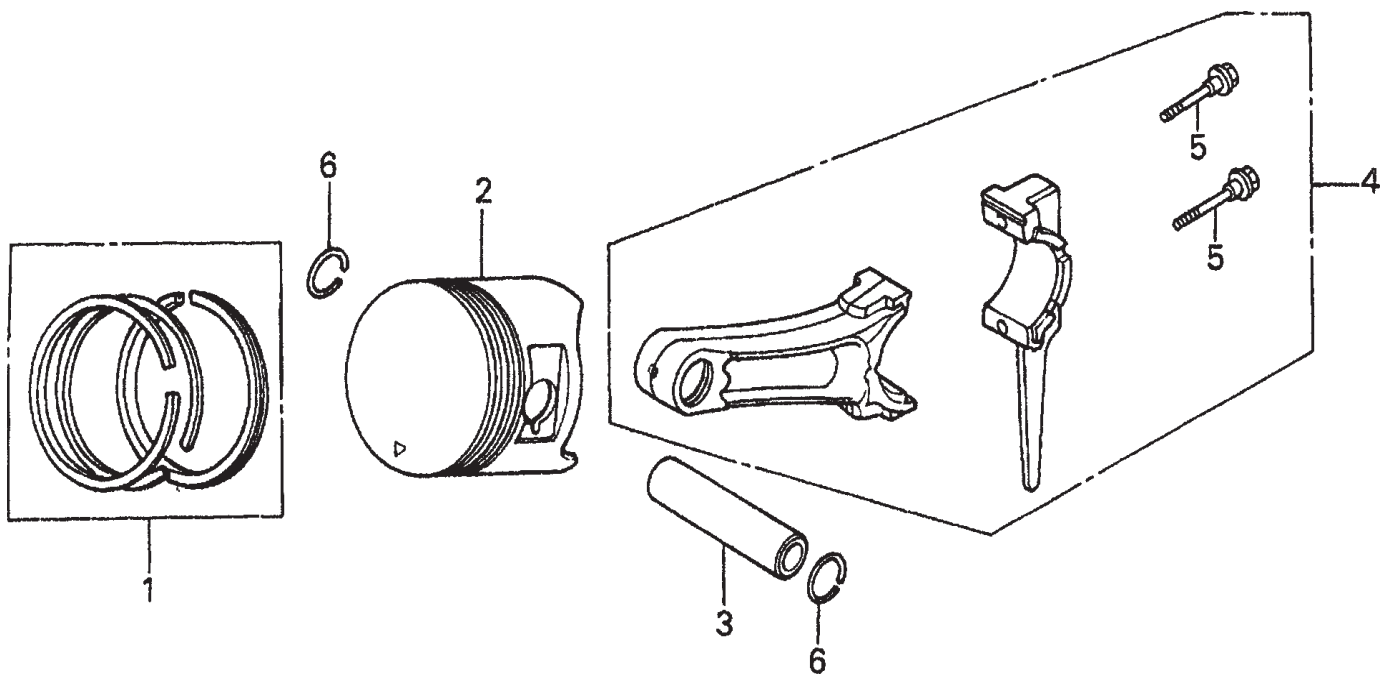

HONDA GX-340K1QAP2 ENGINE — PISTON ASSY.

PISTON ASSY.

<u>NO.</u>	<u>PART NO.</u>	<u>PART NAME</u>	<u>QTY.</u>	<u>REMARKS</u>
1	13010ZE3003	RING SET, PISTON (STANDARD)	1	
1	13011ZE3003	RING SET, PISTON (OS 0.25)	1	
1	13012ZE3003	RING SET, PISTON (OS 0.50)	1	
1	13013ZE3003	RING SET, PISTON (0.75)	1	
2	13101ZE3W00	PISTON STANDARD	1	
2	13102ZE3W00	PISTON (OS 0.25)	1	
2	13103ZE3W00	PISTON (OS 0.50)	1	
2	13104ZE3W00	PISTON (0.75)	1	
3	13111ZF6000	PIN, PISTON	1	
4	13200ZE3010	ROD ASSEMBLY, CONNECTING (STD.)	1	
4	13200ZE3315	ROD ASSEMBLY, CONNECTING (US 0.25)	1	
5	90001ZE8000	BOLT, CONNECTING ROD	2	
6	90601ZE3000	CLIP, PISTON PIN 20MM	2	

HONDA GX-340K1QAP2 ENGINE — RECOIL STARTER ASSY.

RECOIL STARTER ASSY.

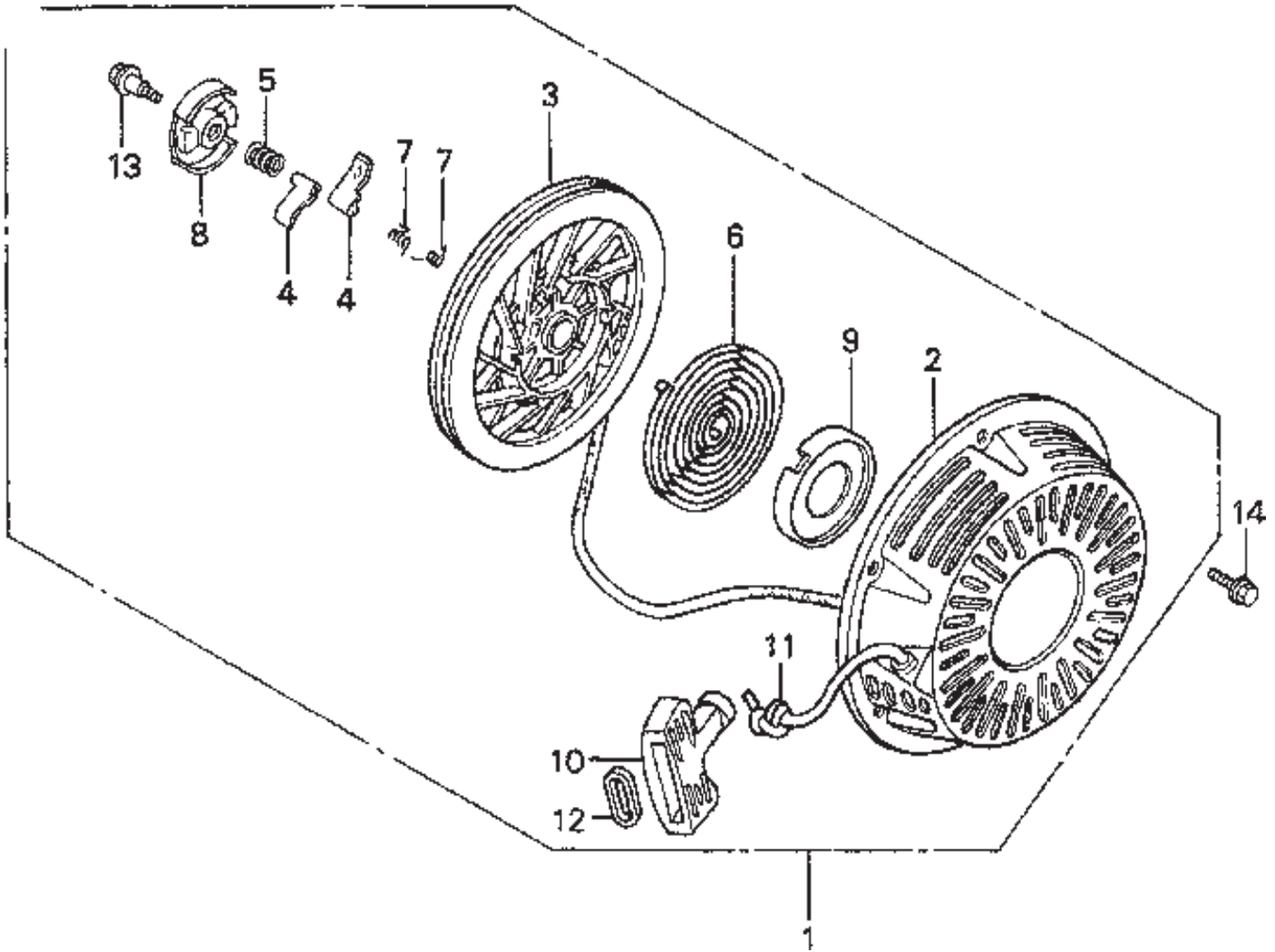

HONDA GX-340K1QAP2 ENGINE — RECOIL STARTER ASSY.

RECOIL STARTER ASSY.

<u>NO.</u>	<u>PART NO.</u>	<u>PART NAME</u>	<u>QTY.</u>	<u>REMARKS</u>
1	28400ZE3W01ZB	STARTER ASSY., RECOIL "NH1"	1	BLACK
2	28410ZE3W01ZB	CASE, RECOIL STARTER "NH1"	1	BLACK
3	28421ZE3W01	PULLEY, RECOIL STARTER	1	
4	28422ZE2W01	RATCHET, STARTER	2	
5	28441ZE2W01	SPRING, FRICTION	1	
6	28442ZE2W01	SPRING, STARTER RETURN	1	
7	28443ZE2W01	SPRING, RATCHET	2	
8	28444ZE2W01	RETAINER, SPRING	1	
9	28445ZE2W01	HOLDER, SPRING	1	
10	28461ZE2W02	GRIP, STARTER	1	
11	28462ZE3W01	ROPE, RECOIL STARTER	1	
12	28469ZE2W01	GRIP, REINFORCEMENT	1	
13	90004ZE2W01	SCREW, CENTER	1	
14	957010600800	BOLT, FLANGE 6X8	3	

HONDA GX-340K1QAP2 ENGINE — ENGINE LABELS ASSY.

ENGINE LABELS ASSY.

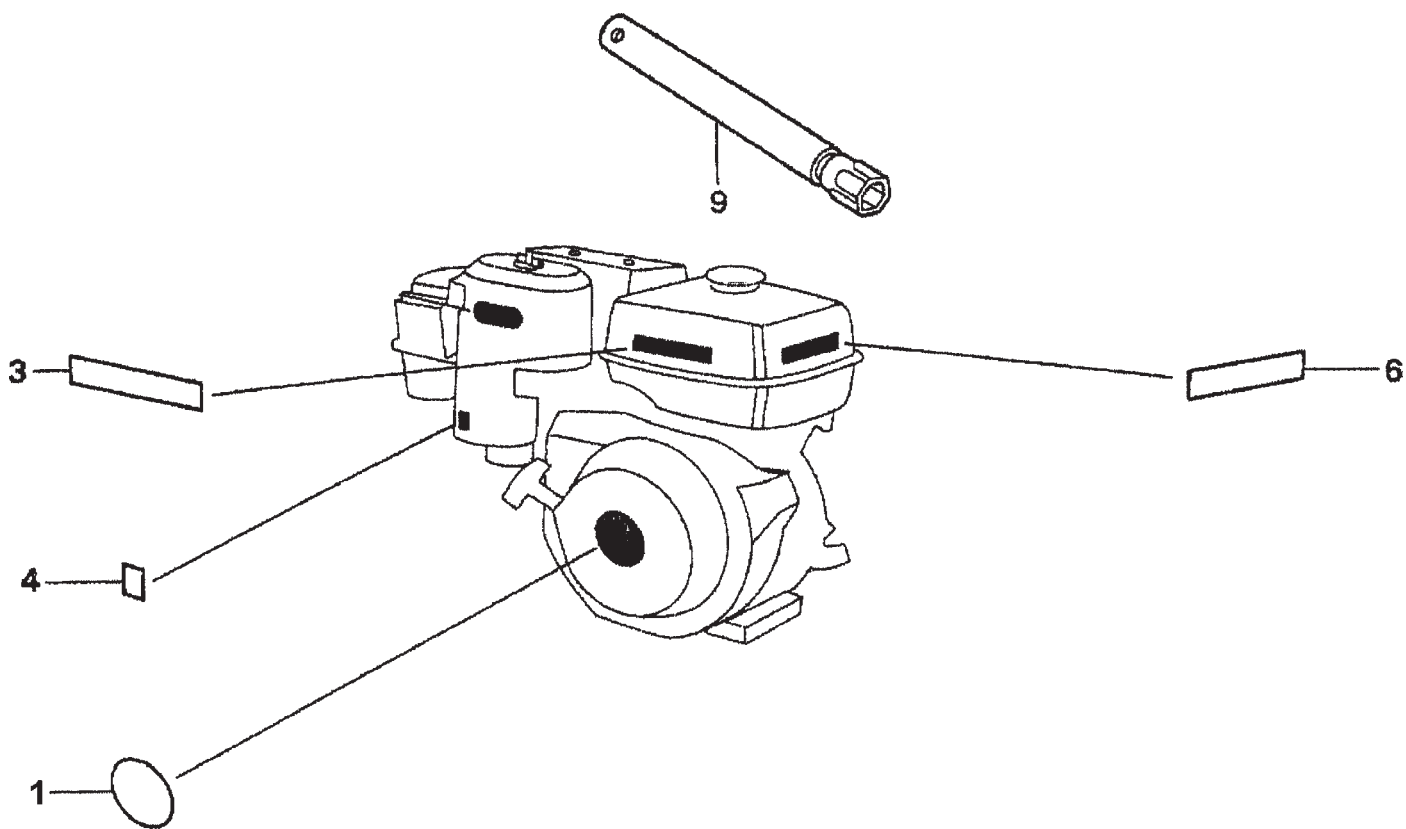

HONDA GX-340K1QAP2 ENGINE — ENGINE LABELS ASSY.

ENGINE LABELS ASSY.

<u>NO.</u>	<u>PART NO.</u>	<u>PART NAME</u>	<u>QTY.</u>	<u>REMARKS</u>
1	87521ZE3W01	EMBLEM	1	
3	87522ZH9000	LABEL, CAUTION	1	
4	87528ZE2810	MARK, CHOKE (EXTERNAL)	1	
6	87532ZH8810	MARK, OIL ALERT (E)	1	
9	89218ZE1000	WRENCH, SPARK PLUG	1	

PAYMENT TERMS

Terms of payment for parts are net 10 days.

FREIGHT POLICY

All parts orders will be shipped collect or prepaid with the charges added to the invoice. All shipments are F.O.B. point of origin. Multiquip's responsibility ceases when a signed manifest has been obtained from the carrier, and any claim for shortage or damage must be settled between the consignee and the carrier.

MINIMUM ORDER

The minimum charge for orders from Multiquip is \$15.00 net. Customers will be asked for instructions regarding handling of orders not meeting this requirement.

RETURNED GOODS POLICY

Return shipments will be accepted and credit will be allowed, subject to the following provisions:

1. A Returned Material Authorization must be approved by Multiquip prior to shipment.
2. To obtain a Return Material Authorization, a list must be provided to Multiquip Parts Sales that defines item numbers, quantities, and descriptions of the items to be returned.
 - a. The parts numbers and descriptions must match the current parts price list.
 - b. The list must be typed or computer generated.
 - c. The list must state the reason(s) for the return.
 - d. The list must reference the sales order(s) or invoice(s) under which the items were originally purchased.
 - e. The list must include the name and phone number of the person requesting the RMA.
3. A copy of the Return Material Authorization must accompany the return shipment.

4. Freight is at the sender's expense. All parts must be returned freight prepaid to Multiquip's designated receiving point.
5. Parts must be in new and resalable condition, in the original Multiquip package (if any), and with Multiquip part numbers clearly marked.
6. The following items are not returnable:
 - a. Obsolete parts. (If an item is listed in the parts price book as being replaced by another item, it is obsolete.)
 - b. Any parts with a limited shelf life (such as gaskets, seals, "O" rings, and other rubber parts) that were purchased more than six months prior to the return date.
 - c. Any line item with an extended dealer net price of less than \$5.00.
 - d. Special order items.
 - e. Electrical components.
 - f. Paint, chemicals, and lubricants.
 - g. Decals and paper products.
 - h. Items purchased in kits.
7. The sender will be notified of any material received that is not acceptable.
8. Such material will be held for 5 working days from notification, pending instructions. If a reply is not received within 5 days, the material will be returned to the sender at his expense.
9. Credit on returned parts will be issued at dealer net price at time of the original purchase, less a 15% restocking charge.
10. In cases where an item is accepted for which the original purchase document can not be determined, the price will be based on the list price that was effective twelve months prior to the RMA date.
11. Credit issued will be applied to future purchases only.

PRICING AND REBATES

Prices are subject to change without prior notice. Price changes are effective on a specific date and all orders received on or after that date will be billed at the revised price. Rebates for price declines and added charges for price increases will not be made for stock on hand at the time of any price change.

Multiquip reserves the right to quote and sell direct to Government agencies, and to Original Equipment Manufacturer accounts who use our products as integral parts of their own products.

SPECIAL EXPEDITING SERVICE

A \$20.00 to \$50.00 surcharge will be added to the invoice for special handling including bus shipments, insured parcel post or in cases where Multiquip must personally deliver the parts to the carrier.

LIMITATIONS OF SELLER'S LIABILITY

Multiquip shall not be liable here under for damages in excess of the purchase price of the item with respect to which damages are claimed, and in no event shall Multiquip be liable for loss of profit or good will or for any other special, consequential or incidental damages.

LIMITATION OF WARRANTIES

No warranties, express or implied, are made in connection with the sale of parts or trade accessories nor as to any engine not manufactured by Multiquip. Such warranties made in connection with the sale of new, complete units are made exclusively by a statement of warranty packaged with such units, and Multiquip neither assumes nor authorizes any person to assume for it any other obligation or liability whatever in connection with the sale of its products. A part from such written statement of warranty, there are no warranties, express, implied or statutory, which extend beyond the description of the products on the face hereof.

PARTS AND OPERATION MANUAL

HERE'S HOW TO GET HELP

*PLEASE HAVE THE MODEL AND SERIAL NUMBER
ON-HAND WHEN CALLING*

PARTS DEPARTMENT

800-427-1244 or 310-537-3700

FAX: 800-672-7877 or 310-637-3284

SERVICE DEPARTMENT/TECHNICAL ASSISTANCE

800-478-1244 or 310-537-3700

FAX: 310- 537-4259

WARRANTY DEPARTMENT

888-661-4279, or 310-661-4279

FAX: 310- 537-1173

MAIN

800-421-1244 or 310-537-3700

FAX: 310-537-3927

STOW
A DIVISION OF MULTIQUIP INC.

SCT SERIES CONSTRUCTION EQUIPMENT

A DIVISION OF MULTIQUIP INC.

POST OFFICE BOX 6254

CARSON, CA 90749

310-537-3700 • 888-252-SCT SERIES[888-252-7869]

FAX: 310-537-1986 • FAX: 800-556-1986

E-MAIL: stow@multiquip.com • WWW: stowmfg.com

PARTS DEPARTMENT:

800-427-1244

FAX: 800-672-7877

SERVICE DEPARTMENT/TECHNICAL ASSISTANCE:

800-478-1244

FAX: 310-631-5032