

INSTRUCTION MANUAL

Battery powered below the hook vacuum lifting device
for sandwich roof- and wall panels



Read this manual carefully before operating this lifter.

Index

A 1	Introduction.....	3
A 2	EC-declaration of conformity	5
A 3	Definitions	6
B 1	Operators declaration	1
B 2	Operating limits.....	2
B 3	Operation	3
B 4	Storage.....	7
B 5	Battery	8
B 6	Transport- and manipulation possibilities.....	9
B 7	Options	21
B 8	Safety precautions.....	27
C 1	Expert declaration	1
C 2	Technical data.....	2
C 3	Checking and maintenance	3
C 4	Inspection & maintenance report	6
C 5	Fitting sealing profile in suction pad	8
C 6	Mal functioning and repair	9
C 7	Electric diagram.....	10
C 8	Vacuum diagram.....	19
C 9	Digital vacuum switch.....	20
C 10	Spare parts.....	21
C 11	Maintenance record	33
C 12	Erradata	35

A 1 Introduction

Dear reader,

This manual is subdivided in the following sections:

A General section

This section is intended for anyone who uses this manual.

B Operators section

This section is intended for anyone who utilizes and operates this device.

C Technical section

This section is intended for the specialist staff who take care for maintenance and repair of this device.

Depending your function you need to read carefully the belonging section.

To operate this device safely it is important that you strictly follow the instructions.

If you are in doubt, or face problems when use, maintenance or repair, please contact your authorized VIAVAC dealer. They will do their utmost to serve you in an adequate and quick way.

In the text of this manual the following symbols are used.



TIP:

Gives suggestions and advice to perform certain tasks in an easier and more effective way.



TAKE CARE

a remark with additional information, draws your attention for possible problems.



WARNING

If these instructions are not carefully being executed, this can result in (serious) injuries or even death.

These symbols indicate important information.

You need to be convinced that anyone who utilises this device has understood this information well.

This manual should be made available to anyone who operates, checks or repairs this device.

To have the manual available it should be stored at the designated spot together with the device.

REMARK

In this manual there are 2 versions of the VIAVAC-CB being described, namely:

- CB 4 : Manual operated "Suction and release" by ball valve on the main unit.
CB 4.1 : Remote control operation "Suction and release" is possible because of electric valve on the main unit .
Optional there are 2 type of remote control can be installed.
1. Remote control box, connected with electric cable to the main unit.
2. Radio Remote control, by transmitter and a built in receiver in the main unit.

These versions differ only concerning operation suction and release..

Where applicable, it will be indicated which version it concerns by marking (CB 4) or (CB 4.1).

What is your version is indicated on the identification plate which is attached to the device.

A 2 EC-declaration of conformity

Complies to enclosure II A from directive 2006/42/EG



The manufacturer:

VIAVAC vacuum lifting BV
 Bedrijfsweg 6
 3411 NV Lopik
 The Netherlands

Hereby declares that:

Machine : Vacuum lifter
 Type : **VIAVAC CB**
 Machine nr. :

Complies with the following standards and directives:

- Machine directive 2006/42/EG with alterations
- Low voltage directive 2014/35/EU
- EMC directive 2014/30/EU
- American standard ASME B30.20-2010
- American standard ASME BTH1-2011 design category "A", Service Class "0"
- Australian Standard AS 4991-2004

The following European standards have been applied:

Safety of machinery	Basic concepts	EN-ISO 12100-1
Safety of machinery	Basic design principles	EN-ISO 12100-2
Safety of machinery	Principles of risk assessment	EN-ISO 14121
Safety of machinery	Audible and visual warning signals	EN 981+A1
Safety of machinery	Electrical equipment for machines	EN 60204-1:2001
Crane safety	Non-fixed load lifting attachments	EN 13155+A2

Date:

Signature

Arie de Groot

Managing director

A 3 Definitions

Operator	Person or persons who operate and utilizes the vacuum lifter.
Lifting device	Lifting crane, overhead crane, forklift truck or any other, well or not into a machine integrated lifting arrangement, where the vacuum lifter is suspended on and lifting tasks are being executed.
Load	The object being transported and/or handled by the vacuum lifter.
Working load Limit	The maximum weight of the load which can be transported safely with the vacuum lifter
Suction	By actuating a valve, sucking the load fixed to the suction pad.
Aerating	By actuating a valve, releasing the load by enabling air flowing to the suction pad
Maintenance expert	Expert who is responsible for inspection, maintenance and repair of the vacuum lifting device.
Load ratio	Ratio between the maximum calculated load which can be lifted with the device and the safe working load which is indicated on the device.
Testing ratio	Ratio between the load, used for the static test of the vacuum lifter and the safe working load indicated on the device
Static test	Test where the vacuum lifter should withstand a static force equivalent to 2x working load limit without permanent deformation and after removal of the force, there shall be no visible defects.
Holding time Test	With the suction pad in vertical position, a (non porous) load corresponding the working load limit is lifted. After this, the main switch is switched off so the vacuum pump will not run anymore. The vacuum lifter should be able to hold the load for a prescribed time.

B 1 Operators declaration

The undersigned hereby declares that before operating this vacuum lifter, he has read and understood the operators section of this instruction manual and will follow the instructions and guidelines.

Control of the management on compliance is required.

<u>DATE</u>	<u>NAME</u>	<u>SIGNATURE</u>
.....
.....
.....
.....
.....
.....
.....
.....
.....

B 2 Operating limits

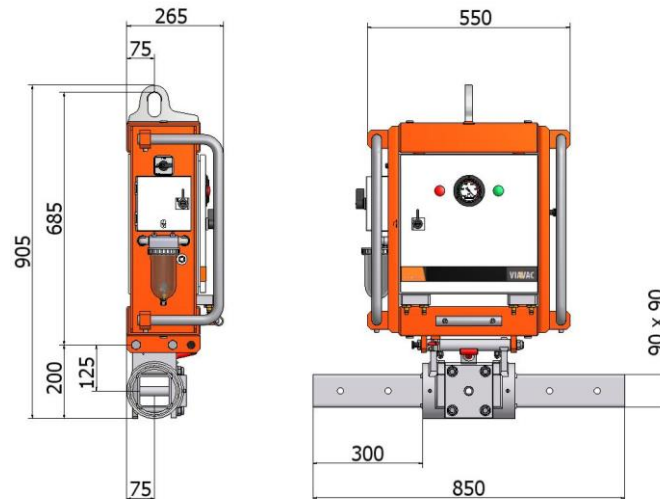

Lifting capacity	max. 800kg, but actual S.W.L depends of the total lifting capacity of the active suction pads required for the job specific configuration.
Own weight	c.a. 100kg
Load	Steel faced composite roof and wall panels. It may also be possible to lift other non porous materials but it is recommended that test lifts are performed. The suction area may be flat as slightly structured. The suction pad seal can compensate (when not too rough) unevenness's up to 5mm.
Capabilities	- 90° tilting from horizontal to vertical with locking facility in vertical position.
Operation elevation	Max. 1.200 m. above sea level (if higher, settings vacuum switch needs to be adapted).
Operating Temperatures	0°C to +40°C -10°C to 0°C with special precautions.
Service life	At least 20.000 cycles 10 years, when properly maintained and used as intended.
Outside use	This lifter can also be used outside, however not in area with explosive danger.
Rain and snow	This lifter may also be used in rain and snow conditions, however there should be taken care that excessive water, snow and ice is removed from the suction area. Water or ice strongly reduces the necessary friction between suction pad and load. This friction is essential to lift the load in vertical position of the suction pad.
Wind	Do not use this lifter at wind speeds above 11 meter/sec. The maximum wind speed will reduce as panels get longer. See wind speed tables per machine configuration.
Non rigid plates	This lifter is not suitable to lift non rigid plates. (plate can peel of from the suction pad causing to release the load.
	Extra regulations according CE standard EN 13155 When this lifter is being used for the erection, renovation or demolishing of buildings or other building constructions, the use of a falling safety device is required.

B 3 Operation

CB 4 Vacuum unit with handle "suction / release"

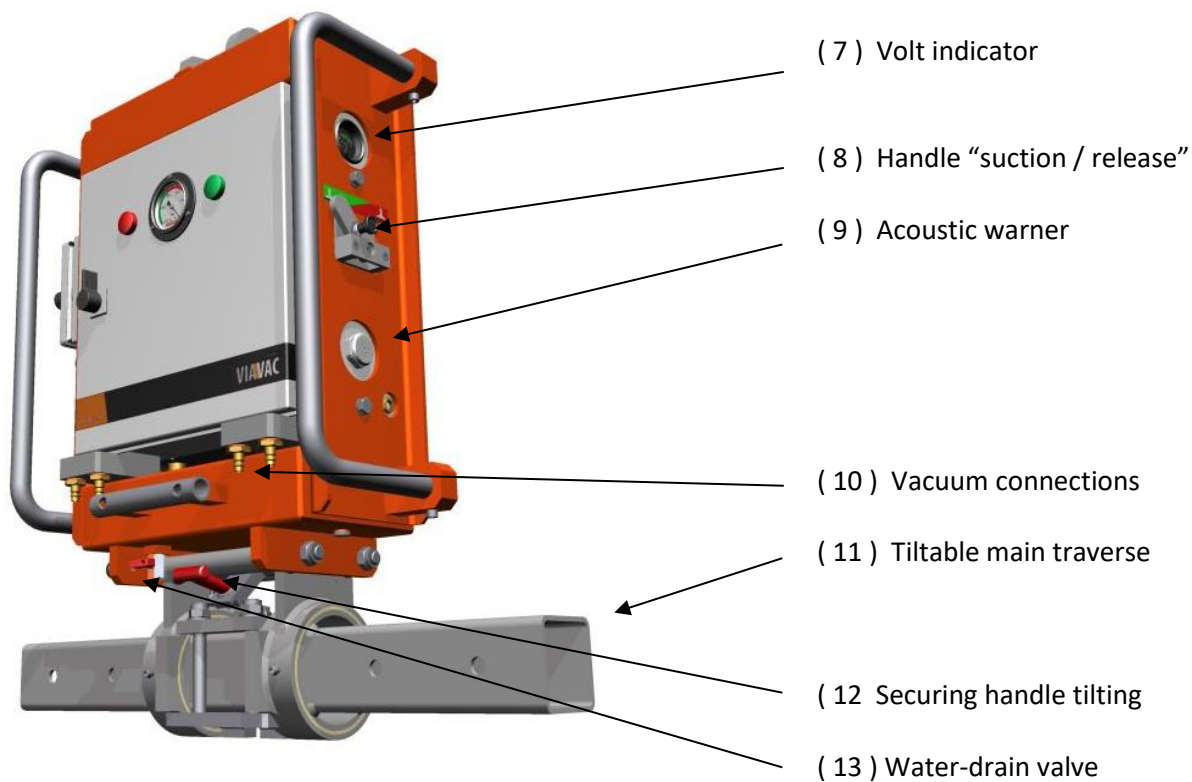
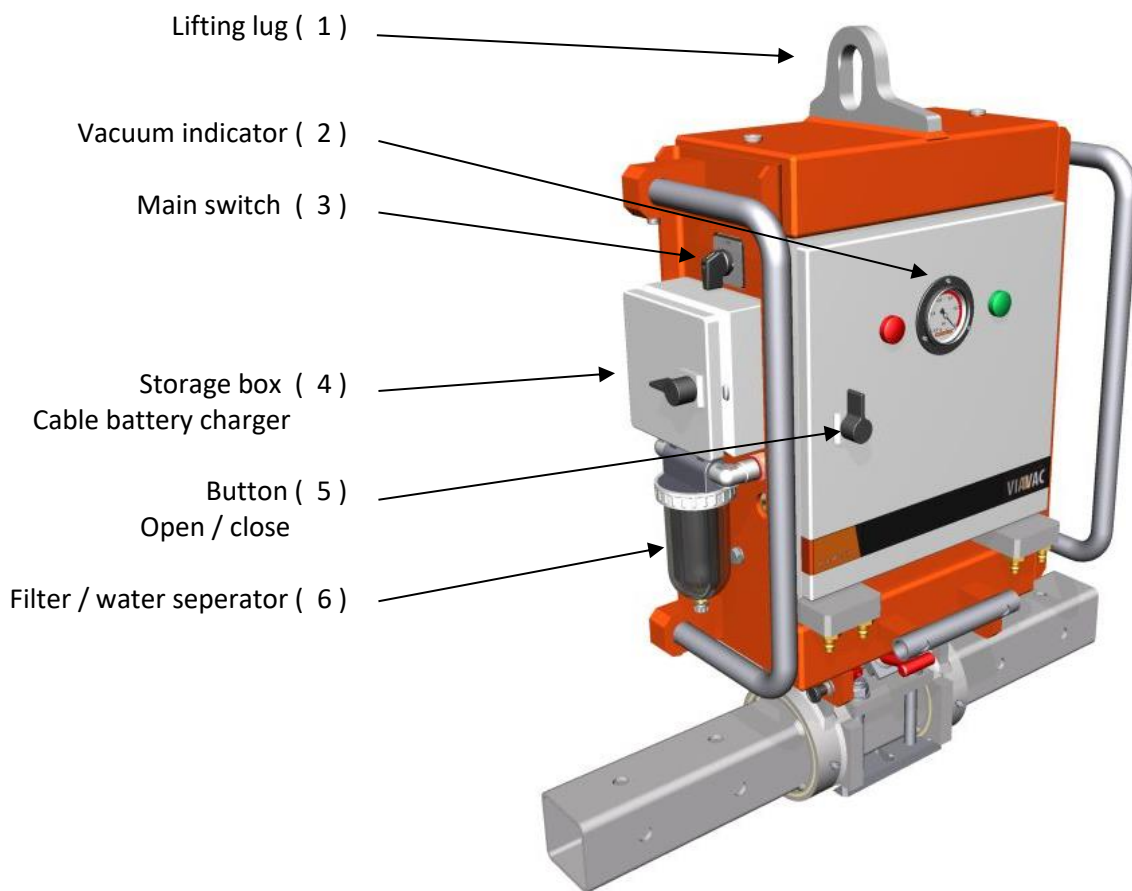

CB 4.1 Vacuum unit prepared for optional remote control

The CB 4.1. is identical to the CB4 except for the following:

- To permit remote control, the hand actuated valve is replaced by electro magnetic 3/2 valves.
- 3 buttons on the front door for suction (1 green) and release (2 red buttons).
- Connector to fit additional remote control on cable.



Cable remote control

This can easily be installed by simply connecting the connector at the side of the device.

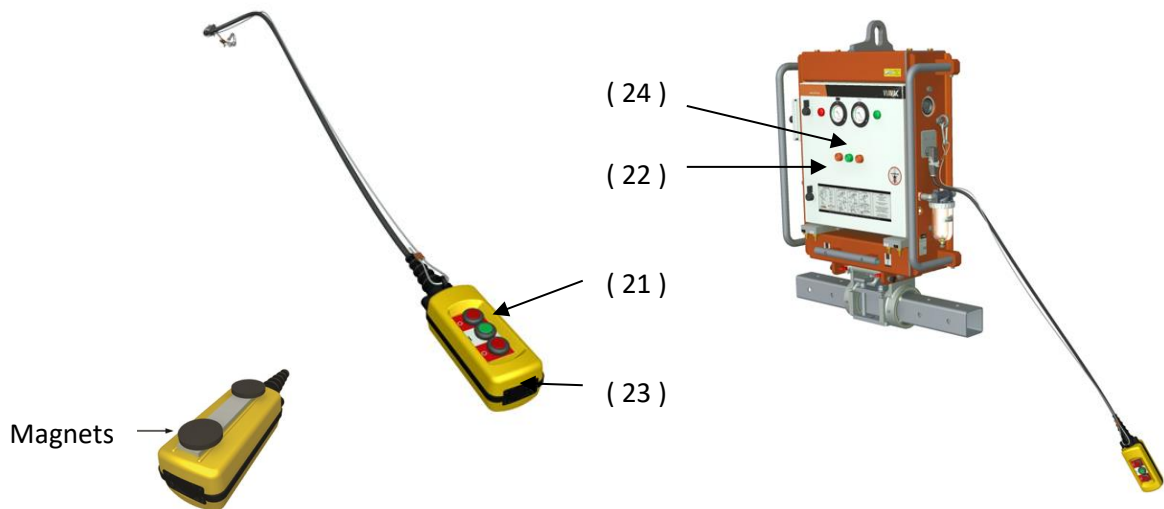

Radio Remote Control

For this, a receiver box has is installed into the switchbox. Suction and release can be activated on the transmitter.

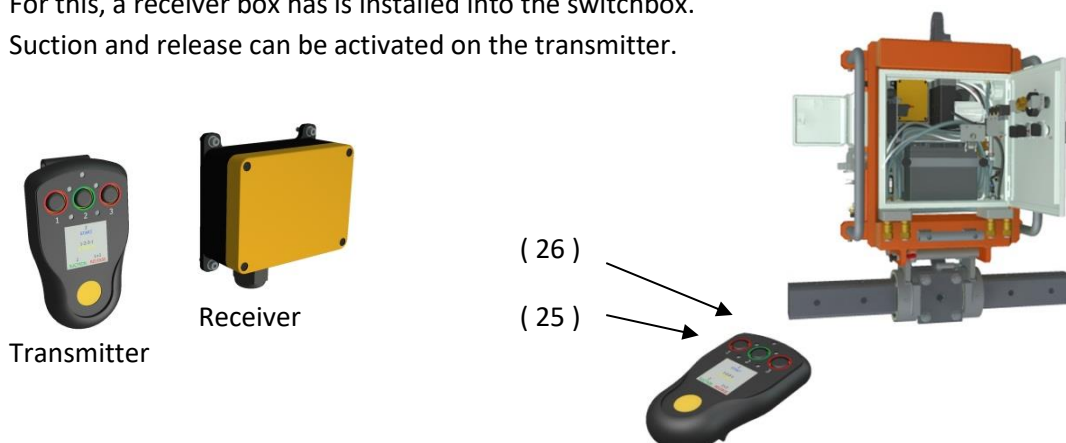

Operation procedure CB4

1. Suspend device at the crane hook by the lifting eye (1).
2. Before every lift, check the condition of the rubber sealing profile of the suction pad, there may be no tears or damage to it.
3. Before every lift, check the black rubber back plate at the backside of the suction cups; these must be clean and free from oil, grease or water drops.
4. Before every lift check that all locking pins are in place and secured.
5. Ensure that the control lever (8) "suction & aerating" is set to the back (read area)
Start up the device by setting the main switch (3) on 1.
-Now you will hear the vacuum pump running, it will stop 10 seconds after a vacuum level of -0.65 bar has been built up in the vacuum buffer tank.
- The alarm is audible and the red lamp will light up as long as the vacuum level is still below -0.6-bar, above that the alarm will stop and the green lamp will light up instead of the red one.
6. Check on the volt meter (7) whether the battery has been sufficiently charged; the pointer must remain between the 11 and 13 volt while the vacuum pump is running.
7. Use the control lever (12) to set the suction pad in the right position.
- Lever up: enables to rotate the main traverse with 90°.
8. Put the device with the suction pad on the load, ensure that the suction surface is dry and clean.
9. Set the control lever (8) at suction (green area).
10. Check on the vacuum meter (2) whether the required vacuum level of >-0.60 bar has been built up (pointer in the green area).
11. If used on the building site in the EU, lift the load a little and attach the fall safety straps as indicated.
12. The load can now be lifted further and, just before the load is set on its place, the falling safety strap should be removed, if applicable.
13. When the load has been put on its place and is secured, set the control lever (8) at aerating (red area).
14. The suction pad will release and then a new load can be taken up by putting the suction pad on it and putting the control lever (8) at "suction".
15. After the last element has been placed, disconnect the device by setting the main switch (3) on 0.

Operation procedure CB4.1 with cable remote control

This is identical to CB4 except for at the following points:

5. Ensure that the device is set to "release" bij pressing simoultaneously the 2 red buttons (21 or 22).
9. Set the device to "suction"by pressing the green button (23 or 24).
13. When the load has been put on its place and is secured, set the device on "release" by simoultaneously pressing the 2 red buttons (21 or 22).
14. A new load can be picked up "by pressing the green button (23 or 24).

Operation procedure CB4.1 with radio remote control

This is identical to CB4 except for at the following points:

For safety reasons, a code on the transmitter has to be pressed first before it is possible to activate "suction & release".

5. Ensure that the device is set to "release" bij pressing simoultaneously the 2 red buttons (21 or 25).
9. Set the device to "suction"by pressing the green button (23 or 26).
13. When the load has been put on its place and is secured, set the device on "release" by simoultaneously pressing the 2 red buttons (21 or 22).
14. A new load can be picked up "by pressing the green button (23 or 24).

Before any lift, the user must check the following:

- I. Check the rubber sealing profile of the suction pad for damage and cracks, replace if necessary.
- II Check rubber back plate of the suction pad to verify whether it is clean and free from grease, oil or water drops and, if necessary, to clean it up.
- III Whether the battery is sufficiently charged; The volt meter (8) must indicate between 11 and 13 Volt.
- IV Functioning of the acoustic alarm (11) at a vacuum level below -0.60m bar.
This can be checked by briefly putting the control lever (8) in the position "suction" (green area) before the suction pad is placed on the load.



Remove excessive water, snow and ice at the area where suction pads are placed on load. This is essential to have sufficient friction needed for lifting in vertical or inclined position.



If the load has a protective film, it must first be removed before the suction pad is placed on the load.

During every lift the operator must constantly monitor the following:

- a. Vacuum meter, during lifting the pointer must constantly remain in the green area.
- b. Acoustic alarm signal; during the lift it may not be audible.



If the vacuum meter is in the red area and/or the acoustic alarm signal sounds, do not lift!
If the vacuum meter is in the red area and/or the acoustic alarm signal sounds, a lifted load must be put down as quickly as possible.

If the vacuum pump for some reason fails, from the moment the vacuum level decreases below the required level of > -0.60 , the load will be held for a minimum of 5 minutes.

To work safely with the device, it is therefore necessary that:

- The operator must have good hearing and is not using hearing protection.
- During the lifting the operator must be within hearing and visibility distance of the device.
- The ambient sound does not amount to more than 70db.
- The operator of the device is constantly in contact with the operator of the lifting machine and agreements have been made about a clear communication.

Protective precautions at operation temperatures between the -10°C and 0°C.

- To prevent clogging of the filters, it has to be ensured that all the humidity has been removed from the device. This is achieved by letting the vacuum pump run approx. 15 minutes with the control level (9) in the position "suction" in a dry and heated compartment.
- To be assured of sufficient battery capacity, store the device at a temperature of 15°C or higher at night.
- For sufficient friction between suction pad and the load, it must be ensured for every lift that both the suction pad and the suction surface of the load, all water, snow and ice is removed.

**Adjustments needed when working at altitudes above 1200mtr from seal level.**

The reduced atmospheric pressure at high altitudes affects the vacuum switch which controls switching on and off of the vacuum pump and the alarm.

Depending on the altitude the settings of the switch needs needs to be adapted.

Procedure and required settings can be obtained from VIAVAC when needed.



The vacuum pump can run approx. 120 minutes constantly with a fully charged battery.

To ensure that it is possible to work a whole day with a battery load, the user must also keep an eye on the vacuum condition of the system during the operation:

This is done by checking that the vacuum pump stops 10 seconds after a vacuum level of 0.65 bar has been reached. Then it must take at least 30 seconds before it starts pumping again.

If the pump starts up more frequently, this indicates a leak and this causes the battery to discharge faster than expected and one cannot operate for a whole day.

Therefore it is advisable to first rectify this, before the work is continued.

**Reduced lifting capacity at higher altitudes**

Lifting capacity of the suction pads are set at 500m altitude at an atmospheric pressure of 950mbar. With increase of height, atmospheric pressure reduces and so does lifting capacity.

This reduction has to be taken into account when lifting at altitudes above 500meter from sea level.

<u>Altitude (meter)</u>	<u>Atmospheric pressure (mbar)</u>	<u>Lifting capacity</u>
0 ... 500	1050 ... 950	100%
501 ... 1000	949 ... 900	95%
1001 ... 1500	899 ... 850	90%
1501 ... 2000	849 ... 800	85%
2001 ... 2500	799 ... 750	80%
2501 ... 3000	749 ... 700	75%

Rated lifting capacity on suction pads is calculated with

- most unfavourable (-vertical) position of suction pad
- vacuum level of -600 mbar
- safety factor of 2

B 4 Storage

The device should be stored as follows:

Overnight at job site:

- keep the unit in a dry and above 0°C secure place.

Long time storage when out of use :

- In a dry place at temperatures between 15 and 25°C.
- Switched off, water drained, charged battery and suction pad shielded.

B 5 Battery

The battery can be charged by the battery charger, which is placed in the switchbox.

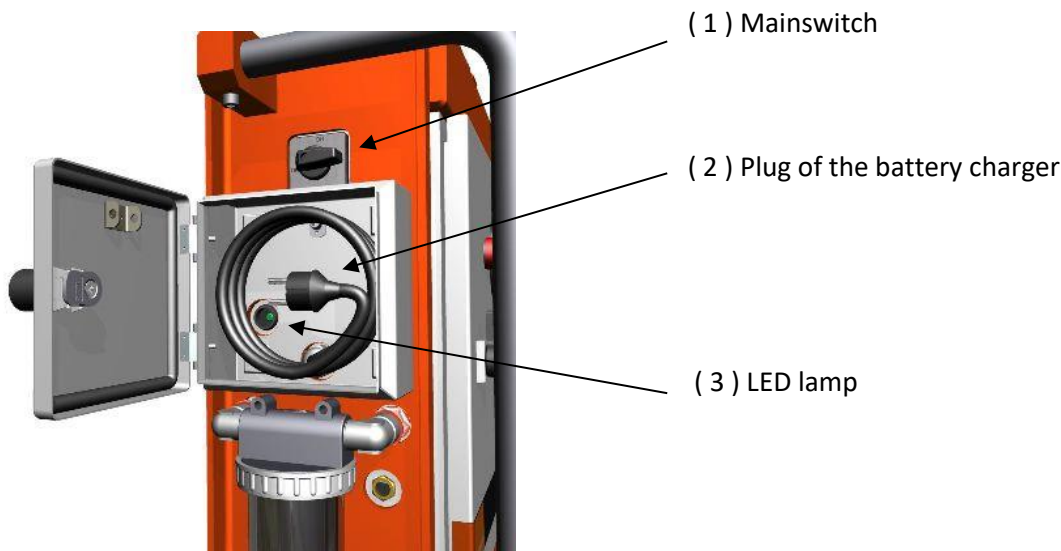

- Turn the main switch (1) off.
- Insert the plug of the charger (2) in the socket, the voltage of the mains should be between 110 ... 240V.
- The LED lamp changes during the load cycle from red (empty battery) to yellow (almost fully charged battery) to green (fully charged battery).

In approx. 6 hours loading time an empty battery (13) is again fully charged (green LED lamp is lighted). A full battery load is sufficient for placing a minimum of 120 elements (approx. 1 full day of operation).

When the green LED lamp is lighted, the battery charger will automatically switch to maintenance loading. The connector can therefore remain in the electric socket without any danger of overloading the battery.

In case of a charged battery the volt meter on the cabinet indicates between 12 ... 14 Volt, when the vacuum pump runs, it will fall back with approx. 1V.

If the meter falls back significantly to back with 2 or more Volt during additional pumping, this means that the battery is discharged.

In case of a discharged battery the vacuum pump will also run slower, due to which it will not achieve the set switch off vacuum level and the vacuum pump will run constantly.

If the voltage of the battery decreases below the 11V, the electronic vacuum switch will also turn off, because of this, the vacuum pump will run constantly, the red lamp will light up and the acoustic alarm signal will sound.

The battery will last approx. 3 to 5 years, because the capacity will decrease after time, we advise to renew the battery every 3 years as a precaution.



It improves the life time of the battery when it is stored in a charged state.

We recommend that, even if you don't need the device the next day, to charge immediately after use. Interim charging the battery has no negative impact on it's capacity (no memory effect).

B 6 Transport- and manipulation possibilities

TYPE SANDWICH ROOF PANELS

type RA (1)

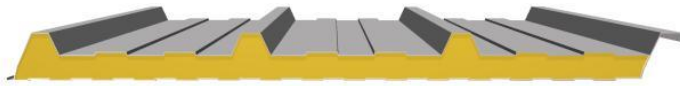

0,5 .. 0.7mm Steel / aluminium
PUR / EPS
0,4 .. 0.7mm Staal / aluminium

type RB (2)

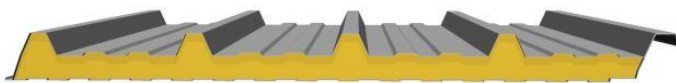

0,5 .. 0.7mm Steel / aluminium
PUR / EPS
Foil

type RB (3)

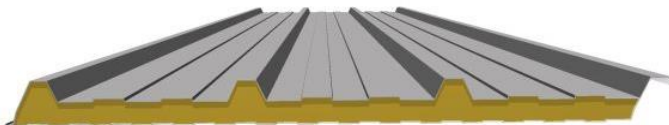

0,5 .. 0.7mm Steel / aluminium
Mineral wool
0,4 .. 0.7mm Steel / aluminium

type RB (4)



0,5 .. 0.7mm Steel / aluminium
PUR / EPS
0,4 .. 0.7mm Steel / aluminium

CB4 configuration type: R2600, R4400, R6200

For roof panels up to 16 meter length

Roof pitch 0 25°

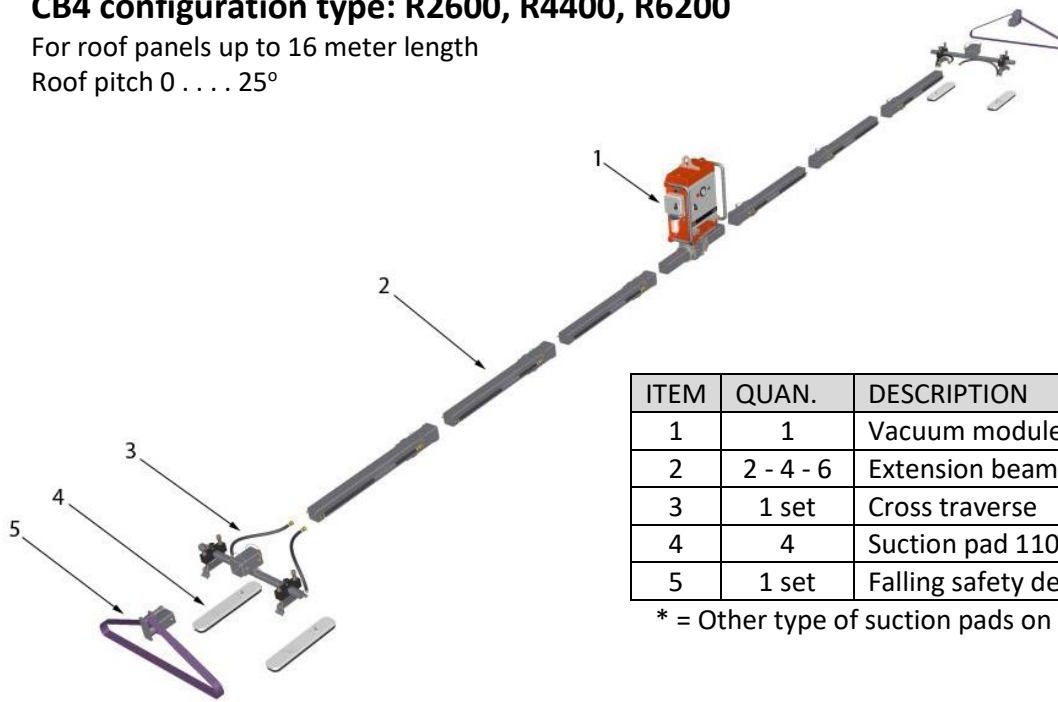

ITEM	QUAN.	DESCRIPTION	ART. NR
1	1	Vacuum module CB4	408500
2	2 - 4 - 6	Extension beam	408003
3	1 set	Cross traverse	408501
4	4	Suction pad 110x530, 75kg	402502*
5	1 set	Falling safety device FS4	408007

* = Other type of suction pads on request.

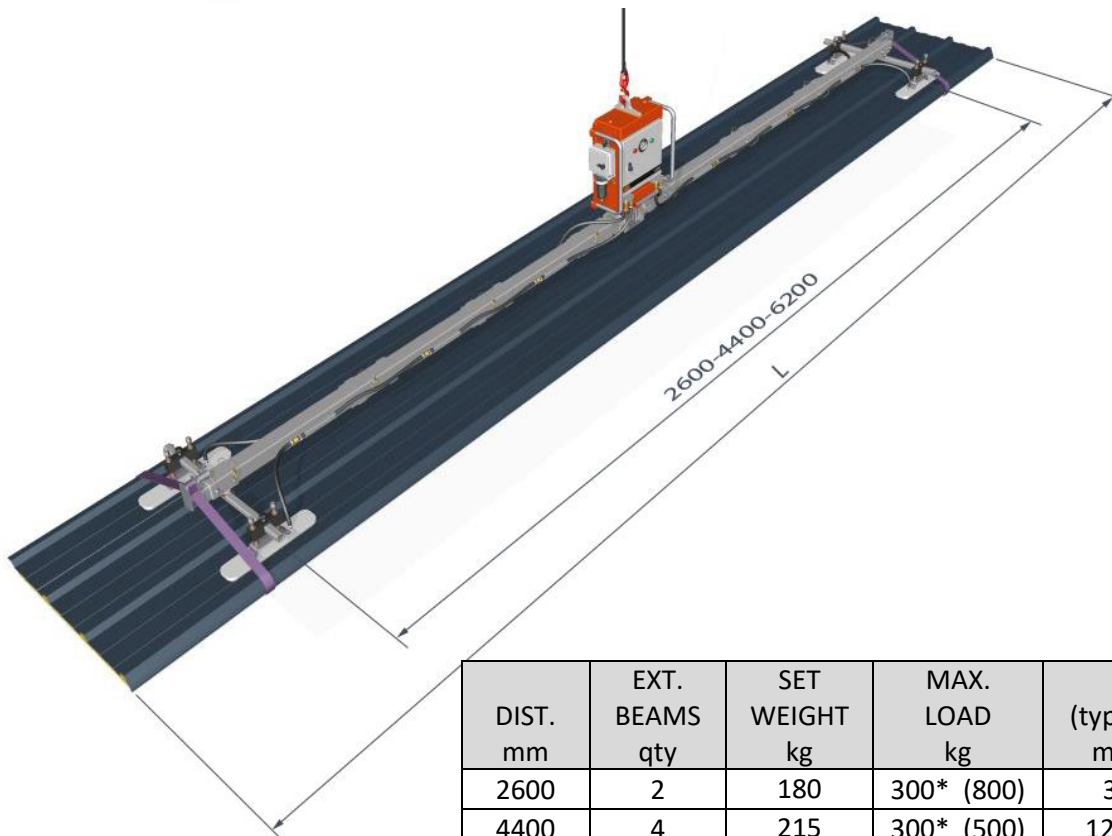

DIST. mm	EXT. BEAMS qty	SET WEIGHT kg	MAX. LOAD kg	L (type RA) meter	L (type RB) meter
2600	2	180	300* (800)	3 ...12	3 ... 8
4400	4	215	300* (500)	12 ...14	8 ...10
6200	6	250	300* (300)	14 ... 16	10 ...12

. . . *= load with 4x75kg pads, (. . .) = max. possible load on traverse.
 Type RA = roof panels with min.0,5mm steel skin & EPS/PUR/PIR core.
 Type RB = roof panels with min. 0,5mm steel skin & mineral wool core.
 Max. wind speeds L = up to 12 meter 11m/s, 12 up to 16 meter 9m/s.

REMARKS

- Panels with a length up to 20 meter are possible with configuration type RC 8000 - 9800.
- Panels with a roof pitch 25° up to 45° are possible with configuration RT 2600 - 4400 – 6200

CB4 configuration type: R4400-K4, R6200-K4

For roof panels up to 16 meter length

Roof pitch 0 25°

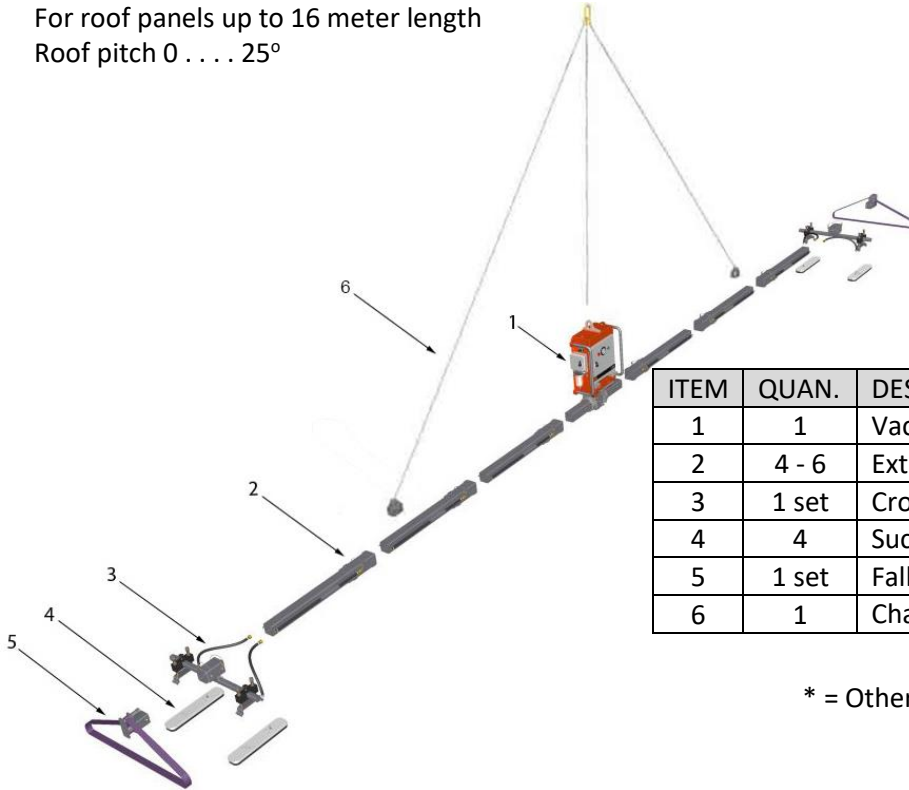

ITEM	QUAN.	DESCRIPTION	ART. NR
1	1	Vacuum module CB4	408500
2	4 - 6	Extension beam	408003
3	1 set	Cross traverse	408501
4	4	Suction pad 110x530, 75kg	402502*
5	1 set	Falling safety device FS4	408007
6	1	Chain suspension K4	257211

* = Other type of suction pads on request.

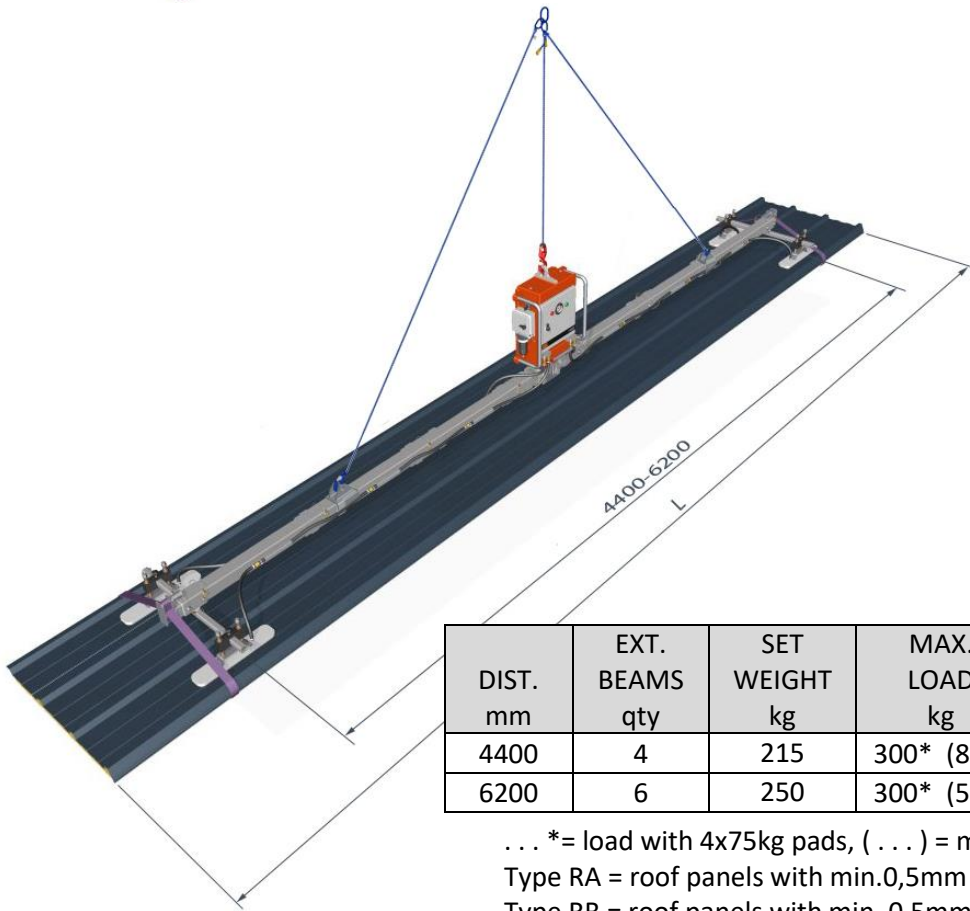

DIST. mm	EXT. BEAMS qty	SET WEIGHT kg	MAX. LOAD kg	L (type RA) meter	L (type RB) meter
4400	4	215	300* (800)	12 ...14	8 ...10
6200	6	250	300* (500)	14 ... 16	10 ...12

. . . *= load with 4x75kg pads, (. . .) = max. possible load on traverse.
 Type RA = roof panels with min.0,5mm steel skin & EPS/PUR/PIR core.
 Type RB = roof panels with min. 0,5mm steel skin & mineral wool core.
 Max. wind speeds L = up to 12 meter 11m/s, 12 up to 16 meter 9m/s.

REMARKS

- Panels with a length up to 20 meter are possible with configuration type RC 8000 - 9800.
- Panels with a roof pitch 25° up to 45° are possible with configuration RT 2600 - 4400 – 6200

CB4 configuration type: R8000-K8, R9800-K8

For roof panels up to 20 meter length

Roof pitch 0 25°

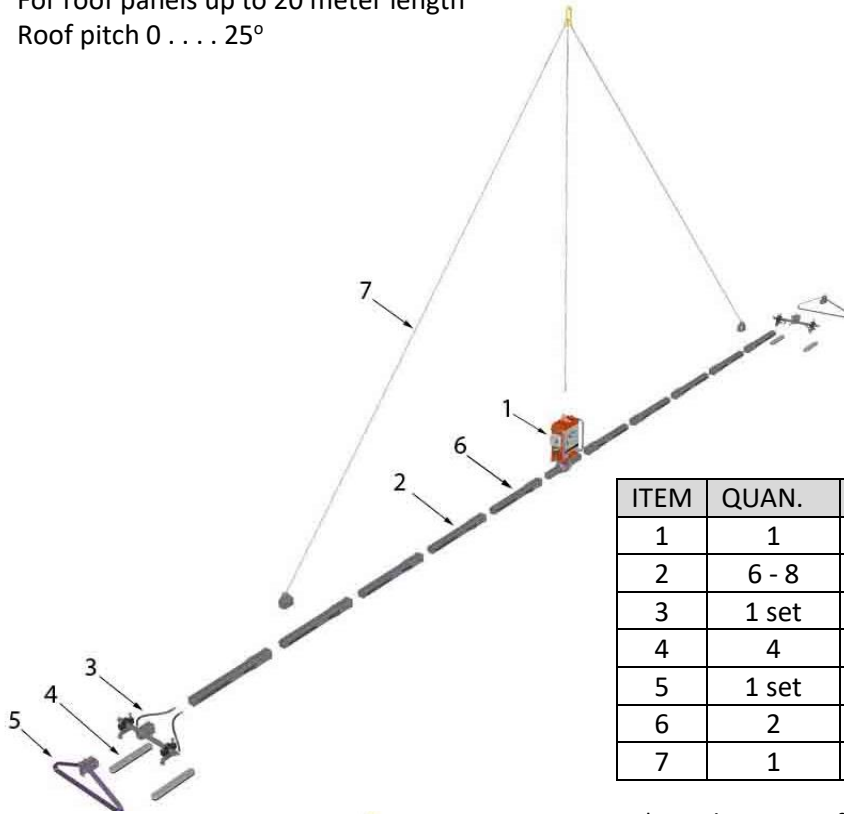

ITEM	QUAN.	DESCRIPTION	ART. NR
1	1	Vacuum module CB4	408500
2	6 - 8	Extension beam	408003
3	1 set	Cross traverse	408501
4	4	Suction pad 110x530, 75kg	402502*
5	1 set	Falling safety device FS4	408007
6	2	Bended extension beam	408004
7	1	Chain suspension K8/K10	408050

* = Other type of suction pads on request.

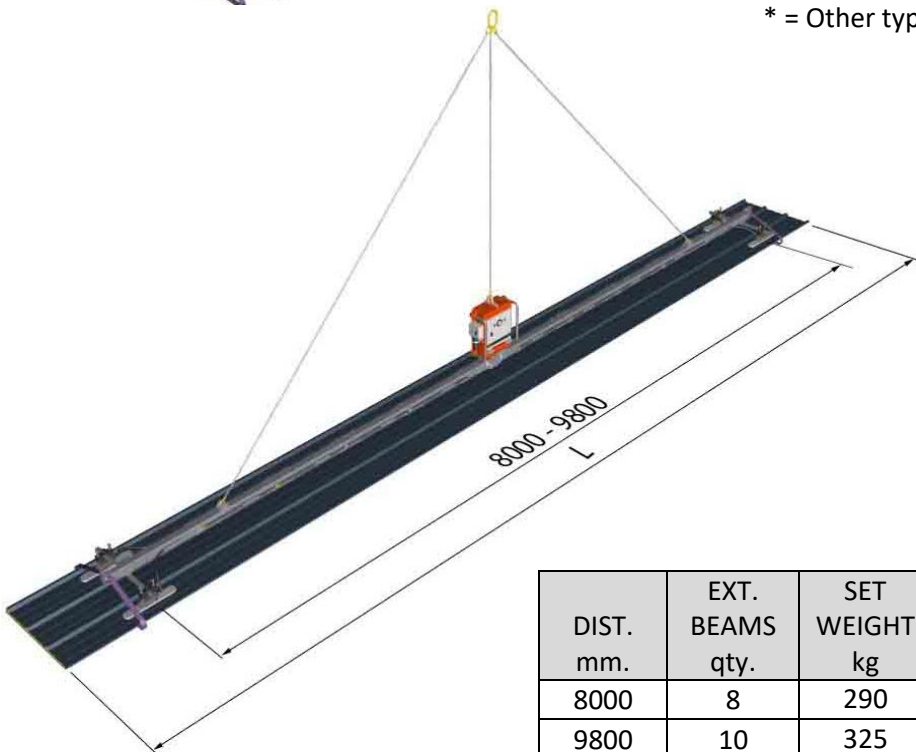

DIST. mm.	EXT. BEAMS qty.	SET WEIGHT kg	MAX. LOAD kg	L (type RA) meter	L (type RB) meter
8000	8	290	300* (500)	16 ... 18	Not advisable
9800	10	325	300* (500)	18 ... 20	Not advisable

. . . *= load with 4x75kg pads, (. . .) = max. possible load on traverse.
 Type RA = roof panels with min.0,5mm steel skin & PUR/PIR core.
 Type RB = roof panels with min. 0,5mm steel skin & mineral wool core.
 Max. wind speeds L = 16 up to 20 meter 8m/s.

REMARKS

- Panels with shorter lengths are possible with configuration type R 2600 - 4400 - 6200.
- Panels with a roof pitch 25° up to 45° are possible with configuration RT 2600 - 4400 – 6200.

CB4 configuration type: R8000/2600-K8, R9800/2600-K8

For roof panels up to 20 meter length

Roof pitch 0 25°

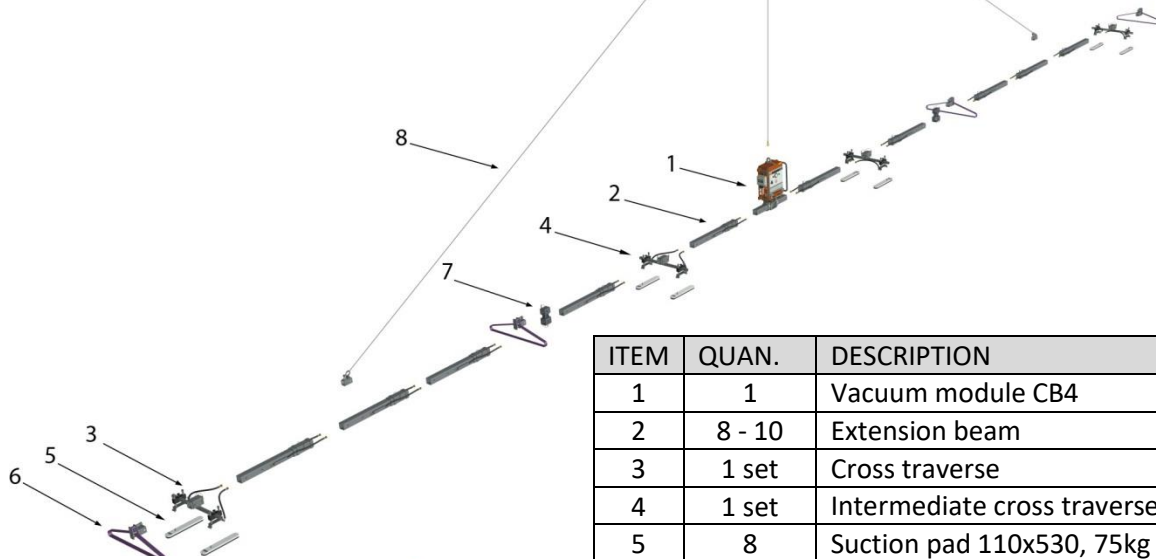

ITEM	QUAN.	DESCRIPTION	ART. NR
1	1	Vacuum module CB4	408500
2	8 - 10	Extension beam	408003
3	1 set	Cross traverse	408501
4	1 set	Intermediate cross traverse	408502
5	8	Suction pad 110x530, 75kg	402502*
6	2 set	Falling safety device FS4	408007
7	2	Safety strap mounting	408016
8	1	Chain suspension K8/K10	408050

* = Other type of suction pads on request.

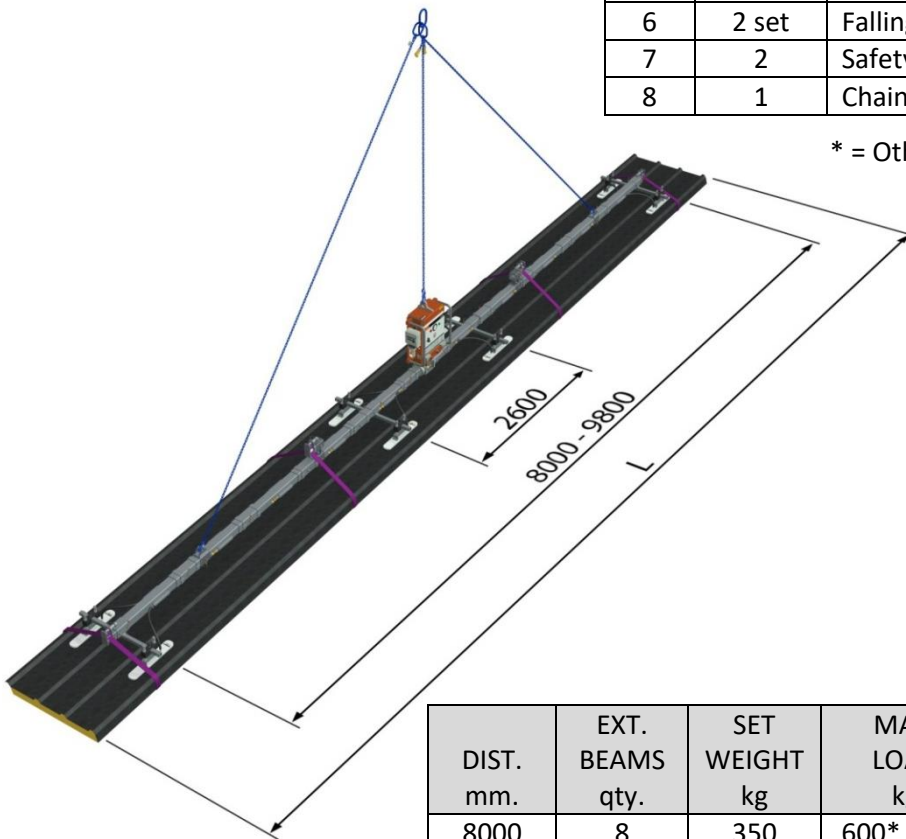

DIST. mm.	EXT. BEAMS qty.	SET WEIGHT kg	MAX. LOAD kg	L (type RA) meter	L (type RB) meter
8000	8	350	600* (800)	16 ... 18	12 ... 14
9800	10	385	600* (500)	18 ... 20	14 ... 16

. . . * = load with 8x75kg pads, (. . .) = max. possible load on traverse.
 Type RA = roof panels with min.0,5mm steel skin & PUR/PIR core.
 Type RB = roof panels with min. 0,5mm steel skin & mineral wool core.
 Max. wind speeds L = 16 up to 20 meter 8m/s.

REMARKS

- Panels with shorter lengths are possible with configuration type R 2600 - 4400 – 6200, RC 8000 - 9800.
- Panels with a roof pitch 25° up to 45° are possible with configuration RT 2600 - 4400 – 6200.

CB4 configuration type: R15200/6200-K8K16, R17000/6200-K8K16

For roof panels up to 26 meter length

Roof pitch 0 25°

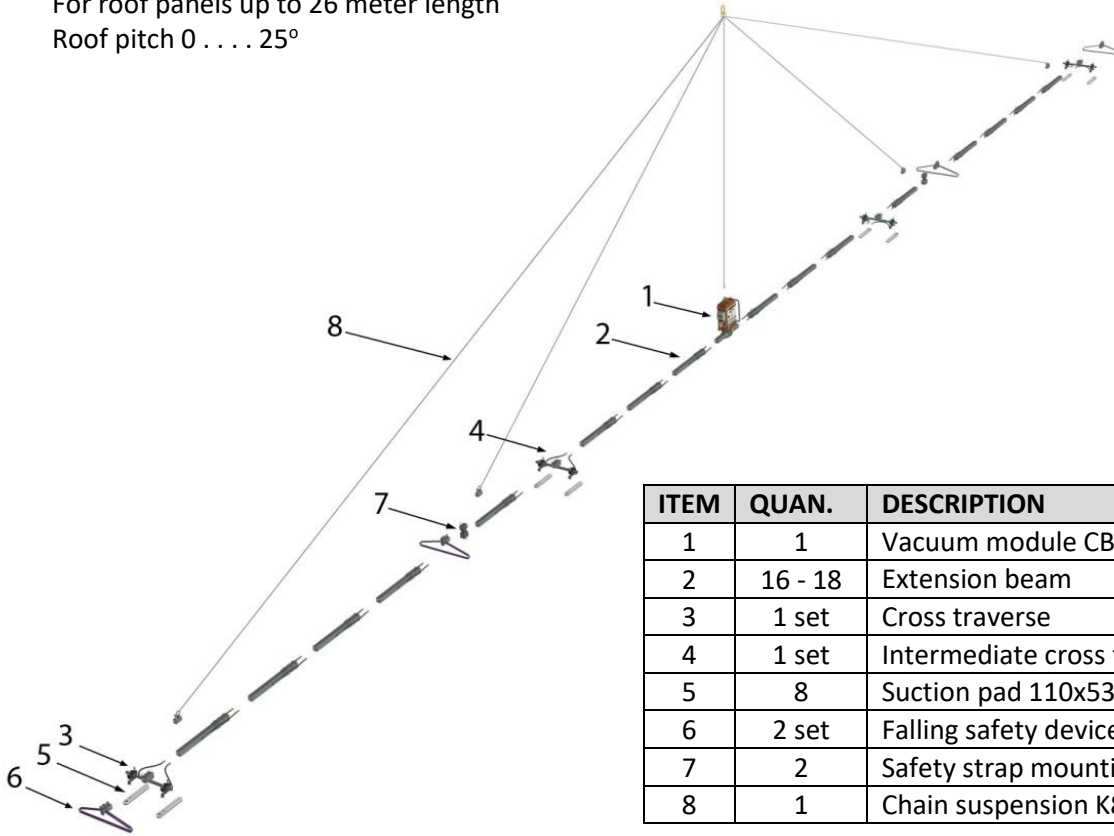

ITEM	QUAN.	DESCRIPTION	ART. NR
1	1	Vacuum module CB4	408500
2	16 - 18	Extension beam	408003
3	1 set	Cross traverse	408501
4	1 set	Intermediate cross traverse	408502
5	8	Suction pad 110x530, 75kg	402502*
6	2 set	Falling safety device FS4	408007
7	2	Safety strap mounting	408016
8	1	Chain suspension K8K16	257210

* = Other type of suction pads on request.

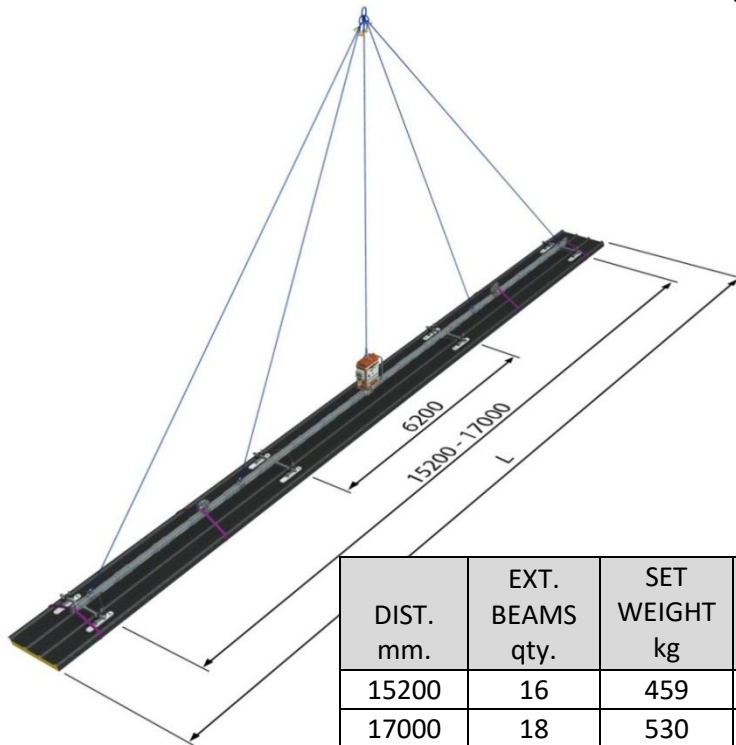

DIST. mm.	EXT. BEAMS qty.	SET WEIGHT kg	MAX. LOAD kg	L (type RA) meter	L (type RB) meter
15200	16	459	600* (500)	18 ... 24	16 ... 21
17000	18	530	300* (500)	20 ... 26	19 ... 23

. . . *= load with 8x75kg pads, (. . .) = max. possible load on traverse.
 Type RA = roof panels with min.0,5mm steel skin & PUR/PIR core.
 Type RB = roof panels with min. 0,5mm steel skin & mineral wool co
 Max. wind speeds L = up to 20 meter 8m/s, 20 up to 26 meter 6m/s.

REMARKS

- Panels with shorter lengths are possible with configuration type R 2600 - 4400 – 6200, RC 8000 - 9800.
- Panels with a roof pitch 25° up to 45° are possible with configuration RT 2600 - 4400 – 6200.

CB4 configuration type: RT2600, RT4400, RT6200

For roof panels up to 16 meter length

Roof pitch 25 45°

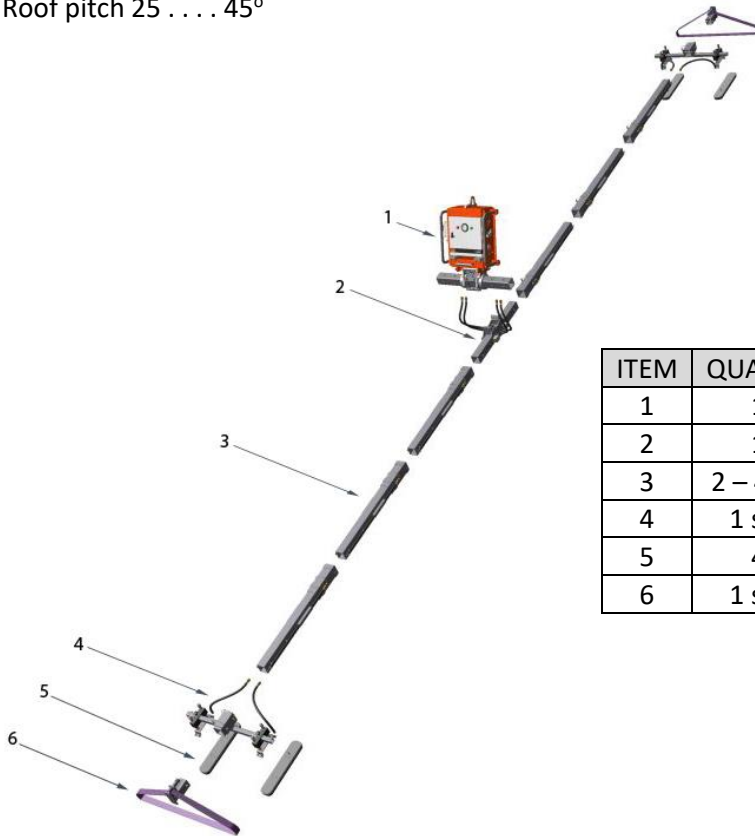

ITEM	QUAN.	DESCRIPTION	ART. NR
1	1	Vacuum module CB4	408500
2	1	Tilting beam	408006
3	2 – 4 - 6	Extension beam	408003
4	1 set	Cross traverse	408501
5	4	Suction pad 110x530, 75kg	402502*
6	1 set	Falling safety device FS4	408007

* = Other type of suction pads on request.

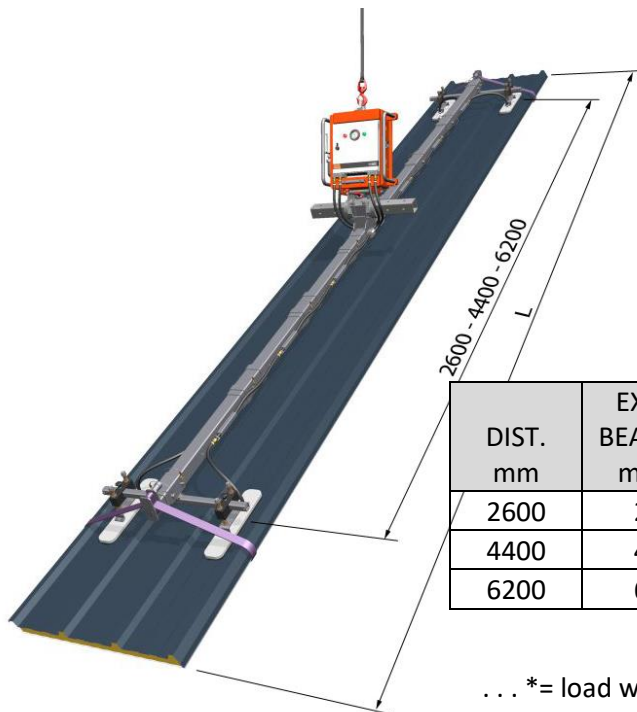

DIST. mm	EXT. BEAMS mm	SET WEIGHT kg	MAX. LOAD* kg	L (type RA) meter	L (type RB) meter
2600	2	205	300* (800)	3 ...12	3 ... 8
4400	4	240	300* (500)	12 ...14	8 ...10
6200	6	275	300* (300)	14 ... 16	10 ...12

. . . *= load with 4x75kg pads, (. . .) = max. possible load on traverse.
 Type RA = roof panels with min.0,5mm steel skin & PUR/PIR core.
 Type RB = roof panels with min. 0,5mm steel skin & mineral wool core
 Max. wind speeds L = up to 12 meter 8m/s, 12 up to 16 meter 6m/s.

REMARKS

- Panels with a roof pitch 0° up to 25° are possible with configuration R 2600 - 4400 - 6200
- Panels with a length up to 20 meter are possible with configuration type RC 8000 - 9800.

TYPE SANDWICH WALL PANELS

type **WA** (1)



0,5 .. 0.7mm Steel / aluminium

PUR / EPS

0,5 .. 0.7mm Steel / aluminium

type **WB** (2)



0,5 .. 0.7mm Steel / aluminium

Mineral wool

0,5 .. 0.7mm Steel / aluminium

CB4 configuration type: WV

For vertical wall panels up to 12 meter length

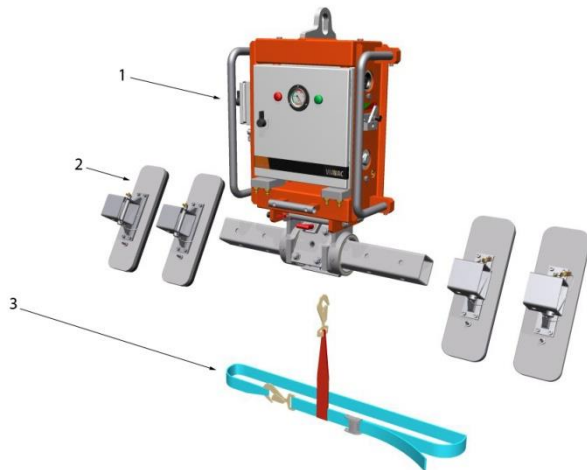

ITEM	QUAN.	DESCRIPTION	ART. NR
1	1	Vacuum unit CB4	408500
2	2 - 4	Suction pad with suspension	408033*
3	1	Falling safety strap with hook	17004

* = Other type of suction pads on request.

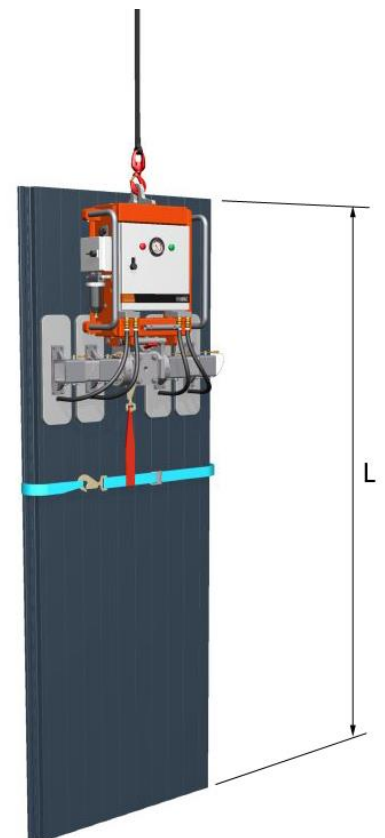

DIST. mm	SUCTION PADS qty	SET WEIGHT kg	MAX. LOAD kg	L (type WA) meter	L (type WB) meter
-	1 set	115	200* (800)	3 ...12	3 ... 8
-	2 set	130	400* (800)	3 ...12	3 ... 8

... *= load with 4x100kg pads, (. . .) = max. possible load on traverse.
 Type WA = wall panels with min.0,5mm skin & PUR/PIR core.
 Type WB = wall panels with min. 0,5mm steel skin & mineral wool core

REMARKS

* Panels with a length up to 17 meter are possible with CB configuration type WVK 2900 - 4700.

CB4 configuration type: WVK 2900 - 4700

For vertical wall panels up to 17 meter length

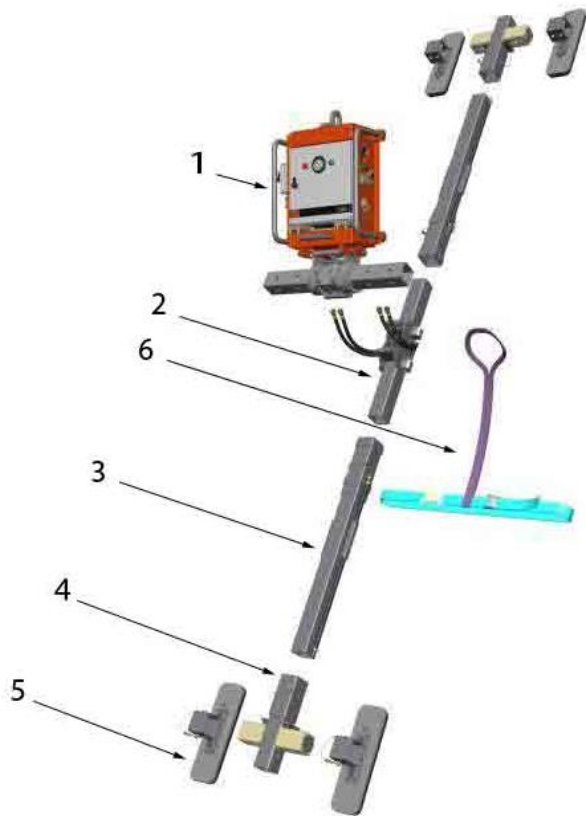

ITEM	AANTAL	DESCRIPTION	ART. NR
1	1	Vacuum unit CB4	408500
2	1	Tilting beam	408006
3	2 - 4	Extension beam	408003
4	1 set	Traverse cross	408010
5	2 set	Suction pad with suspension	408033*
6	1 set	Falling safety with sling	17003

* = Other type of suction pads on request.

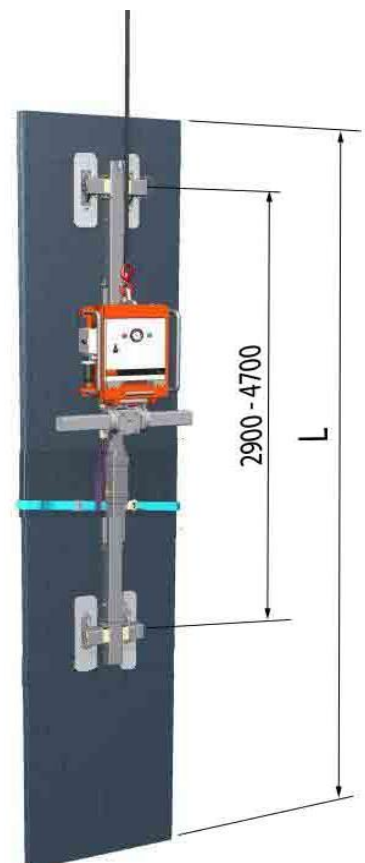

DIST. mm	EXT. BEAMS qty.	SET WEIGHT kg	MAX. LOAD kg	L (type WA) meter	L (type WB) meter
2900	2	225	400* (800)	13 ...15	9 ... 11
4700	4	260	400* (500)	15 ...17	11 ... 13

... *= load with 4x100kg pads, (. . .) = max. possible load on traverse.

Type WA = wall panels with min.0,5mm skin & PUR/PIR core.

Type WB = wall panels with min. 0,5mm steel skin & mineral wool core

REMARKS

* Panels with a length up to 12 meter are possible with CB configuration type WV.

CB4 configuration type: WH

For horizontal wall panels up to 12 meter length

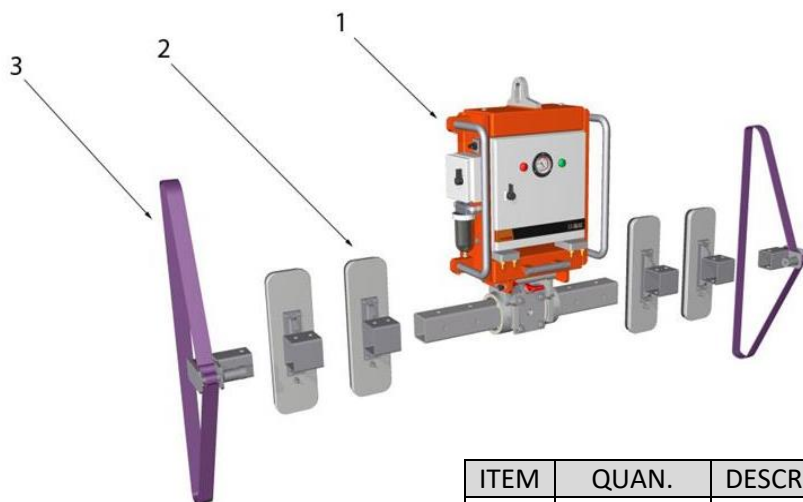

ITEM	QUAN.	DESCRIPTION	ART. NR
1	1	Vacuum unit CB4	408500
2	1 – 2 sets	Suction pad with suspension	408033*
3	1 set	Falling safety device FS4	408007

* = Other type of suction pads on request.

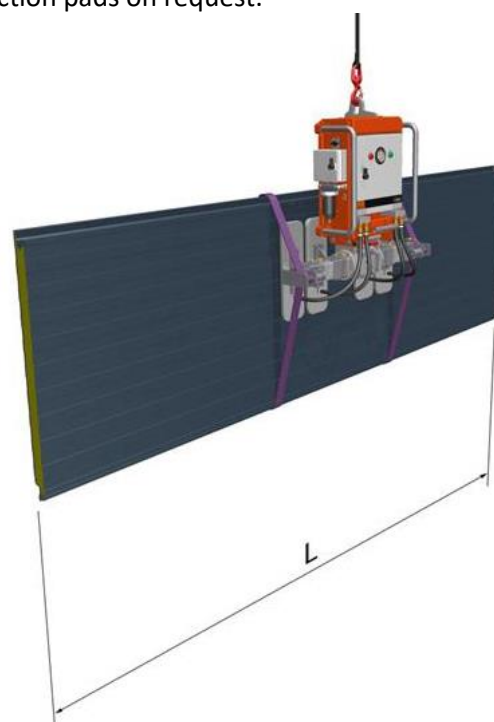

DIST. mm	SUCTION PADS qty	SET WEIGHT kg	MAX. LOAD kg	L (type WA) meter	L (type WB) meter
-	1 set	125	200* (800)	3 ...12	3 ... 8
-	2 set	140	400* (800)	3 ...12	3 ... 8

... *= load with 4x100kg pads, (. . .) = max. possible load on traverse.

Type WA = wall panels with min.0,5mm skin & PUR/PIR core.

Type WB = wall panels with min. 0,5mm steel skin & mineral wool core

REMARKS

* Panels with a length up to 15 meter are possible with configuration type WH 1100 - 2900.

CB4 configuration type: WH 1100 - 2900

For horizontal wall panels up to 15 meter length

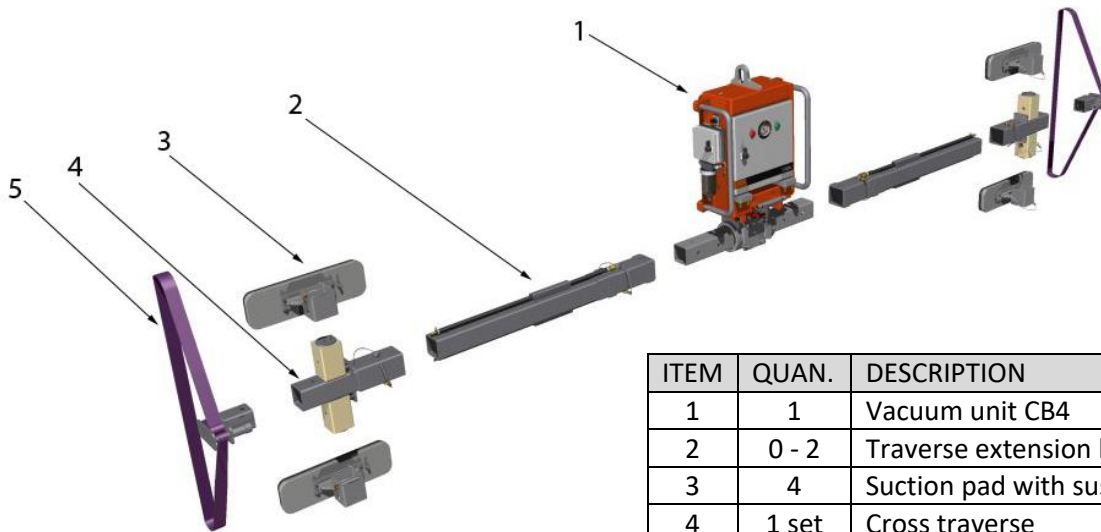

ITEM	QUAN.	DESCRIPTION	ART. NR
1	1	Vacuum unit CB4	408500
2	0 - 2	Traverse extension beam	408003
3	4	Suction pad with suspension	408033*
4	1 set	Cross traverse	408010
5	1 set	Falling safety device FS4	408007

* = Other type of suction pads on request.

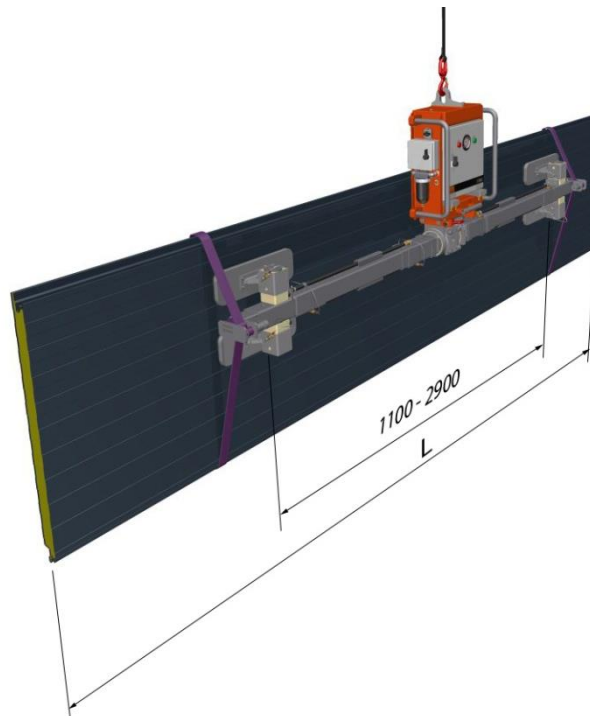

DIST. mm	EXT. BEAMS qty.	SET WEIGHT kg	MAX. LOAD kg	L (type WA) meter	L (type WB) meter
1100	0	160	400* (800)	3 ...13	3 ... 9
2900	2	195	400* (800)	13 ...15	9 ... 11

... *= load with 4x100kg pads, (. . .) = max. possible load on traverse.

Type WA = wall panels with min.0,5mm steel skin & PUR/PIR core.

Type WB = wall panels with min. 0,5mm steel skin & mineral wool core

REMARKS

* Panels with a length up to 12 meter are possible with configuration type WH.

B 7 Options

Main options are listed, these can also be found and ordered after registering at www.viavac.com/shop.

B 7.1 Falling safety devices



According CE regulation EN 13155 it is in all countries of the European union when a vacuum lifter is used at building site, a secondary safety system is obliged.

This can be realized in the following way's:

- One (single) vacuum circuit and the use of an falling safety device
- Two (dual) independent vacuum circuits.

This device is executed with 1 vacuum circuit and the use of an extra falling safety device is therefore obliged.

CB falling safety device for vertical wall panels

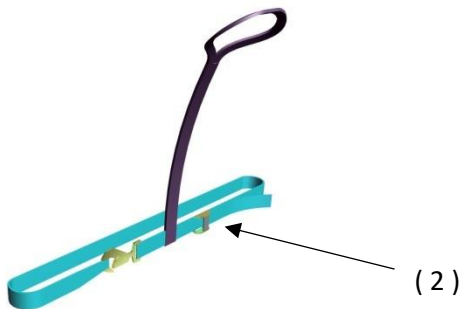

ITEM	QUAN.	DESCRIPTION	WEIGHT kg	ART. NR
1	1	Falling safety strap with sling 30/270/100	-	17003

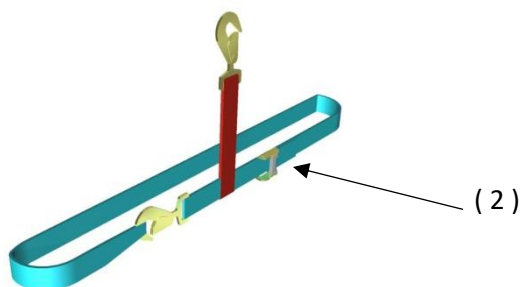

ITEM	QUAN.	DESCRIPTION	WEIGHT kg	ART. NR
1	1	Falling safety strap with hook 30/270/30	-	17004

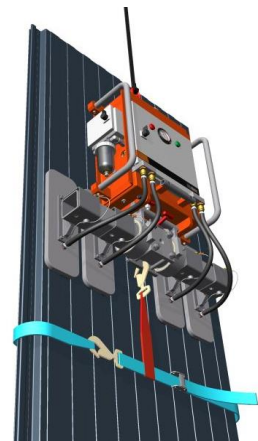

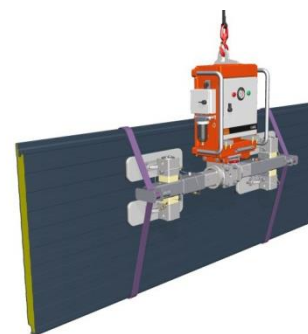
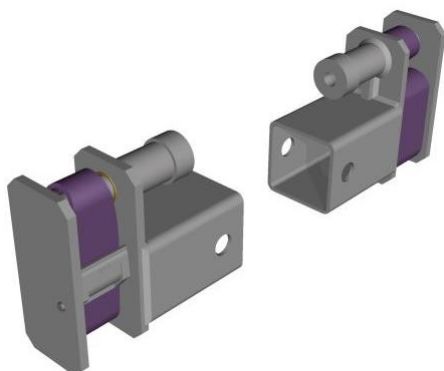
CB falling safety device for horizontal wall and roof panels

HORIZONTAL WALL PANELS

ITEM	QUAN.	DESCRIPTION	WEIGHT kg	ART. NR
1	1 set	Falling safety device FS4	8	408007

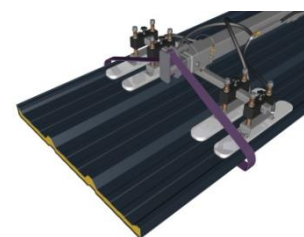

ROOF PANELS

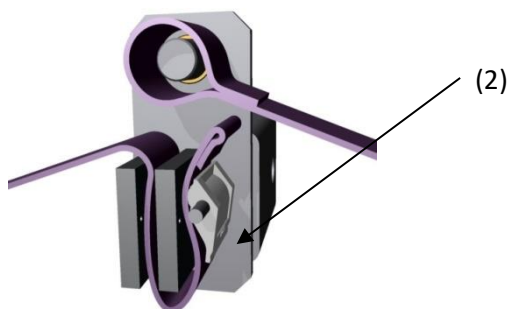

The falling safety devices are executed by means of lifting straps with hooks, which must be hooked to the device. During use the following must take place.

- 1 The correct falling safety device is hooked to the therefore intended fixing points on the device (1).
- 2 Lift the element with the vacuum lifter approx. 0,5 meter free from the ground.
- 3 Consequently the straps are at both ends put around the element as indicated above.
- 4 Through the clamp buckle (2) the strap is pulled tight around the element. (no clearance).
- 5 With the lifting device the whole unit is lifted to the designated place.
- 6 Just before the element is put in its place, the falling safety device is removed after which the element is placed on its spot.



1. Protect from sharp edges of the elements to be lifted at location of the straps.
2. If there are cracks or tears in the lifting straps, do not use them and replace them immediately.

B 7.2 CB tilting beam

The tilting beam is an accessory which makes it possible to install roof panels with an pith larger then 30° as well to install long vertical wall panels.



ITEM	QUAN.	DESCRIPTION	WEIGHT kg	ART. NR
1	1	Tilting beam	25	408006

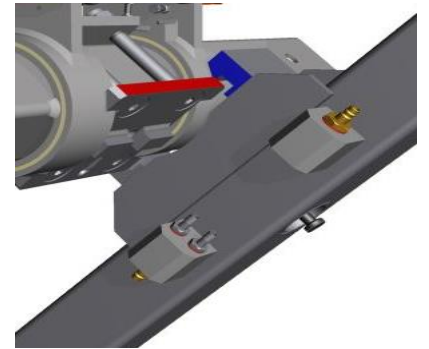

The tilting beam can be mounted without the use of tools. It slides over the mounting plate en locks itself by an integrated spring loaded securing pin. Because of the weight tilting beam we advise to do this with 2 persons.

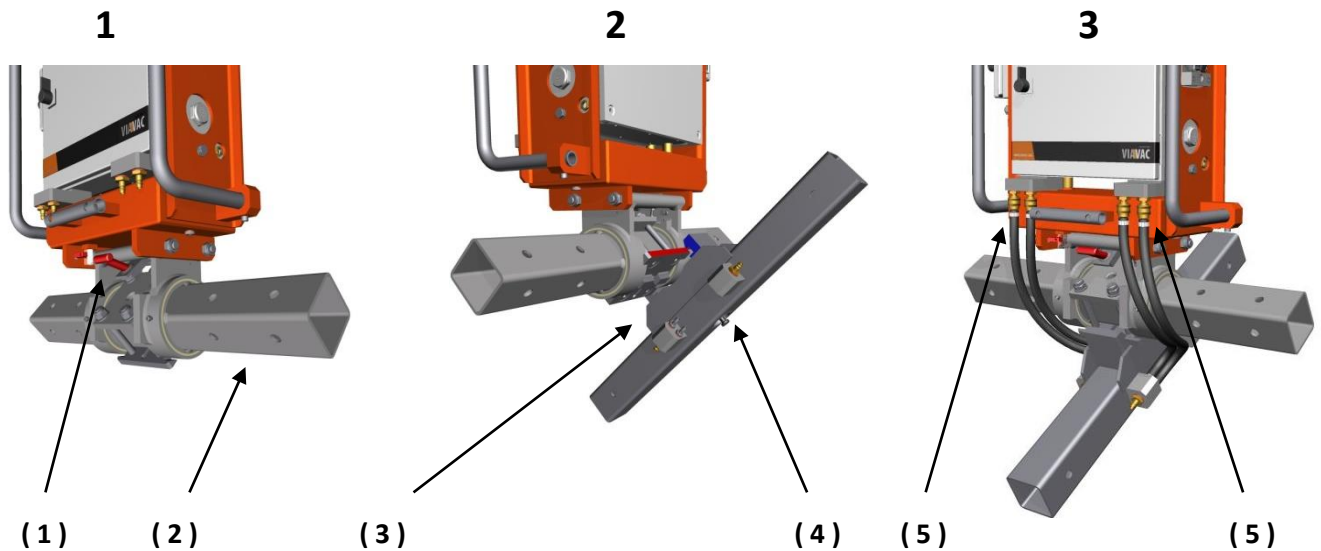

1. To be able to mount the tilting beam the traverse under the device has to be tilted approx 45° Therefore it has to be unlocked by lifting the securing handle (1) as indicated. Consequently the traverse can be rotated 45° .
2. The tilting beam (4) has to be slid over the entire length of the mounting plate, to achieve this you need to pull the securing pin simultaneously. When put in place the securing pin will lock the position of the tilting beam
3. Connect the vacuum hoses to the device.

Subsequently the extension beams and suction pads sets can be fitted along the tilting beam.

B 7.3 Adjustable suspension

Improves vertical hanging of thick and heavy horizontal wall panels.
Must be fitted to the standard lifting eye



ITEM	QUAN.	DESCRIPTION	WEIGHT kg	ART. NR
1	1	Adjustable suspension	5	290106

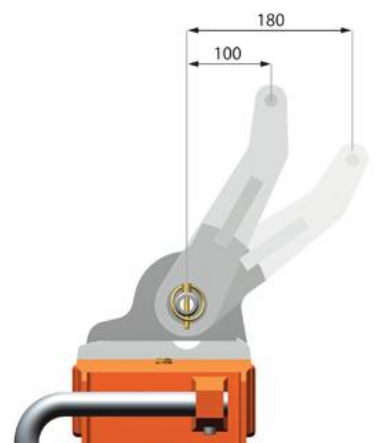
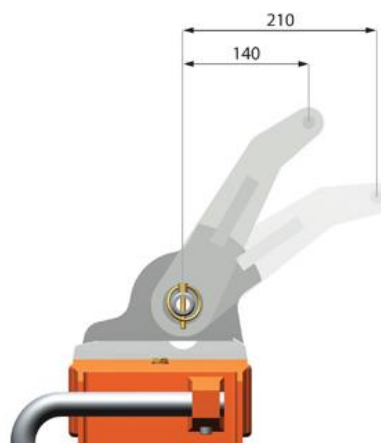
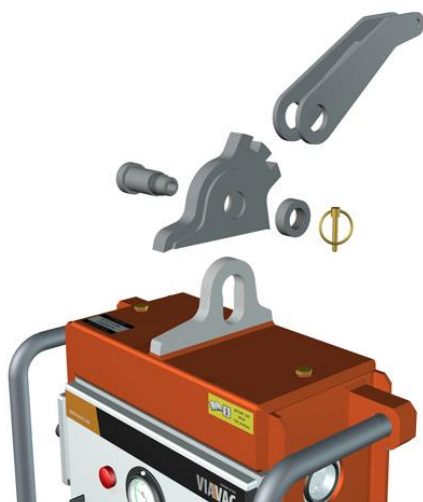

B 7.4 CB transportframe

Ideal to store and transport the device compact together with it's accessories within pallet size 120x100cm.

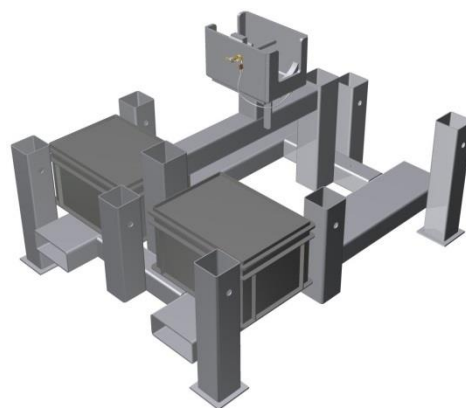

ITEM	QUAN.	DESCRIPTION	WEIGHT kg	ART. NR
1	1 set	Transport frame	130	408012

The vacuum unit has to be put with the tilting mechanism in the foundation bin, when the device can be attached to the frame by the securing pin (1).

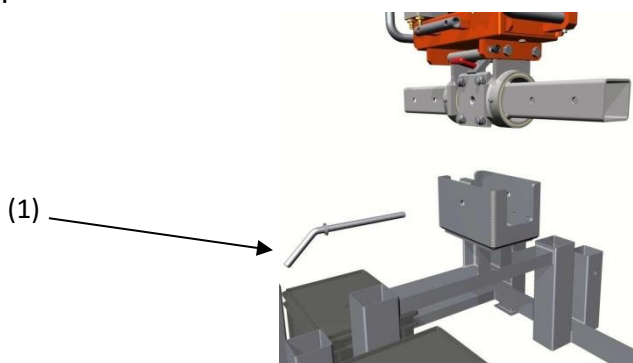

Subsequently all extension beams can be placed on the various foundation spots.

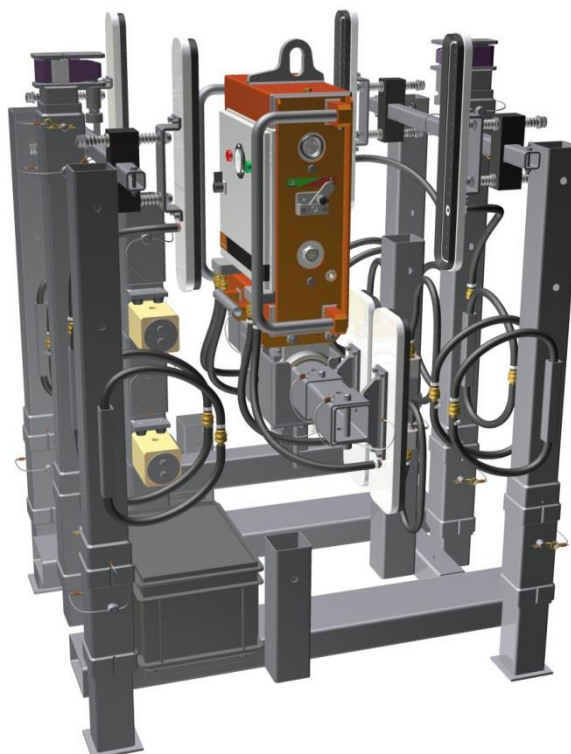

B 7.5 CB transport wheelset

The transport wheels are usefull to transport the unit without the use of a forklift or crane

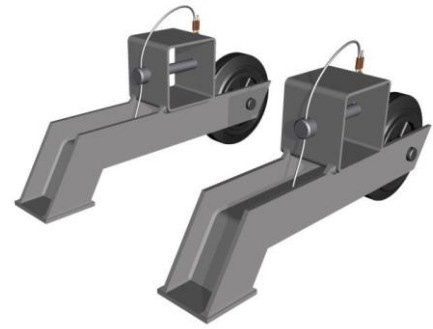

ITEM	QUAN.	DESCRIPTION	WEIGHT kg	ART. NR
1	1 set	Transport wheels	12	408011



B 8 Safety precautions

Recommendations

- 8.1 **Only** use this lifter when you have read and understood the operators section of this manual.
- 8.2 **Only** use this lifter when the main switch (10) for the power supply is turned “on” before lifting. (danger of lifting with the vacuum which is still in the vacuum tank.
- 8.3 **Always** check this lifter before use for its conditioning and correct functioning.
- 8.4 **Always** charge the battery before and after use.
- 8.5 **Always** take care that the contact area of the load is clean and dry before placing the suction pad on the surface.
- 8.6 **Always** position the suction pad correctly on the load.
- 8.7 **Always** put down the load immediately when the alarm sounds.
- 8.8 **Always** the operator should be within sight- and hearing distance of the lifter and the operator of the lifting machine.
- 8.9 **Always** there should be an agreement about the communication between the operator of the vacuum lifter and the lifting machine.
- 8.10 **Always** wear protective equipment that is appropriate for the material being handled. Follow trade association guidelines.
- 8.11 **Always** keep the device periodically checked and maintained by an expert
- 8.12 **Always** has the vacuum lifter to be examined within the period as prescribed by the safety regulations which are valid for the country where the vacuum lifter is in use.
- 8.13 **Always** remove all water, snow and ice at the suction pad area of the load.

Prohibitions

- 8.15 **Never** operate a lifter when it is damaged, malfunctioning, or has missing parts.
- 8.16 **Never** operate a lifter as the seal of the suction pad is damaged or cracked.
- 8.17 **Never** operate a lifter if the Load capacity or any warning appears to be missing or obscured.
- 8.18 **Never** exceed the Load Capacity which is indicated on the lifter.
- 8.19 **Never** attempt to lift a cracked or broken load with this lifter.
- 8.20 **Never** lift a load which is buckled.
- 8.21 **Never** lift a load when any vacuum indicator showing an inadequate vacuum.
- 8.22 **Never** lift a load when the alarm sounds.
- 8.23 **Never** lift a load higher than necessary.
- 8.24 **Never** leave suspended loads unattended.
- 8.25 **Never** lift a load over people
- 8.26 **Never** store the lifter standing on the suction pad.
- 8.27 **Never** lift a load at wind speeds exceeding 11 m/s.
- 8.28 **Never** lift a load when there is a chance for wind bursts.
- 8.29 **Never** release the load when the lifting sling or chain is not vertically above the vacuum lifter.
(danger of swinging of the lifter).
- 8.30 **Never** use the lifter when it's examined period has been exceeded.
- 8.31 **Never** use the lifter when the operator has a hearing loss or wears ear muffs.
- 8.32 **Never** use the device where the ambient noise exceeds the 70dB.
- 8.33 **Never** use solvents, petrol or other chemicals to clean the rubber parts of the suction pad.

C 2 Technical data

Model number	CB 4 / CB 4.1
Description	Below the hook vacuum lifter.
Application	Horizontal, vertical and inclined picking of rigid and non porous elements with a flat or slightly structured surface. The suction pad seal can compensate (when not too rough) unevenness's up to 5mm.
Functions	- 90° tilting mechanism.
Lifting capacity	max. 800kg (depending of configuration and the active suction pads) at -0.60 bar vacuum level.
Own weight	100kg
Dimensions	905x850x265
Power supply	Battery 12V / 50Ah
Battery charger	Primary 110 ... 240V / Secondary 12V-4A
Vacuum pump	2x Piston pump 12V capacity each 1,5m ³ per hour, max. ca -0.8 bar vacuum.
Safety features	- Secondary safety device. - Audible low vacuum warning. - Large vacuum buffer tank which prevents a sudden vacuum loss in case of leakage or break down of the vacuum pump. - Vacuum indicator with red / green indication.
Service life	At least 20.000 cycles, when used as intended.

C 3 Checking and maintenance

Checking, maintenance and repair activities must be executed by relevant expert technical personnel.

If your company does not have such expert personnel it can be executed by a VIAVAC expert.
Contact VIAVAC or your VIAVAC dealer for this.

Use only original VIAVAC parts in case of repair, because the properties and quality of these are guaranteed.

Modification of the device can influence the safety of the device and is therefore not allowed.



**If the above issues are not fulfilled this will lead to a risk for reliability and safe use
In this case VIAVAC can not accept any responsibility.**

Periodic checks and tests.

The activities and periods described hereafter pertain to the minimum requirements with regard to maintenance.

It is advisable to perform these activities more frequently if the circumstances make this necessary, such as with increased frequency of use resulting in more wear and tear, corrosion and/or an increased defect pattern.

Daily

- a. Check rubber sealing profile (15) for presence of wear and tears and replace, if necessary.
- b. Check whether rubber back plate (14) is clean and oil-free, and clean it if necessary.
- c. Check vacuum tightness.
- d. Mechanical status of the lifting eye and the pivoting points.
- e. Suction filter (at then side of the switch box).
- f. Functioning of the vacuum meter.
- g. Functioning of the acoustic alarm.
- h. When necessary remove water by using the drain tap (10).
- i. Check falling safety device for wear and tears and replace if necessary.

Monthly

- a. The same as the daily maintenance.
- b. Check control of the vacuum pump.
- c. Clean the rubber back plate of the suction pad with natural vinegar

Yearly

- a. The same as the monthly maintenance.
- b. Testing the battery capacity.
- c. Static test procedure.

3 yearly

- a. The same as the yearly maintenance.
- b. Replace suction pad rubber sealing profile.
- c. Replace battery because the capacity reduces over time.

Compulsory a regular inspection of the device must also take place.

This in accordance with the requirements from the authorities of the country where the device is used.

In the device there are no pivoting points or parts which require lubrication.

The vacuum pump is completely maintenance free and lubrication is not allowed.



In vertical position of the suction pad, the load is held by the friction between the rubber back plate of the suction pad and the load; therefore it is essential that this is clean, dry and oil-free. Monthly cleaning of the rubber back plate with natural vinegar ensures that the required friction between suction pad and the load remains retained.



Never use solvents, petrol or other chemical agents to clean the rubber of the suction pad.



Checks and repairs must be documented in writing; for this purpose the following forms can be found in this manual:

- C 4 Check and maintenance report.
- C 11 Maintenance history.

METHOD OF OPERATION:

Vacuum tightness	<p>Hereby the device must be put on a non porous sheet of glass, metal or plastic, after which suction is applied and waited until the pump stops running. Then the main switch is turned off and after waiting 1 minute it is then checked to which extend the vacuum level has decreased.</p> <p><u>The loss of vacuum may not amount to more than 10% per minute.</u></p>
Vacuum indicator	<p>Hereby the device must be put on a non porous sheet of glass, metal or plastic, after which suction is applied and waited until the pump stops running. Compare the value indicated by the pointer of the vacuum indicator with the value indicated by the digital vacuum switch (2).</p> <p><u>Indication from the vacuum meter may not deviate more than 3% from the digital value.</u></p>
Acoustic alarm	<p>Hereby the device must be put on a non porous sheet of glass, metal or plastic, after which suction is applied and waited until the pump stops running. By slowly opening the water drain valve (12), the system will be gradually aerated and the vacuum level will decrease.</p> <p><u>As soon as the vacuum level falls below the -0.60 bar the acoustic alarm should sound, the volume thereof should amount to at least 85db at 1 meter of distance.</u></p>
Control of the vacuum pump	<p>Hereby the device must be put on a non porous sheet of glass, metal or plastic, after which suction is applied and waited until the pump stops running. By slowly opening the water drain valve (12), the system will be gradually be aerated and the vacuum level will decrease.</p> <p>As soon as the vacuum level falls below the -0.65 bar the vacuum pump must start. <u>After 10 seconds the vacuum pump must automatically stop, whereby the digital vacuums switch must indicate a vacuum level of -0.70 bar or more.</u></p>
Battery capacity	<p>First the battery is fully charged with a battery charger, after which the battery is discharged with a certain amperage, by measuring the time needed for discharging, The battery capacity is determined by multiplying time and amperage.</p> <p><u>This needs to be 90% or more of the nominal battery capacity (55 AH).</u></p>
Static test	<p>With the suction cup in a vertical position, a (non porous) load with a weight equal to 2 times the working load limit should be lifted.</p> <p><u>The load should be held and after the removal of the load no visible permanent deformation of the device.</u></p>
Holding time test	<p>With the suction cup in a vertical position, a (non porous) load with a weight equal to the working load limit should be lifted.</p> <p>The main switch should be turned off so the vacuum pump will no longer run.</p> <p><u>The load should be held for at least 5 minutes.</u></p>

During the static test and the endurance test, the load should be lifted only a few millimeters so that in case of an unsuspected release, this will not result in damage or personal injury.

C 4 Inspection & maintenance report

Machine nr. :

Owner :

Type :

Contact person :

		<u>Limited value</u>	APPROVED				
			A	D	M	Y	3Y
1. Suction pads		Type	0				
Sealing profiles checked for cracks and wear.			0	0	0	0	0
Replace the sealing profile			-	-	-	-	0
Rubber back plate, cleaned and free from grease.			0	0	0	0	0
Rubber back plate cleaned with natural vinegar.			-	0	0	0	0
Replace the rubber backplate			-	-	-	-	0
2. Suction pads		Type	0				
Sealing profiles checked for cracks and wear.			0	0	0	0	0
Replace the sealing profile			-	-	-	-	0
Rubber back plate, cleaned and free from grease.			0	0	0	0	0
Rubber back plate cleaned with natural vinegar.			-	0	0	0	0
Replace the rubber backplate			-	-	-	-	0
3. Suction pads		Type	0				
Sealing profiles checked for cracks and wear.			0	0	0	0	0
Replace the sealing profile			-	-	-	-	0
Rubber back plate, cleaned and free from grease.			0	0	0	0	0
Rubber back plate cleaned with natural vinegar.			-	0	0	0	0
Replace the rubber backplate			-	-	-	-	0
Filter/water separator							
Remove water and dirt from bowl			0	0	0	0	0
Clean filter in bowl			-	-	0	0	0
Water							
Drain by opening valve (when used in rain)			0	0	0	0	0
Falling safety device for vertical wall panels			0				
Check for cracks and wear			0	0	0	0	0
Check mechanical condition and functioning			0	0	0	0	0
Falling safety device for horizontal wall and roof panels			0				
Check for cracks and wear			0	0	0	0	0
Check mechanical condition and functioning			0	0	0	0	0
Mechanical							
Check lifting eye			0	0	0	0	0
Check securing device from handle "suction/aeration"			0	0	0	0	0
Check main and cross traverses for cracks.			0	0	0	0	0
Check rotation of main traverse.			0	0	0	0	0
Check locking device of main traverse.			0	0	0	0	0
Alarm							
Acoustic alarm + illumination of red lamp at vacuum level < -0.60 bar (+/- 2%) 85db			0	0	0	0	0
Illumination of green lamp and switch off alarm at vacuum level of > -0.60 bar (+/- 2%)			0	0	0	0	0

Continues on the next page

(A = Available / D = Daily / M = Monthly / J = Yearly / 3 Yearly)

Continuation from previous page

	<u>Limited value</u>	APPROVED				
		A	D	M	Y	3Y
<u>Control of vacuum pump</u>						
Switching on at vacuum level -0.65 bar	+/- 2%	-	0	0	0	0
Time for switching off 10 sec after reaching vacuum level -0.65 bar	+/- 2 sec.	-	0	0	0	0
Vacuum level after switching off	min. 70%	-	0	0	0	0
<u>Sealed condition</u>						
Decrease of vacuum in non-sucked state	max. 3 % in 60 sec.	-	0	0	0	0
Decrease of vacuum level with wall panel suction pads in sucked state	max. 10 % in 60 sec.	-	0	0	0	0
Decrease of vacuum level with roof panel extension set in sucked state	max. 10 % in 60 sec.	-	0	0	0	0
<u>Vacuum indicator</u>						
Compare level of vacuum indicator with digital vacuum switch	+/- 0.03 bar	0	0	0	0	0
<u>Battery</u>						
Capacity test	min. 85% of 55Ah	-	-	0	0	0
Replace preventative		-	-	-	0	0
Charging current of battery charger	min. 13V	-	-	0	0	0
Level indicator (Voltmeter)	max. 1V difference	-	-	0	0	0
<u>Tests</u>						
Static load test	2x working load	0	0	0	0	0
Holding time test	min. 5 minutes	-	-	0	0	0
<u>Stickers</u>						
Presence of all stickers present		-	-	0	0	0
In readable condition		-	-	0	0	0
<u>Instruction manual</u>						
In readable condition		0	0	0	0	0
<u>Approval</u>						
Fill in this inspection and maintenance report and undersign for approval.		-	-	0	0	0
Fill in the maintenance record of the instruction manual.		-	-	0	0	0
When everything is approved, apply new certification sticker with date indication.		-	-	0	0	0

Remarks

(A = Available / D = Daily / M = Monthly / J = Yearly / 3 Yearly)

.....

.....

.....

.....

.....

.....

Inspection & maintenance executed by _____ : _____ Valid till : _____

C 5 Fitting sealing profile in suction pad

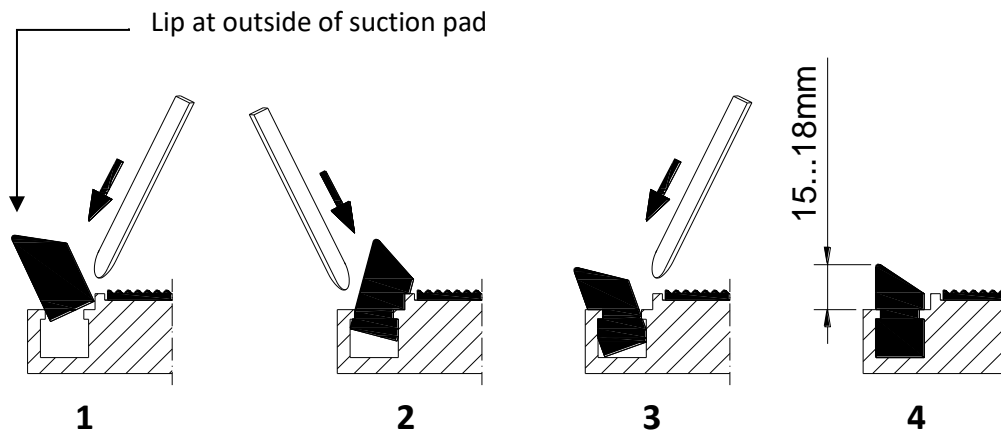

C 6 Mal functioning and repair

MAL FUNCTION ANALYSE

Fault	CAUSE	ACTION
1. No action and volt indicator shows 0	Battery very low	Charge battery or replace
	Fuse of the control current defect	Replace glassfuse
2. Insufficient vacuum level Acoustic alarm sounds	Sealing profile of suction pad is damaged	Replace sealing profile
	Load is from porous material	Move load in another way
	Surface is too rough	Move load in another way
	Battery is low	Charge battery or replace
3. Sufficient vacuum level Acoustic warning signal sounds	Relais K2 is defect	Replace relais K2
	Vacuum switch is deprogrammed	Re programm or replace
	Leakage of non return valve	Clean non return valve or replace
	Capacity of vacuum pump has decreased	Replace vacuum pump or valveplate in de vacuum pump
4. Sufficient vacuum level No acoustic warning signal but vacuum pump keeps running	Relais K1 is defect	Replace relais K1
	Vacuum switch is deprogrammed	Reprogram mor replace.
	Battery low	Charge or replace battery
	Vacuum leakage	Check and replace if necessary seal of suction pad
	Leakage of non return valve	Clean or replace non return valve
	Capacity of vacuum pump has decreased	Replace vacuum.
	Surface too rough or porous	Move load in another way
5. Vacuum pump does not run	Fuse of the electric motor is defect	Replace fuse.
	Vacuum pump defect	Repair or replace vacuum pump.

C7 Electric diagram

CB4

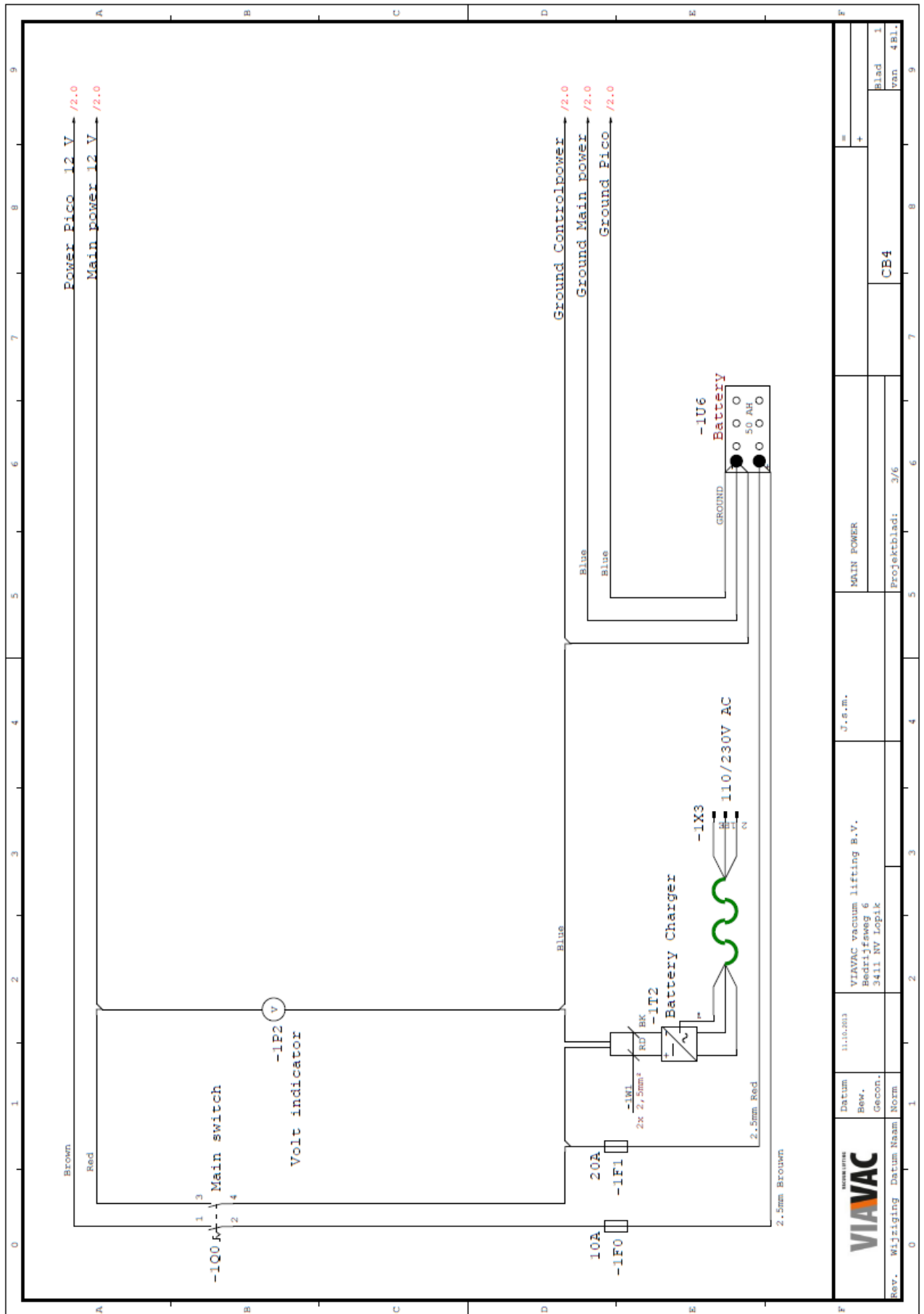

		Datum: 11.10.2013 Bew.: Gecon.	J. e. m. VIAVAC vacuum lifting B.V. Bedrijfsweg 6 3411 NV Lopik	MAIN POWER Projektblad: 3/6	CB4 Blad 1 van 4 Bl.
--	--	-----------------------------------	--	--------------------------------	-------------------------

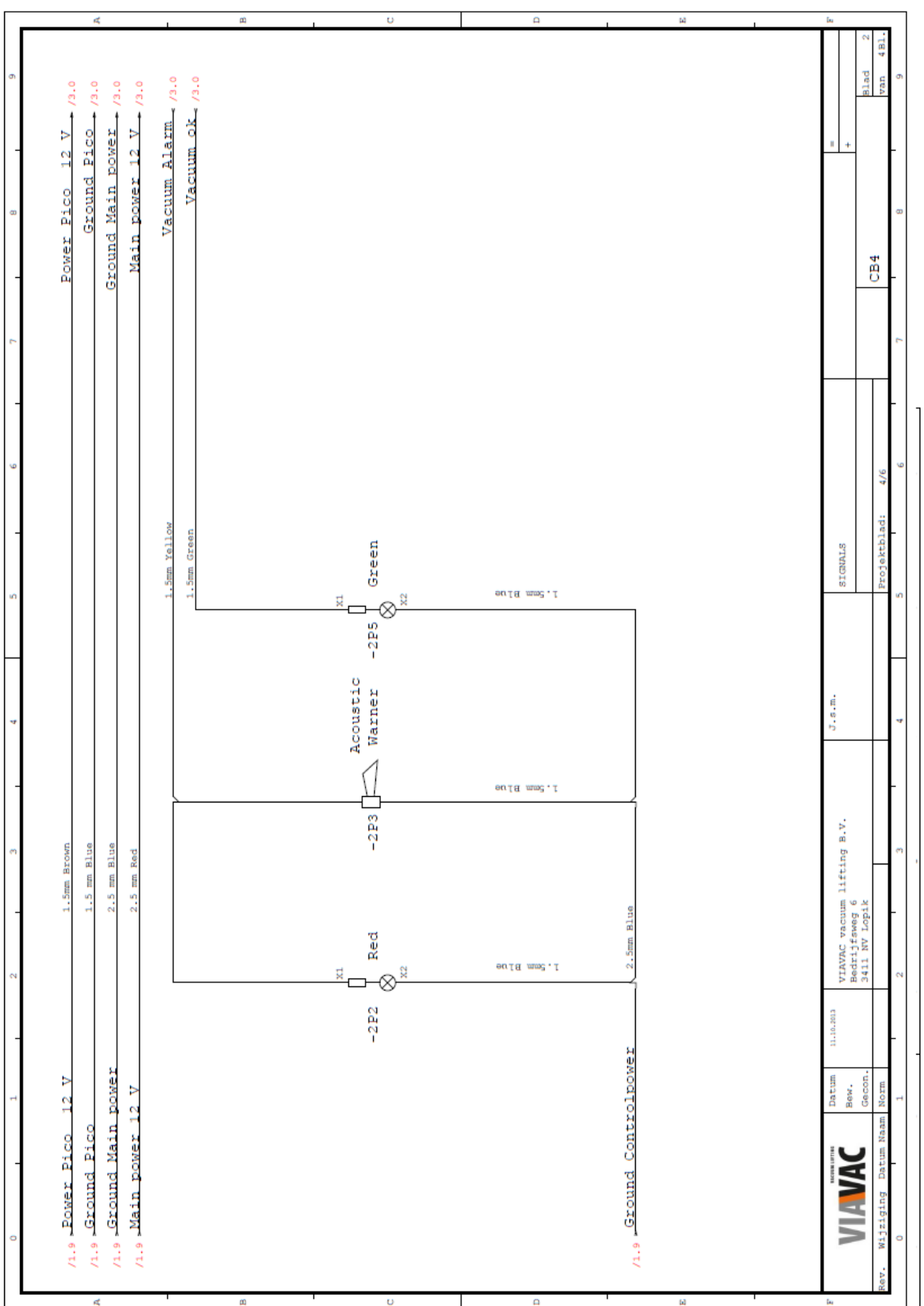

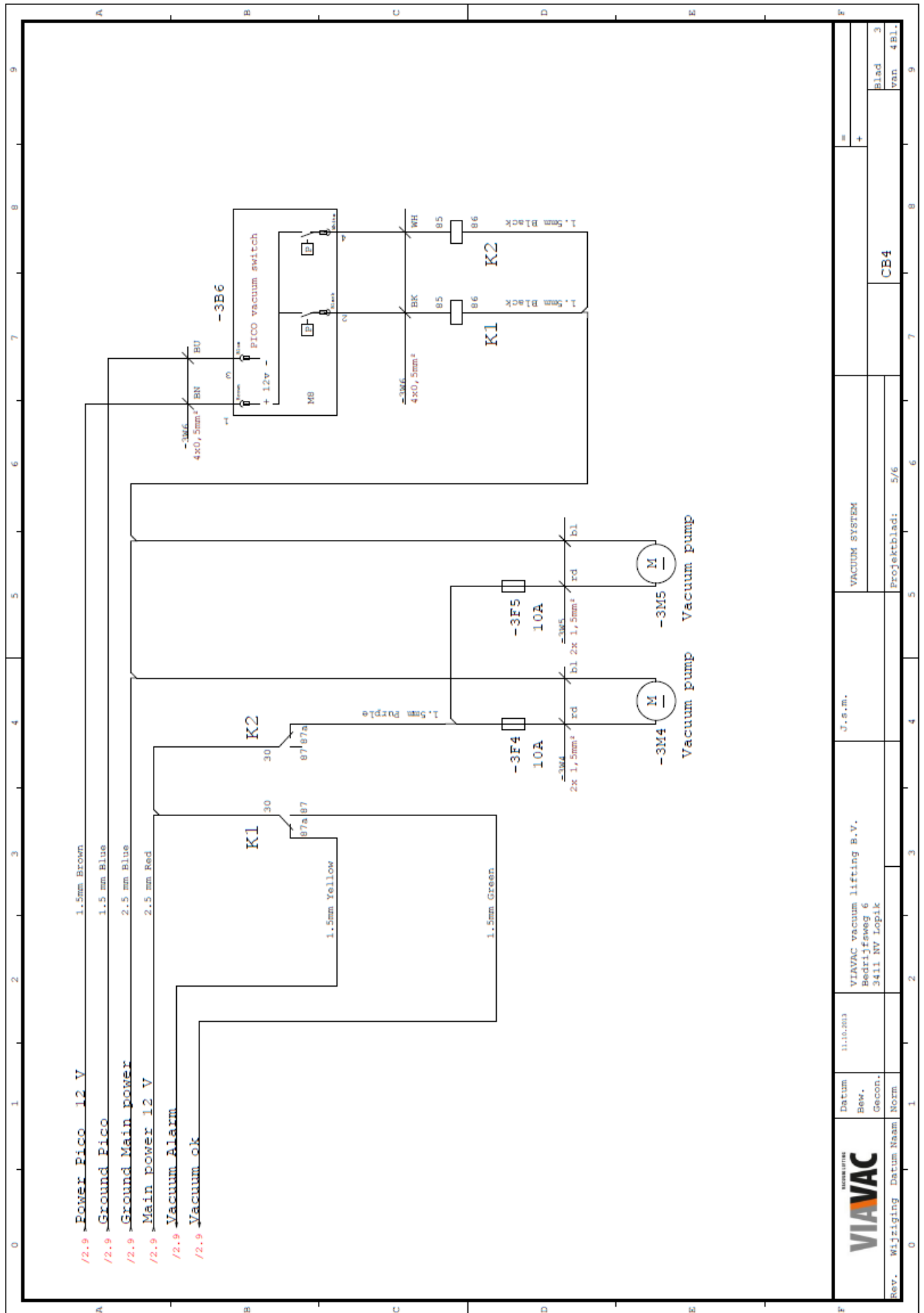

		Datum	11.10.2013	VIAVAC vacuum lifting B.V. Bedrijfsweg 6 3411 NV Lopik		J.G.M.		VACUUM SYSTEM	
Rev.	Afzetting	Datum Naam	Norm						
								CB4	
						Projectblad: 5/6		Blad 3 van 4 bl.	

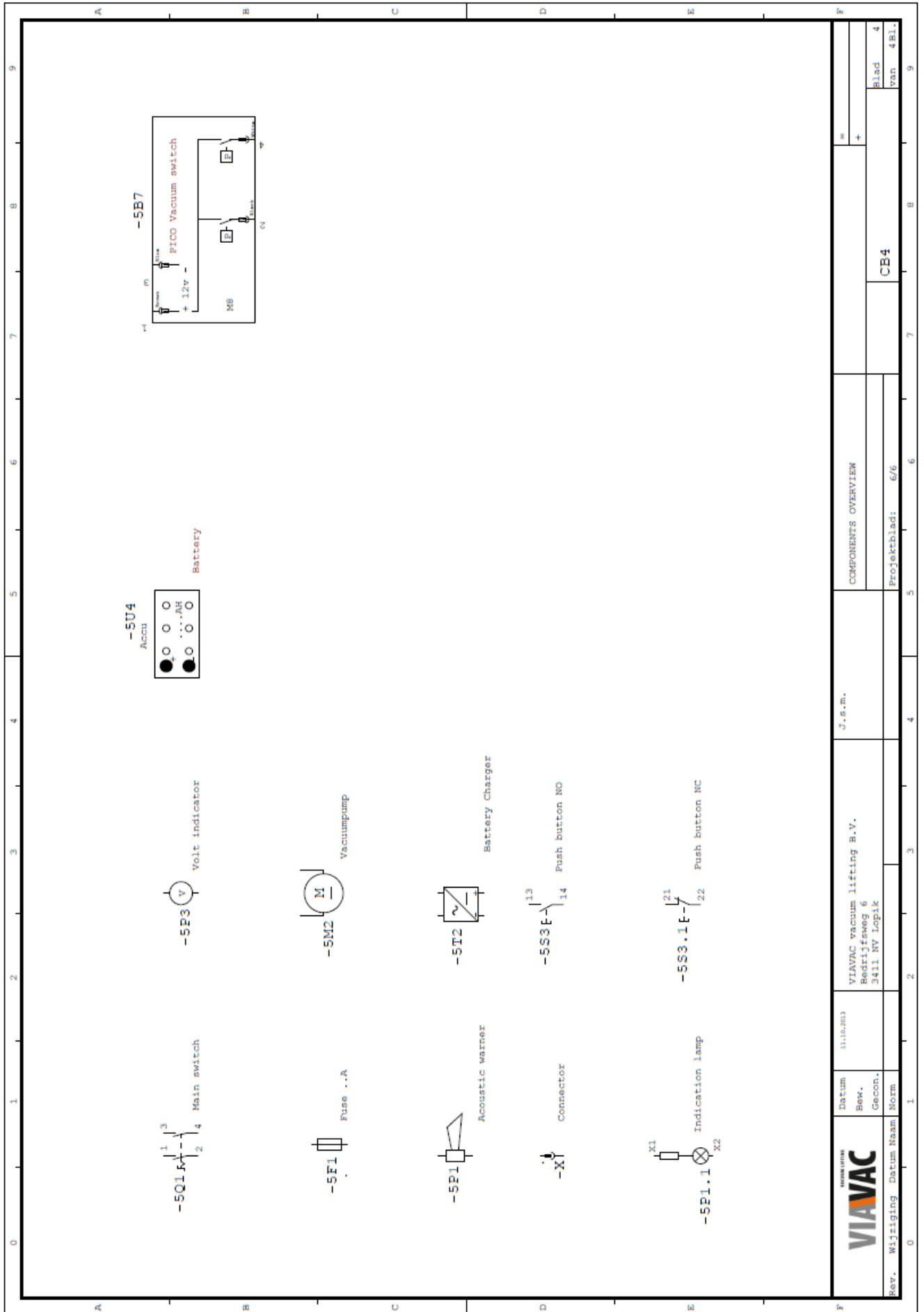

		Datum	11.10.2013	J.s.m. VIAVAC vacuum lifting B.V. Bedrijfsweg 6 3411 NV Lopik		COMPONENTS OVERVIEW Projektblad: 6/6		= + CB4		Blad van 4Bl.			
Rev.	Wijziging	Datum	Naam	Norm.	1	2	3	4	5	6	7	8	9

CB4.1

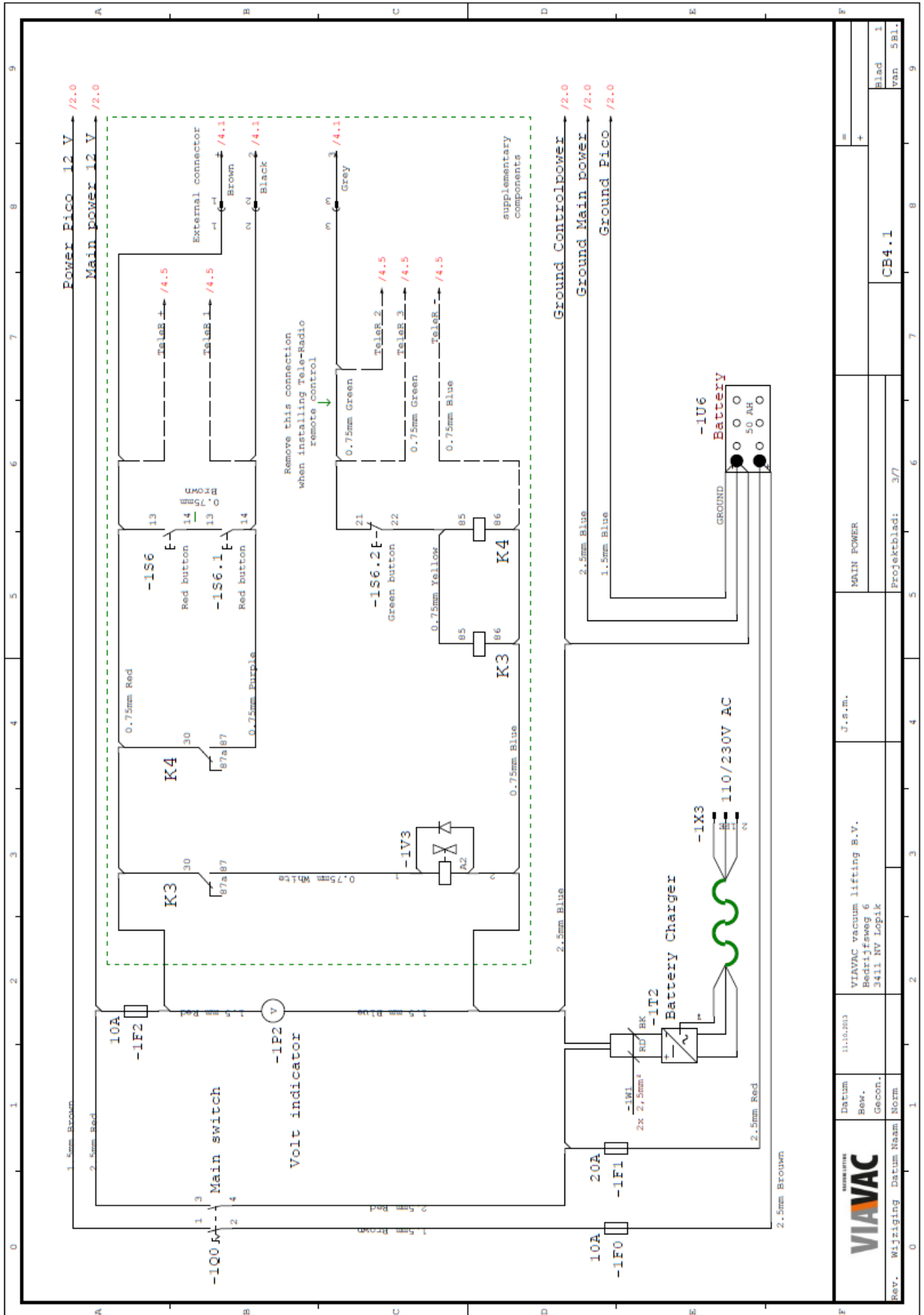

VIAVAC
 Datum 11.10.2013
 Rev. Gecon.
 Rev. Wjzigtig Datum Naam Norm

VIAVAC vacuum lifting B.V.
 Bedrijfsweg 6
 3411 NV Lopik

J.s.m.

MAIN POWER
 Projectblad: 3/7

CB4.1

Blad 1 van 5Bl.

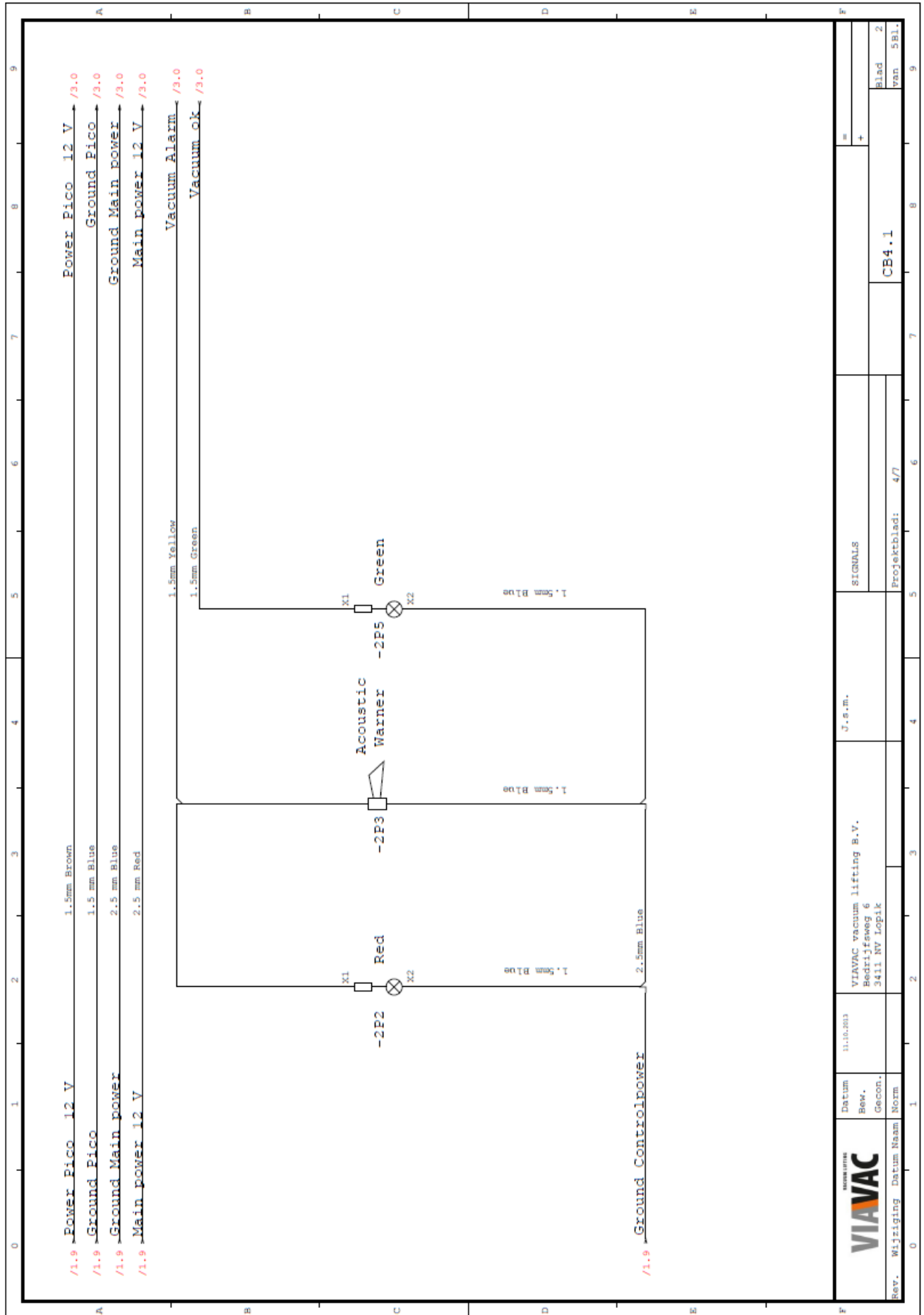

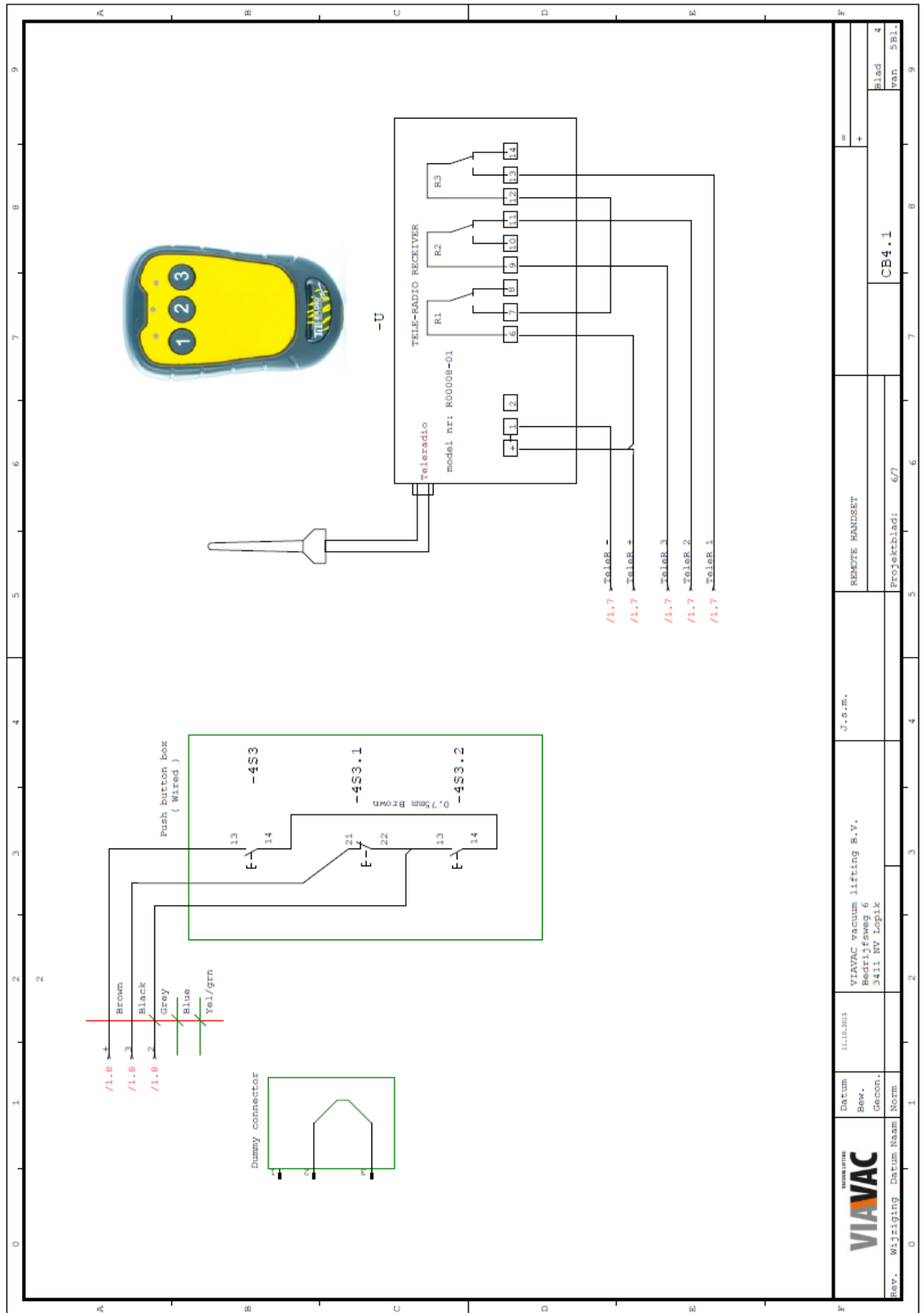

		Datum	11.10.2013	J.G.M.	REMOTE HANDSET	Blad	4
Rev.	Wijziging	Rev.	Gecon.	VIAVAC vacuum lifting B.V. Bedrijfsweg 6 3411 NV Lopik	Projectblad: 6/7	van	SBI.
				CB4.1			

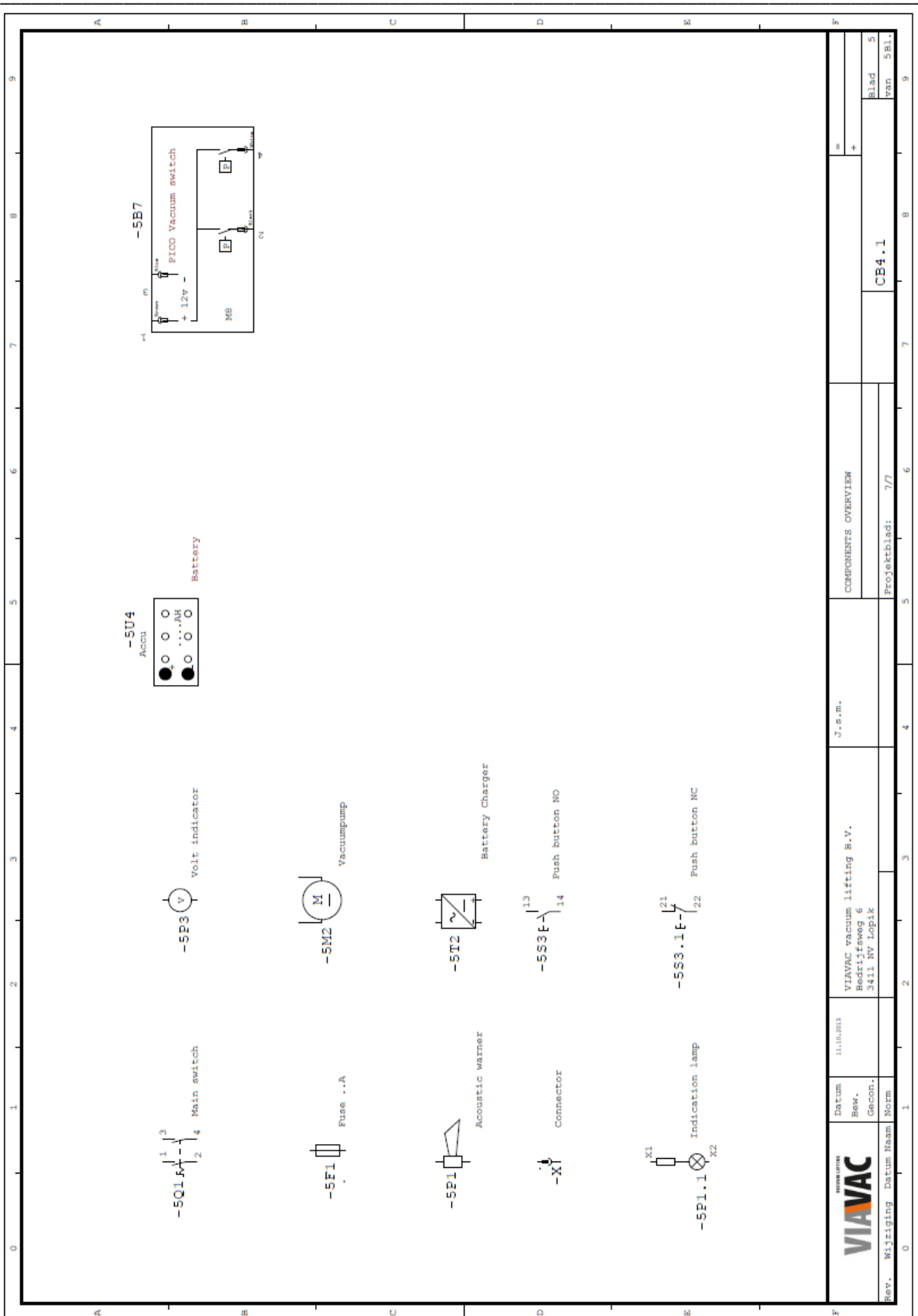

C 8 Vacuum diagram

CB4

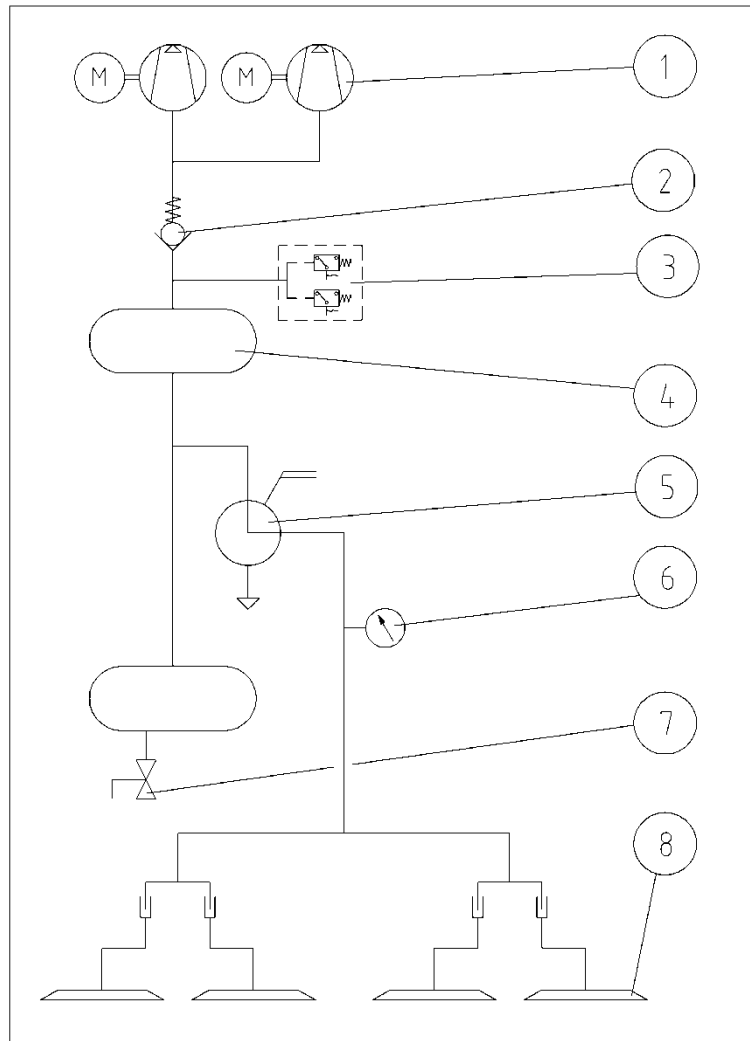

ITEM	DESCRIPTION
1	Vacuum pumps
2	Non return valve
3	Vacuum switch
4	Vacuum reserve tank
5	2 way ball valve
6	Vacuum indicator
7	Water drain valve
8	Suction pads

C 9 Digital vacuum switch

The digital vacuum switch is programmed in such a way that:

ALARM

When the vacuum level sinks below -0.60 bar, the acoustic alarm will sound and the red lamp will light up. and when the vacuum level increases above -0.60 bar, the acoustic alarm stops and the green lamp lights up.

VACUUM PUMP

When the vacuum level sinks below -0.65 bar, the vacuum pump starts running and will switch off after 10 seconds.

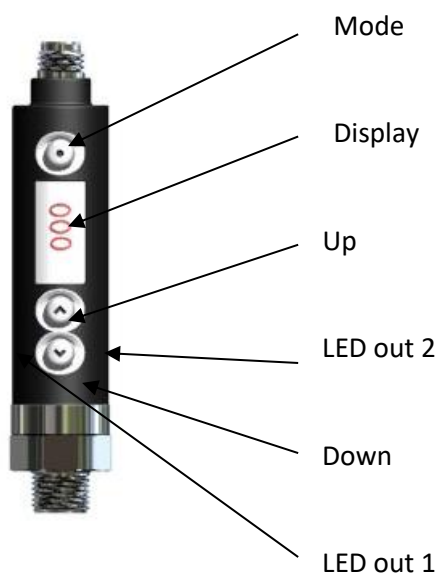

The settings of the digital vacuum switch are very exact and stable.

Normally it should not be necessary to adapt the settings during the lifetime of this device.

Should it be necessary to reset the values, contact VIAVAC for instructions.



C 10 Spare parts

Main spareparts are listed, these can also be found and ordered after registering at www.viavac.com/shop.

VIAVAC-CB4 vacuum unit						Art. no. 408500	
							
	A	B	C	D	E	F	G
1							
2							
3							







Pict.	Quan.	Description	Type	Art. no.	A
1-A	1	Battery	12V/50AH	33027	
1-B	1	Battery charger	12V/4A	33017	
1-C	1	LED fixture	22mm red	9054	
1-D	1	LED fixture	22mm green	9055	
1-E	1	LED lamp red	12V	9058	
1-F	2	LED lamp green	12V	9057	
1-G	2	LED adaptor		9056	
2-A	2	Vacuum pump	12V-1,5m3	23002	
2-B	1	Vacuum gauge set	Ø63mm, 1/4"	276502	
2-C	1	Volt indicator	Ø53mm, 12V	31010	
2-D	1	Acoustic alarm	Ø32mm, 5...16VDC – 96dB	162105	
2-E	1	PICO vacuum switch	4 pins	29001	
2-F	1	Connection cable	4 pins	29002	
2-G	1	Main switch	TM-1-8291	9034	
3-G	4	Relais	12V	21001	
3-B	2	Filter water separator	G"1/2"-1/2"	5001	
3-C	1	Cable box	CB4 & CB5	287403	
3-D	2	Button	Type B	9028	
3-E	2	Hand grip	G3/4", L=914	30805	
3-F	2	Non return valve	G3/8" I-I	2003	
3-G	4	Quick coupling "male-thread"	Male G1/2" NW 7.2	5072	

X = Recommended spare part

VIAVAC-CB4.1 vacuum unit prepared for remote control						Art. no. 257212	
							
	A	B	C	D	E	F	G
1							







Pict.	Quan.	Description	Type	Art. no.	A
1-A	1	Electro magnetic 3/2 valve	12VDC	177605	
1-B	1	Connector	female	155201	
1-C					
1-D					
1-E					
1-F					
1-G					

X = Recommended spare part

Adjustable suspension						Art. no. 290106	
							
	A	B	C	D	E	F	G
1							

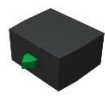

Pict.	Quan.	Description	Type	Art. no.	A
1-A	1	Suspension lock	CB	290105	X
1-B	1	Suspension frame	CB	290312	X
1-C	1	Suspension pin	Ø4 L=100	290202	X
1-D	1	Suspension nut	Ø45xM30, L=15	300102	X
1-E	2	Quick coupling	Ø6, L=40	226103	

X = Recommended spare part

CABLE REMOTE CONTROL						Art. no. 278201	
							
	A	B	C	D	E	F	G
1							









Pict.	Quan.	Description	Type	Art. no.	A
1-A	1	Connector	male	155101	
1-B	1	Connector switch NC	ZC2-BE102	9070	X
1-C	1	Connector switch NO	ZB2-BE101	9069	X
1-D	1	Rubber covered magnet	19mm	227102	
1-E	1	Green button	XAC-A413	9068	X
1-F	1	Red button	Male	9067	X
1-G					

X = Recommended spare part

RADIO REMOTE CONTROL						Art. no. 278206	
							
	A	B	C	D	E	F	G
1							





Pict.	Quan.	Description	Type	Art. no.	A
1-A	1	Remote control transmitter	3 buttons + code	279304	X
1-B	1	Remote control receiver	12-24Vdc 5 functions	152501	

X = Recommended spare part

MAIN TRAVERSE EXTENSION BEAM							Art. no. 408003
							
	A	B	C	D	E	F	G
1							







Pict.	Quan.	Description	Type	Art. no.	A
1-A	1	Spring cotter pin	3mm double	1007	
1-B	1	Securing pin with suspension	Ø16x120, Lc=400	408015	
1-C	2	2 ear hose clamp	Rnd 17 ... 20mm	12004	X
1-D	2	Hose clamp	ELVZ 11-17mm	1123	
1-E	2	Quick coupling	Female	5019	
1-F	2	Quick coupling	Male	5018	X
1-G	2	Hose 9,5x19,5	L=900 mm	12005	X

X = Recommended spare part

CROSS TRAVERSE WITH 2x2 SUCTION PAD SUSPENSION (SET)							Art. no. 408501
							
	A	B	C	D	E	F	G
1							





Pict.	Quan.	Description	Type	Art. no.	A
1-A	4	Spring cotter pin	3mm double	1007	
1-B	2	Securing pin with cable	Ø16x120, Lc=500	408014	
1-C	4	Suspension suction pad	40x40	402091	
1-D	4	Disc screw	M8x63	280208	
1-E					
1-F					
1-G					

X = Recommended spare part



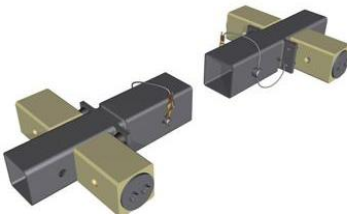



TILTING BEAM 90°						Art. no. 408006	
							
	A	B	C	D	E	F	G
1							

Pict.	Quan.	Description	Type	Art. no.	A
1-A	4	2 ear hoseclamp	Rnd 17 ... 20mm	12004	
1-B	4	Hose clamp	ELVZ 11-17mm	1123	
1-C	4	Quick coupling "female-hose"	Ø 9mm NW 7.2	5019	X
1-D	4	Quic coupling "male-thread"	G1/2" NW 7.2	5072	X
1-E	4	Fiber ring	G1/2"	5010	
1-F	4	Hose 9,5x19,5	L=650 mm	12005	
1-G					

X = Recommended spare part





CROSS TRAVERSE (SET)						Art. no. 408010	
							
	A	B	C	D	E	F	G
1							

Pict.	Quan.	Description	Type	Art. no.	A
1-A	4	Spring cotter	3mm double	1007	
1-B	2	Securing pin with cable	Ø16x120, Lc=400	408015	
1-C	8	Rubber buffer	KD 30x30	14005	X
1-D					
1-E					
1-F					
1-G					

SUCTION PAD WITH SUSPENSION 2X SP1-150X490-S2						ART. NO. 408033	
							
	A	B	C	D	E	F	G
1							



Pict.	Quan.	Description	Type	Art. no.	A
1-A	2	Spring cotter	3,5 double	1007	
1-B	2	Securing pin with cable	Ø16x120, Lc=400	408015	
1-C	2	Hose coupling	Ø 9 - G1/4	5002	
1-D	2	Seal	S2-1180	408028	x
1-E	2	Suction pad	SP1 150x490-S2	408024	x

X = Recommended spare part

SUCTION PADS WITH SUSPENSION SP1-90X550-S2						ART. NO. 408061	
							
	A	B	C	D	E	F	G
1							

Pict.	Quan.	Description	Type	Art. no.	A
1-A	2	Movable wall panel suspension	SPS4 - 90x90	38308	X
1-B	2	Suction pad SWL=60kg	SP1-90x550-S2	408020	X
1-C	2	Quick coupling female	Ø9; NW7.2	5019	
1-D	2	Hose	Ø9,5x19,5	12005	
1-E					
1-F					
1-G					

X = Recommended spare part





FALLING SAFETY DEVICE (SET) - FS4						Art. no. 408007	
							
	A	B	C	D	E	F	G
1							

Pict.	Quan.	Description	Type	Art. no.	A
1-A	2	Safety strap	SWL=500kg, L=3000	17009	x
1-B	2	Assembly pivoting clamp	50mm 1,3T	402086	

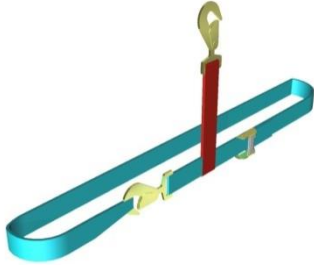
X = Recommended spare part

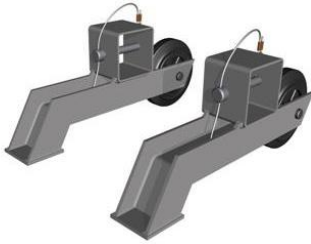



PANEL SECURING STRAP (WITH SLING) - 30/270/100		Art. no. 17003	
			

Panel securing strap (with hook) - 30/270/30		Art. no. 17004	
			

TRANSPORT WHEEL (SET)						Art. no. 408011	
							
	A	B	C	D	E	F	G
1							

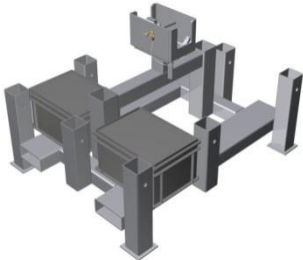
Pict.	Quan.	Description	Type	Art. no.	A
1-A	2	Spring cotter	3,55mm double	1007	
1-B	2	Securing pin with cable	Ø16x120, Lc=400	408015	
1-C	2	Wheel	Ø160x40	39003	
1-D					

X = Recommended spare part

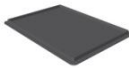
TRANSPORT FRAME						Art. no. 408012	
							
	A	B	C	D	E	F	G
1							

Pict.	Quan.	Description	Type	Art. no.	A
1-A	1	Spring cotter	3,5mm double	1007	
1-B	1	Securing pin bended without loop	Ø16x210, Lc=570	408013	
1-C	2	Box	400x300x220	294117	
1-D	2	Cover for box	400x300	32005	
1-E					

X = Recommended spare part

SP1			Suction pad 1					
<p style="text-align: center;"><u>Aluminum with groove 15x15 for exchangeable seal</u></p>								
type			L seal	F _{hor} (kg)	F _{ver} (kg)	art. no.	remark	
pad	W x L	seal						
SP1	70x570	S1	1180	80	40	402092	A	
		S2					408025	B
SP1	90x550	S1	1180	120	60	402087	A	
		S2					408020	B
		S3					-	C
		S6					-	E
SP1	110x530	S1	1180	150	75	402502	A	
		S2					264116	B
		S3					-	C
		S6					-	E
SP1	150x490	S1	1180	200	100	408023	A	
		S2					408024	B
		S4					-	D



F_{hor} = Horizontal lifting capacity at 0,6 bar vacuum level with 2 fold safety margin.

F_{ver} = Vertical lifting capacity at 0,6 bar vacuum level with 2 fold safety margin.

Remark



- A Sealing ring compensates up to 5mm profiling
- B Sealing ring compensates up to 3mm profiling
- C Sealing ring for roof tray's type 106, 153 & 158

- D Sealing ring for roof tray's type 135
- E Sealing ring for roof tray's type 106 SAB

S1	Sealing ring 1 (for sandwich roof panels)		
 15x36			
type	L _{seal}	art. no.	remark
S1-680	680	400117	A
S1-980	980	402033	A
S1-1180	1180	408027	A



Remark

A Sealing ring for suction pad groove 15x15mm, compensates up to 5mm profiling.

S2	Sealing ring 2 (for sandwich wall panels)		
 15x32			
type	L _{seal}	art. no.	remark
S2-980	980	402041	A
S2-1180	1180	408028	A
S2-1470	1470	402034	A

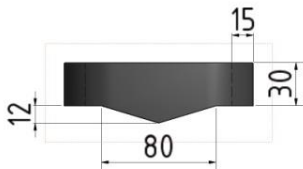

Remark

A Sealing ring for suction pad groove 15x15mm, compensates up to 3mm profiling.

S3	Sealing ring 3 (for roof tray's)		
			
type	L seal	art. no.	remark
S3-980	980	402500	A
S3-1180	1180	402501	A

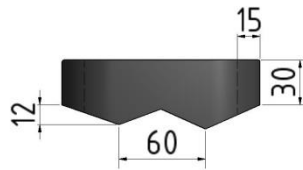

Remark

A Sealing ring for suction pad groove 15x15mm, for roof tray's type 106, 153 & 158.

S4	Sealing ring 4 (for roof tray's)		
			
type	L seal	art. no.	remark
S4-980	980	402503	A
S4-1180	1180	402504	A

Remark

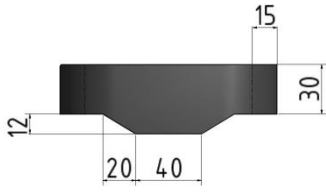
A Sealing ring for suction pad groove 15x15mm, for roof tray's type 135

S6	Sealing ring 6 (for roof tray's)		
			
type	L seal	art. no.	remark
S6-980	980	402505	A
S6-1180	1180	402506	A

Remark

A SAB type 106 (new)

C 12 Erradata

Date	Rev.	Description	Sect.	Name
01-01-2010	-	Completely new written	-	AdG
20-02-2010	Added	If the load has a protective film, it must first be removed before the suction pad is placed on the load.	B3	AdG
01-07-2010	Altered	8-27 Wind speeds	C10	AdG
	Added	8-28 Wind bursts		
01-10-2013	Added	Inspection and maintenance topics	C4	AdG
	Added	CB 4.1	B3	
	Added	Cable remote control and radio remote control	B3	
	Added	Max. wind speeds	B6	
	Added	Ajustments when use at altitudes above 1200mtr	B3	
	Added	Reduced lifting capacity at altitudes above 500 meter	B3	
	Added	Configurations R8000/2600-K8 & R9800/2600-K8	B6	
	Added	Configurations R15200/6200-K8K16 & R17000/6200-98-K8K16	B6	
01-03-2014	Added	Configuration R4400-K4, R6200-K4	B6	AdG
01-06-2015	Added	Type 4.1	A1	AdG
01-07-2016	Modified	CB4 electric diagram modified	C7	IG
	Added	Electric diagram for CB4.1	C7	
01-07-2017	Modified	Low voltage directive.	A2	IG
		EMC directive.	A2	
		Components part numbers changed of configurations.	B6	
		Components part numbers changed of configurations.	B7	
		Electric diagram changed.	C7	
		Spare parts part number changed, new spare parts added.	C10	