



EW100

Mobile Excavators > 6 t



Quickly on the go with the EW100

The 10-ton mobile excavator EW100 wins over with a power output, low fuel consumption and particularly user-friendly features. The minimized fuel consumption – with savings of up to 20 percent – is achieved through the new ECO operating mode, which allows for efficient work by reducing the rpm's and by adapting the pump: a plus for the environment and the wallet. The mobile excavator EW100 is particularly operator-friendly thanks to a drive pedal – for both road travel as well as working operation.

- With 40km/h, it is the fastest mobile excavator in its class
- 15% more power output with up to 20% less fuel consumption
- Equipped with a tier IVi engine
- Modern jog dial system, known in the automotive industry: The menu is intuitively operated via a rotary push button
- Maximum connection options with up to 5 auxiliary control circuits, of which 3 are individually adjustable



Technical specifications

EW100 with mono-boom

Operating data

Shipping weight min.	9,590 kg
Operating weight min.	10,035 kg
Biting force max. (ISO 6015)	25.8 kN
Breakaway force max. (ISO 6015)	38.9 daN
Digging depth min.	4,000 mm
Dumping height max.	5,350 mm
Digging radius min.	7,540 mm
L x W x H	7,255 x 2,450 x 2,980 mm

Engine / Motor

Engine / Motor manufacturer	Perkins
Engine / Motor type	854
Engine / Motor	Liquid-cooled, 4-cylinder turbo diesel engine
Displacement	3,300 cm ³
RPM / speed	2,400 rpm
Engine performance according to ISO	86 kW
Battery	100 Ah

Hydraulic system

Duty pump	1-pump Load Sensing
Flow rate	180 l/min
Operating pressure for driving hydraulics	440 bar
Hydraulic oil tank	120 l

Wheel set

Axles Front axle	Oscillating steering axle
Axles Rear axle	Rigid steering axle
Tires Standard	Dual tires 8.25/20
Turning radius	5,570 mm
Track width	1,942 mm



Ground clearance	361 mm
Travel speed 20 km/h version, max.	20 km/h
Travel speed 40 km/h version, max.	40 km/h

Dozer Blade

Width	2,465 mm
Height	500 mm
Stroke	498 mm
Stroke	132 mm

Sound level

Sound level (LwA)	101 dB(A)
-------------------	-----------

EW100 with triple-boom

Operating data

Shipping weight min.	9,590 kg
Operating weight min.	10,035 kg
Biting force max. (ISO 6015)	40.34 kN
Breakaway force max. (ISO 6015)	5,060 daN
Digging depth min.	3,950 mm
Dumping height max.	6,205 mm
Digging radius min.	7,815 mm
L x W x H	6,656 x 2,450 x 2,980 mm

Engine / Motor

Engine / Motor manufacturer	Perkins
Engine / Motor type	854
Engine / Motor	Liquid-cooled, 4-cylinder turbo diesel engine
Displacement	3,300 cm ³
RPM / speed	2,400 rpm
Engine performance according to ISO	86 kW
Battery	100 Ah



Hydraulic system

Duty pump	1-pump Load Sensing
Flow rate	180 l/min
Operating pressure for driving hydraulics	440 bar
Hydraulic oil tank	120 l

Wheel set

Axles Front axle	Oscillating steering axle
Axles Rear axle	Rigid steering axle
Tires Standard	Dual tires 8.25/20
Turning radius	5,570 mm
Track width	1,942 mm
Ground clearance	361 mm
Travel speed 20 km/h version, max.	20 km/h
Travel speed 40 km/h version, max.	40 km/h

Dozer Blade

Width	2,465 mm
Height	500 mm
Stroke max., above subgrade	498 mm
Stroke max., below subgrade	132 mm

Sound level

Sound level (LwA) according to 2000/14/EC	101 dB(A)
-------------------------------------------	-----------



Dimensions

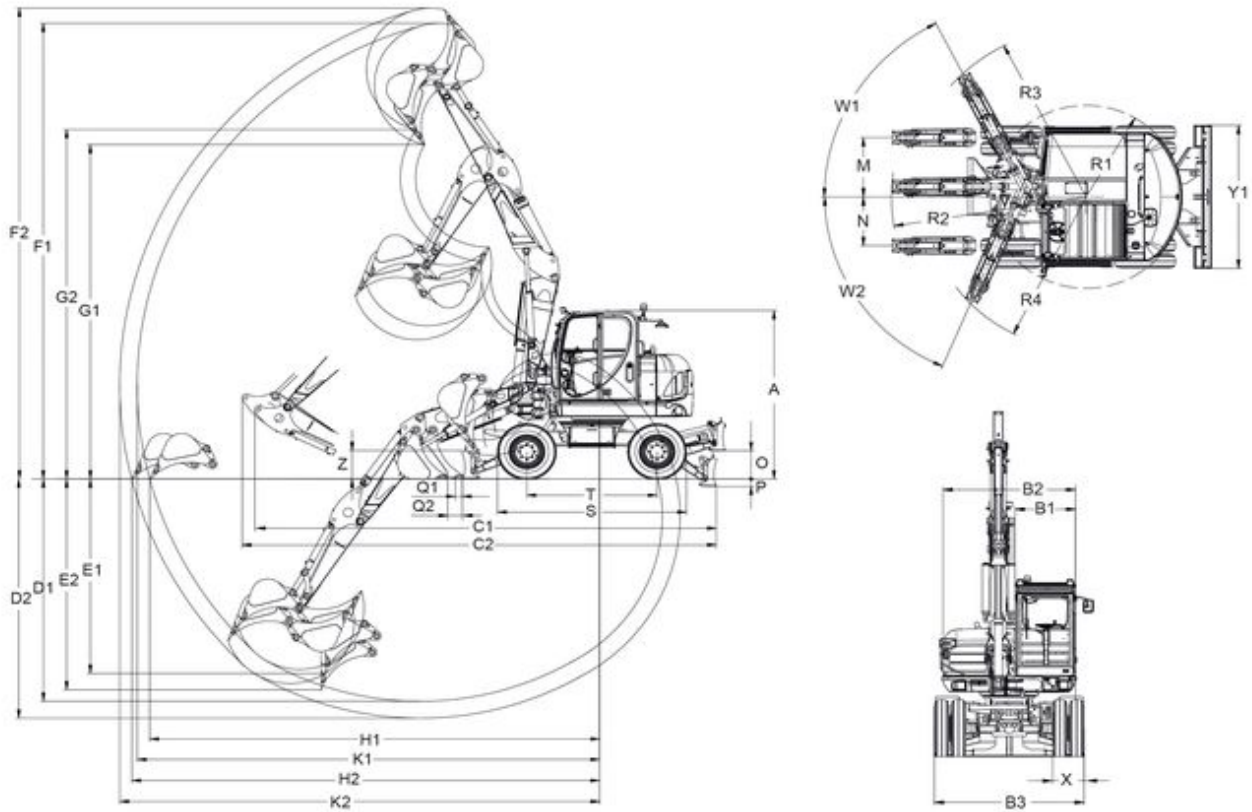

A	Height	2,980 mm
B1	Width Cabin	990 mm
B2	Width Revolving superstructure	2,174 mm
B3	Width Traversing gear	2,450 mm
C1	Transport length VA, short ds	6,656 mm
C2	Transport length VA, long ds	6,886 mm
D1	Digging depth max., VA, short ds	3,950 mm
D2	Digging depth max., VA, long ds	4,250 mm
E1	Insertion depth max., vertical , VA, short ds	3,450 mm
E2	Insertion depth max., vertical, VA, long ds	3,750 mm
F1	Insertion height max., VA, short ds	8,090 mm
F2	Insertion height max., VA, long ds	8,355 mm
G1	Dumping height max., VA, short ds	5,935 mm



G2	Dumping height max., VA, long ds	6,205 mm
H1	Range max. on the bottom, VA, short ds	7,605 mm
H2	Range max. on the bottom, VA, long ds	7,905 mm
K1	Digging radius max., VA, short ds	7,815 mm
K2	Digging radius max., VA, long ds	8,105 mm
O	Lift height max., dozer blade above subgrade	504 mm
P	Scraping depth max., dozer blade below subgrade	132 mm
Q1	Distance Bucket dozer blade (VA, short ds)	120 mm
Q2	Distance Bucket dozer blade (VA, long ds)	165 mm
R1	Rear swivel radius min.	1,575 mm
R2	Boom slewing radius Middle; triple-boom	3,190 mm
R3	Boom slewing radius Right; triple-boom	2,930 mm
R4	Boom slewing radius Left; triple-boom	2,640 mm
S	Length Total traveling gear	3,193 mm
T	Length Traveling gear, Turas guide wheel	2,200 mm
X	Width Dual tires	514 mm
X	Width Balloon tires	530 mm
Y1	Width Dozer blade	2,465 mm
Z	Height Dozer blade	507 mm

VA...triple boom ds...dipperstick

Please note

that product availability can vary from country to country. It is possible that information / products may not be available in your country. More detailed information on engine power can be found in the operator's manual; the stated power may vary due to specific operating conditions.

Subject to alterations and errors excepted. Applicable also to illustrations.

Copyright © 2014 Wacker Neuson SE.