

# VIAVAC GBX2

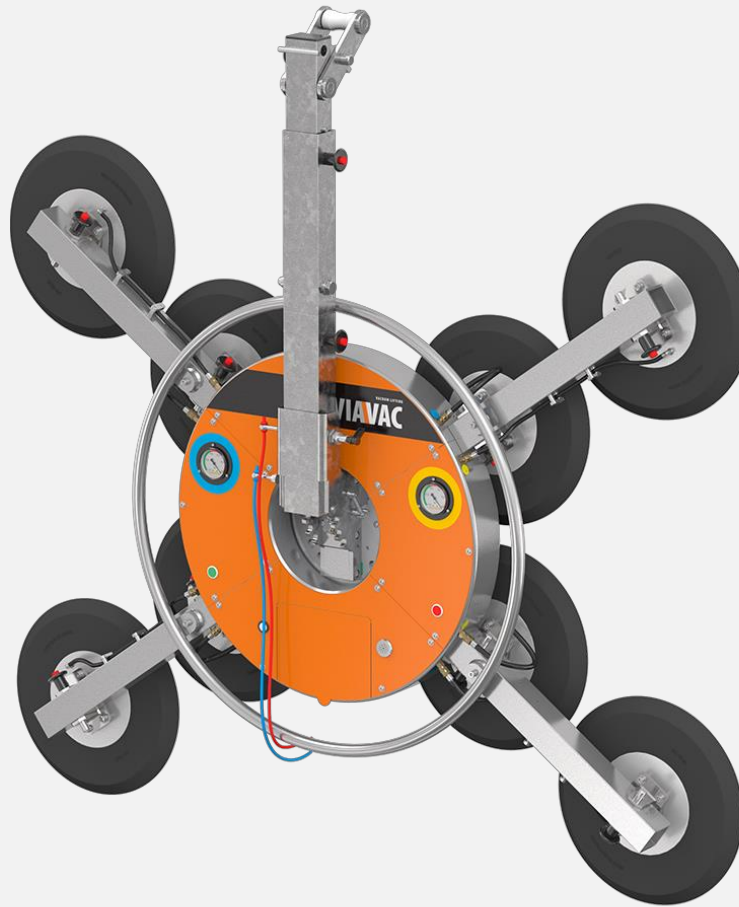

Modular in 6  
configurations  
for glass.

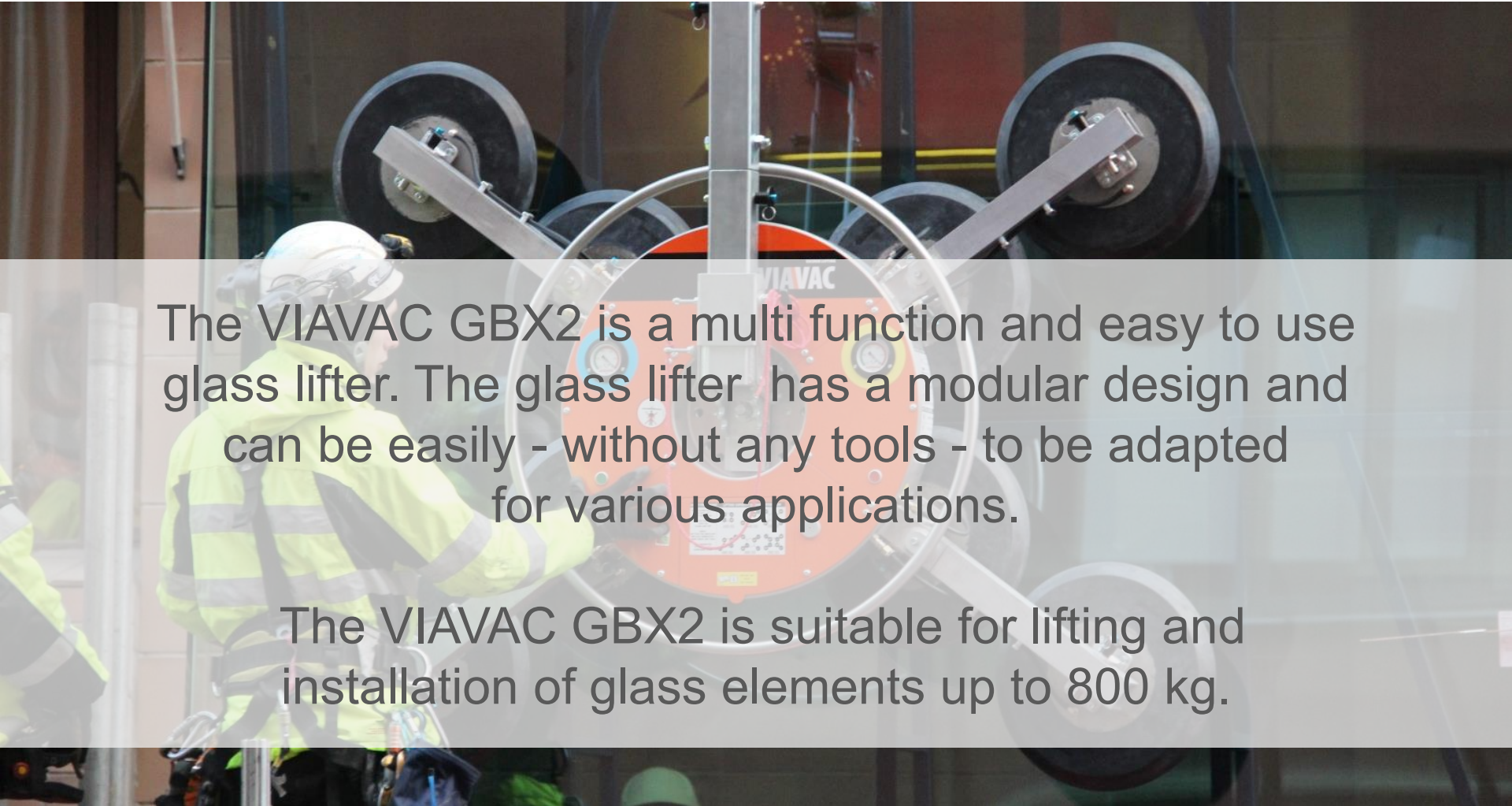

The VIAVAC GBX2 is a multi function and easy to use glass lifter. The glass lifter has a modular design and can be easily - without any tools - to be adapted for various applications.

The VIAVAC GBX2 is suitable for lifting and installation of glass elements up to 800 kg.

# Advantages VIAVAC GBX2

---

- ✓ One device which can be built-up in six different configurations.
- ✓ Two independent operating vacuum circuits. An additional fall safety device is not required.
- ✓ 360° rotatable suction pads and 90° tilting device with adjustable lock each 15°.
- ✓ Robust aluminum construction and compact design.
- ✓ Complies with all EU safety regulations and all Health and Safety requirements.

# VIAVAC GBX2

---



The great usability of the VIAVAC GBX2 makes it particularly suitable for installations with varying conditions.

# One glass lifter - six configurations



400 kg



400 kg



400 kg



600 kg



600 kg



800 kg

# VIAVAC GBX2 - remote control

For difficult accessible places the VIAVAC GBX is (optionally) available with a safety radio remote control for vacuum release.



# VIAVAC GBX2 - Counter Balancer

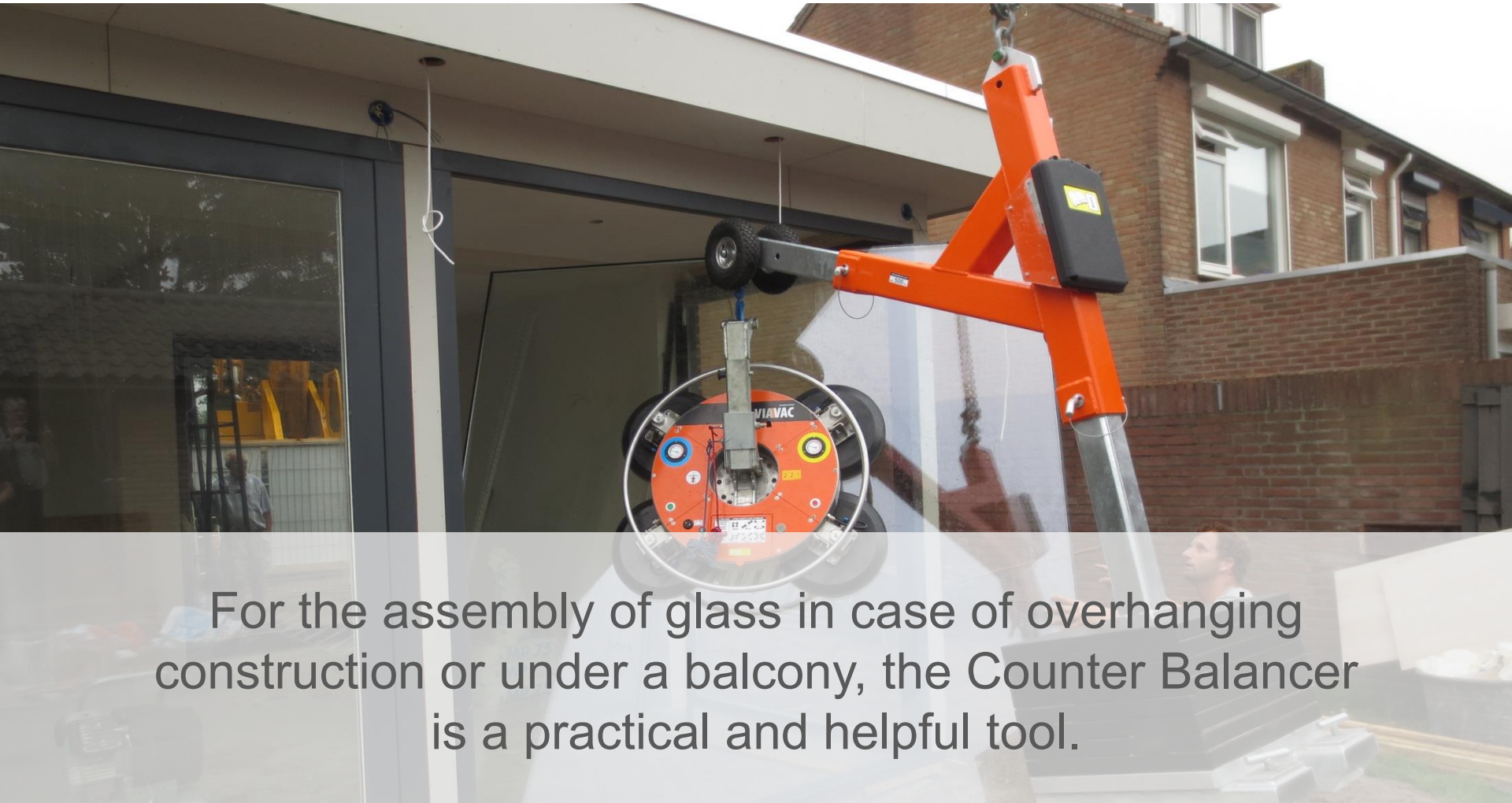

For the assembly of glass in case of overhanging construction or under a balcony, the Counter Balancer is a practical and helpful tool.

# GBX2 - practical cases





# GBX2 - practical cases



# Options



Robust, closable transport box for safely transporting and storing of the glass lifter.



Radio remote control equipped with safety code to protect against accidental operation.



Extended suspension for windows with construction frame.



Suction cups available in various sizes; 300 mm, 350 mm and 400 mm.



Counter balancer for glass installation in situations with an overhanging construction or balconies.



This lifting arm reduces the lifting height. Favourable in cases where there is limited installation height.

# Specifications

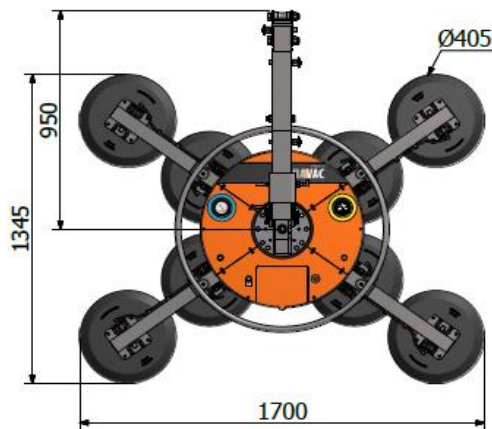

## **VIAVAC GBX2**

Lifting capacity: max. 800 kg

Own weight: 100kg

### **Battery:**

12V/10Ah. Sufficient for lifting ca. 50 elements

### **Functions:**

Suction pads 360° rotatable and can be locked in 8 different positions.

90° tilting and can be locked in 6 different positions.

### **Vacuum system:**

Two independent working vacuum circuits. No additional falling safety straps needed

### **Safety:**

- Two independent working vacuum circuits
- Lifting capacity with a two-fold safety factor
- Alarm signal in case of a too low level of vacuum.
- Vacuum level indicators with vacuum gauge and visual red/green signal.

### **Norm:**

The GBX2 complies with all EU safety regulations and requirements for vacuum lifting devices according the EN 13155.

## **VIAVAC vacuum lifting bv**

Bedrijfsweg 6  
3411 NV Lopik  
The Netherlands  
T: +31 (0)348 - 449 660  
E: [info@viavac.com](mailto:info@viavac.com)

[www.viavac.com](http://www.viavac.com)